

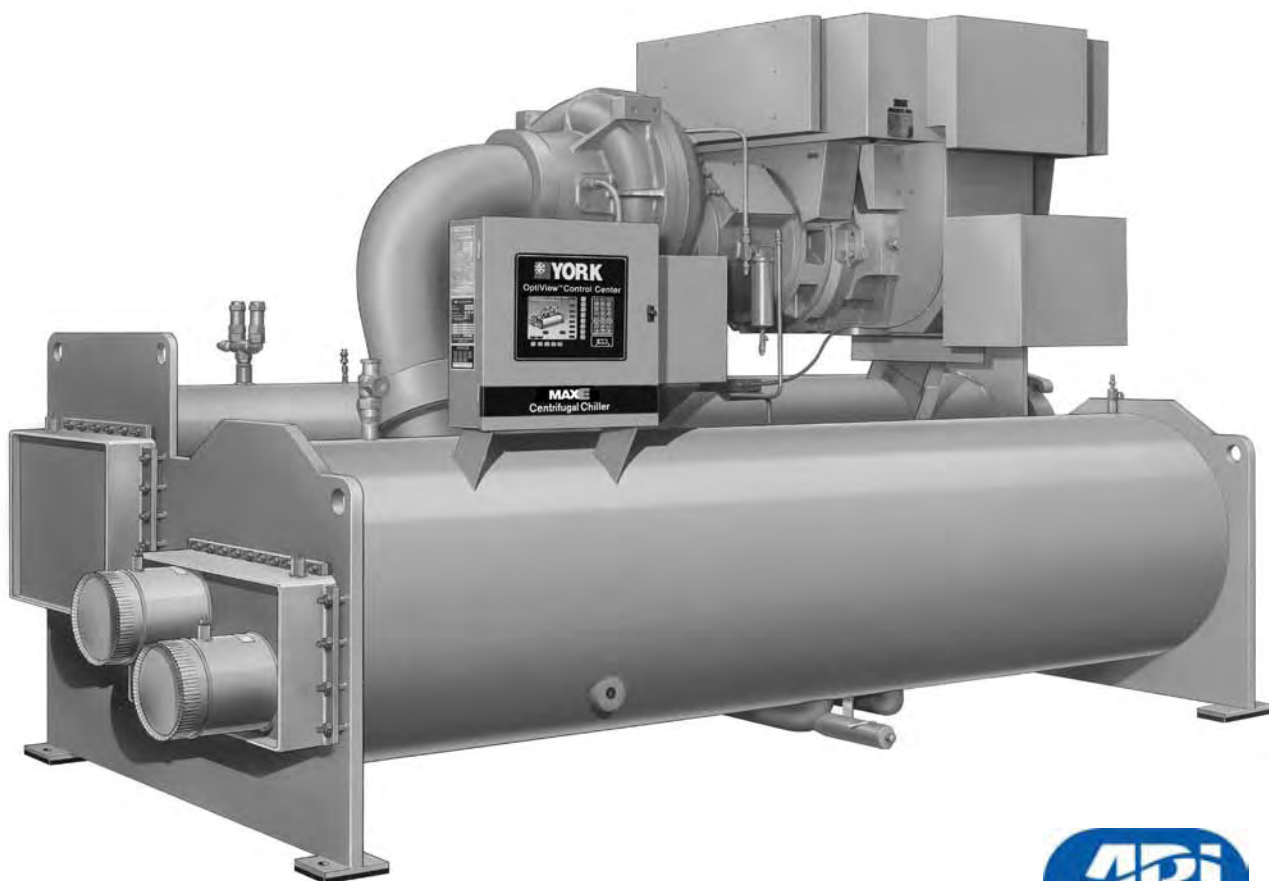

MAXE™

Centrifugal Liquid Chillers

Design Level G



**250 THROUGH 3000 TONS
(879 through 8440 kW)
Utilizing HFC-134a**



Rated in Accordance
with the latest edition of ARI
STANDARD 550/590

TABLE OF CONTENTS

Introduction	3
Ratings.....	4
OptiView Control Center	5
Mechanical Specifications	13
Accessories and Modifications	18
Application Data.....	20
Dimensions (Ft. - In.) – P & Q Compressor Units.....	35
Dimensions (Ft. - In.) – H Compressor Units.....	36
Dimensions (Ft. - In.) – K Compressor Units	37
Dimensions (Ft. - In.) – Nozzle Arrangements:	
Evaporators – Compact Water Boxes	38
Condensers – Compact Water Boxes	41
Evaporators – Marine Water Boxes	43
Condensers – Marine Water Boxes	45
Approximate Unit Weights (Lbs.)	47
Marine Water Box Weight Additions (Lbs.)	48
Dimensions (mm) P & Q Compressor Units	49
Dimensions (mm) H Compressor Units	50
Dimensions (mm) K Compressor Units	51
Dimensions (mm) Nozzle Arrangements:	
Evaporators – Compact Water Boxes	52
Condensers – Compact Water Boxes	55
Evaporators – Marine Water Boxes	57
Condensers – Marine Water Boxes.....	59
Approximate Unit Weights (Kg).....	61
Marine Water Box Weight Additions (Kg).....	62
Guide Specifications	63
SI Metric Conversion	69

NOMENCLATURE

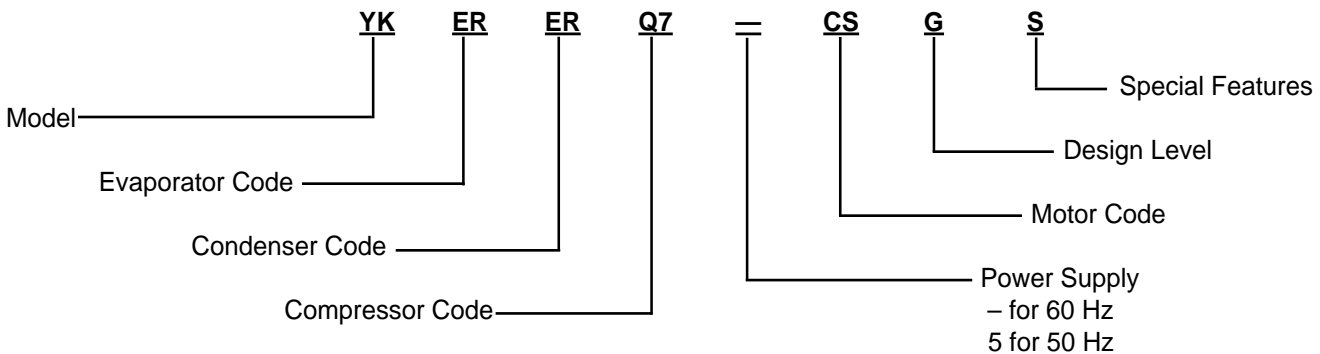

Introduction

The YORK MaxE™ YK Chillers offer a complete combination of features for total owner satisfaction.

MATCHED COMPONENTS MAXIMIZE EFFICIENCY

Actual chiller efficiency cannot be determined by analyzing the theoretical efficiency of any one chiller component. It requires a specific combination of heat exchanger, compressor, and motor performance to achieve the lowest system kW/ton. YORK MaxE chiller technology matches chiller system components to provide maximum chiller efficiency under actual – not just theoretical – operating conditions.

REAL-WORLD ENERGY PERFORMANCE

YORK pioneered the term “Real-World Energy” to illustrate the energy-saving potential of focusing on chiller performance during off-design conditions. Off-design is not only part load, but full load operation as well, with reduced entering condenser water temperatures (ECWTs). This is where chillers operate 99% of the time, and where operating costs add up.

The YK MaxE chillers are the only chillers designed to operate on a continuous basis with cold ECWT and full condenser flow at all load points, taking full advantage of Real-World conditions. This type of operation benefits the cooling tower as well; reducing cycling of the fan motor and ensuring good coverage of the cooling fill.

YORK MaxE chillers offer the most efficient Real-World operation of any chiller, meaning lower operating costs and an excellent return on your chiller investment.

OPEN-DRIVE DESIGN

Hermetic-motor burnout can cause catastrophic damage to a chiller. The entire chiller must be cleaned, and the refrigerant replaced. YORK MaxE centrifugal chillers eliminate this risk by utilizing air-cooled motors. Refrigerant never comes in contact with the motor, preventing contamination of the rest of the chiller.

Insurance companies that offer policies on large air conditioning equipment often consider air-cooled motors a significant advantage over hermetic refrigerant-cooled units.

HIGH-EFFICIENCY HEAT EXCHANGERS

MaxE chiller heat exchangers offer the latest technology in heat transfer surface design to give you maximum efficiency and compact design. Waterside and refrigerant-side design enhancements minimize both energy consumption and tube fouling.

SINGLE-STAGE COMPRESSOR DESIGN AND EFFICIENCY PROVEN IN THE MOST DEMANDING APPLICATIONS

Designed to be the most reliable chillers we've ever made, YORK YK MaxE centrifugal chillers incorporate single-stage compressor design. With fewer

moving parts and straightforward, efficient engineering, YORK single-stage compressors have proven durability records in hospitals, chemical plants, gas processing plants, the U.S. Navy, and in other applications where minimal downtime is a crucial concern.

In thousands of installations worldwide, YORK single-stage compressors are working to reduce energy costs. High strength aluminum-alloy compressor impellers feature backward-curved vanes for high efficiency. Airfoil shaped pre-rotation vanes minimize flow disruption for the most efficient part load performance. Precisely positioned and tightly fitted, they allow the compressor to unload smoothly from 100% to minimum load for excellent operation in air conditioning applications.

PRECISION CONTROL OF COMPRESSOR OIL PRESSURE

Utilizing our expertise in variable speed drive technology and applications, YORK has moved beyond the fixed head and bypass approach of oil pressure control. The old approach only assures oil pressure at the outlet of the pump rather than at the compressor, and allows no adjustment during chiller operation. The YK MaxE chillers feature a variable speed drive oil pump, monitoring and providing the right amount of oil flow to the compressor on a continuous basis. This design also provides sophisticated electronic monitoring and protection of the oil pump electrical supply, ensuring long life and reliable operation of the oil pump motor. Variable speed drive technology reduces oil pump power consumption, running only at the speed required, rather than at full head with a pressure regulating bypass valve.

FACTORY PACKAGING REDUCES FIELD LABOR COSTS

YORK MaxE centrifugal chillers are designed to keep installation costs low. Where installation access is not a problem, the unit can be shipped completely packaged, requiring minimal piping and wiring to complete the installation.

For those units utilizing Variable Speed Drive or a factory-installed Solid State Starter, the three power leads provide all power to the chiller and its auxiliaries.

TAKE ADVANTAGE OF COLDER COOLING TOWER WATER TEMPERATURES

YORK MaxE centrifugal chillers have been designed to take full advantage of colder cooling tower water temperatures, which are naturally available during most operating hours. Considerable energy savings are available by letting tower water temperature drop, rather than artificially holding it above 75°F (23.9°C), especially at low load, as some chillers require.

U.L. ACCEPTANCE – YOUR ASSURANCE OF RELIABILITY

YORK MaxE centrifugal chillers are approved for listing by Underwriter's Laboratories for the United States and Canada. Recognition of safety and reliability is your assurance of trouble-free performance in day-to-day building operation.

Ratings



Rated in accordance with the latest issuance of ARI Standard 550/590.

through each YORK sales office. These ratings can be tailored to specific job requirements, and are part of the ARI Certification Program.

ARI CERTIFICATION PROGRAM

The performance of YORK MAXE chillers has been certified to the Air Conditioning and Refrigeration Institute (ARI) as complying with the certification sections of the latest issue of ARI Standard 550/590. Under this Certification Program, chillers are regularly tested in strict compliance with this Standard. This provides an independent, third-party verification of chiller performance.

COMPUTERIZED PERFORMANCE RATINGS

Each chiller is custom-matched to meet the individual building load and energy requirements. A large number of standard heat exchangers and pass arrangements are available to provide the best possible match.

It is not practical to provide tabulated performance for each combination, as the energy requirements at both full and part load vary significantly with each heat exchanger and pass arrangement. Computerized ratings are available

OFF-DESIGN PERFORMANCE

Since the vast majority of its operating hours are spent at off-design conditions, a chiller should be chosen not only to meet the full load design, but also for its ability to perform efficiently at lower loads and lower tower water temperatures. It is not uncommon for chillers with the same full load kW/ton to have an operating cost difference of over 10% due to part-load operation.

Part load information can be easily and accurately generated by use of the computer. And because it is so important to an owner's operating budget, this information has now been standardized within the ARI Certification Program in the form of an Integrated Part Load Value (IPLV), and Non-Standard Part Load Value (NPLV).

The IPLV / NPLV formulas from ARI Standard 550/590 much more closely track actual chiller operations, and provide a more accurate indication of chiller performance than the previous IPLV/APLV formula. A more detailed analysis must take into account actual building load profiles, and local weather data. Part load performance data should be obtained for each job using its own design criteria.

OptiView Control Center



YK OPTIVIEW CONTROL CENTER

The YORK OptiView Control Center, furnished as standard on each chiller, provides the ultimate in efficiency, monitoring, data recording, chiller protection and operating ease. The Control Center is a factory-mounted, wired and tested state-of-the-art microprocessor based control system for R134a centrifugal chillers. The panel is configured with a 10.4-in. diagonal color Liquid Crystal Display (LCD) surrounded by “soft” keys, which are redefined with one keystroke based on the screen displayed at that time. This revolutionary development makes chiller operation quicker and easier than ever before. Instead of requiring keystroke after keystroke to hunt for information on a small monochrome LCD screen, a single button reveals a wide array of information on a large, full-color illustration of the appropriate component, which makes information easier to interpret. This is all mounted in the middle of a keypad interface and installed in a locked enclosure.

The LCD display allows graphic animated display of the chiller, chiller sub-systems and system parameters; this allows the presentation of several operating parameters at once. In addition, the operator may view a graphical representation of the historical operation of the chiller as well as the present operation. A Status Bar is displayed at all times on all screens. It contains the System - Status Line and Details Line, the Control Source, Access Level, Time and Date.

During prelube and coast-down, the system status will include a countdown timer indicating the time remaining. The control panel is compatible with the YORK Solid State Starter (optional); YORK Variable Speed Drive (VSD) (Optional); Electro-mechanical (E-M) starter or any customer supplied E-M starter that complies with the YORK R-1132 standard. The locations of various chiller parameters are

clearly marked and instructions for specific operations are provided for on many of the screens. The panel verbiage is available in eight languages as standard and can be changed on the fly without having to turn off the chiller. Data can be displayed in either English or Metric units plus keypad entry of setpoints to 0.1 increments.

Security access is provided to prevent unauthorized changes of setpoints. This is accomplished with three different levels of access and passwords for each level. There are certain screens, displayed values, programmable setpoints and manual controls not shown that are for servicing the chiller. They are only displayed when logged in at service access level. Included in this is the Advanced Diagnostics and troubleshooting information for the chiller and the panel.

The panel is fused through a 1-1/2 or 2 KVA transformer in the compressor motor starter to provide individual over-current protected power for all controls. Numbered terminal strips for wiring such as Remote Start/Stop, Flow Switches, Chilled Water Pump and Local or Remote Cycling devices are provided. The Panel also provides field interlocks that indicate the chiller status. These contacts include a Remote Mode Ready-to-Start, a Cycling Shutdown, a Safety Shutdown and a chiller Run contact. Pressure transducers sense system pressures and thermistors sense system temperatures. The output of each transducer is a DC voltage that is analogous to the pressure input. The output of each thermistor is a DC voltage that is analogous to the temperature it is sensing.

Setpoints can be changed from a remote location via 0-10VDC, 4-20mA, contact closures or through serial communications. The adjustable remote reset range [up to 20°F (11.1°C)] provides flexible, efficient use of remote signal

OptiView Control Center (continued)

depending on reset needs. Serial data interface to the Building Automation System (BAS) is through the optional Microgateway, which can be mounted inside the Control Center.

This printed circuit board requests the required data from the Microboard and makes it available for the Johnson Controls Metasys® network. This optional board is available through the Johnson Controls Building Efficiency group. The operating program is stored in non-volatile memory (EPROM) to eliminate chiller failure due to AC power failure/battery discharge. Programmed setpoints are retained in lithium battery-backed RTC memory for 11 years minimum.

Smart Freeze Point Protection will run the chiller at 36°F (2.2°C) leaving chilled water temperature, and not permit nuisance trips on Low Water Temperature. The sophisticated program and sensor will monitor the chiller water temperature to prevent freeze up. Every programmable point has a pop-up screen with the allowable ranges, so that the chiller can not be programmed to operate outside of its design limits.

When the power is applied to the chiller, the **HOME** screen is displayed. This screen displays a visual representation of the chiller and a collection of data detailing important operations and parameters. When the chiller is running the flow of chilled liquid is animated by the alternating shades of color moving in and out of the pipe nozzles. The primary values that need to be monitored and controlled are shown on this screen. They are as follows:

Display Only

- Chilled Liquid Temperature – Leaving
- Chilled Liquid Temperature – Return
- Condenser Liquid Temperature – Return
- Condenser Liquid Temperature – Leaving
- Motor Run (LED)
- % Full Load Amps
- Operating Hours
- Input Power (kW) (VSD Only)

With the “soft” keys the operator is only one touch away from the 8 main screens that allows access to the major information and components of the chiller. The 8 screens are the **SYSTEM, EVAPORATOR, CONDENSER, COMPRESSOR, OIL SUMP, MOTOR, SETPOINTS** and the **HISTORY**. Also on the Home screen is the ability to **Log IN, Log Out** and **Print**. Log In and Log Out is the means by which different security levels are accessed.

The **SYSTEM** screen gives a general overview of common

chiller parameters for both shells. This is an end view of the chiller with a 3D cutaway of both the shells. From this screen you can view the following.

Display Only

- Discharge Temperature
- Chilled Liquid Temperature – Leaving
- Chilled Liquid Temperature – Return
- Chilled Liquid Temperature – Setpoint
- Evaporator Pressure
- Evaporator Saturation Temperature
- Condenser Liquid Temperature – Leaving
- Condenser Liquid Temperature – Return
- Condenser Pressure
- Condenser Saturation Temperature
- Oil Sump Temperature
- Oil Pressure
- % Full Load Amps
- Current Limit

The **EVAPORATOR** screen displays a cutaway view of the chiller evaporator. All setpoints relating to the evaporator side of the chiller are maintained on this screen. Animation of the evaporation process indicates whether the chiller is presently in RUN condition (bubbling) and liquid flow in the pipes is indicated by alternating shades of color moving in and out of the pipes. Adjustable limits on the low water temperature setpoints allow the chiller to cycle on and off for greater efficiency and less chiller cycling. The chiller cycles off when the leaving chilled water temperature is below setpoint and is adjustable from 1°F (.55°C) below to a minimum of 36°F (2.2°C). Restart is adjustable from setpoint up to a max of 80°F (44.4°C). The Panel will check for flow to avoid freeze up of the tubes. If flow is interrupted shutdown will occur after a minimum of two seconds. From this screen you can perform the following.

Display Only

- Chilled Liquid Flow Switch (Open/Closed)
- Chilled Liquid Pump (Run/Stop)
- Evaporator Pressure
- Evaporator Saturation Temperature
- Return Chilled Liquid Temperature
- Leaving Chilled Liquid Temperature
- Evaporator Refrigerant Temperature
- Small Temperature Difference
- Leaving Chilled Liquid Temperature Setpoints – Control Setpoint
- Leaving Chilled Liquid Temperature Setpoints –

Shutdown

- Leaving Chilled Liquid Temperature Setpoints – Restart

Programmable

- Local Leaving Chilled Liquid Temperature – Range
- Local Leaving Chilled Liquid Temperature – Setpoint
- Leaving Chilled Liquid Temperature Cycling Offset – Shutdown
- Leaving Chilled Liquid Temperature Cycling Offset – Restart

The **CONDENSER** screen displays a cutaway view of the chiller condenser. The liquid flow is animated to indicate flow through the condenser. All setpoints relating to the condenser side of the chiller are maintained on this screen. With the proper access level, this screen also serves as a gateway to controlling the Refrigerant Level. From this screen you can view the following:

Display Only

- Leaving Condenser Liquid Temperature
- Return Condenser Liquid Temperature
- Condenser Pressure
- Condenser Saturation Temperature
- Small Temperature Difference
- Drop Leg Refrigerant Temperature
- Sub-Cooling Temperature
- High Pressure Switch (Open/Closed)
- Condenser Liquid Flow Switch
- Condenser Liquid Pump (Run/Stop)
- Refrigerant Level Position
- Refrigerant Level Setpoint
- Ramp Up Time Remaining

The **COMPRESSOR** screen displays a cutaway view of the compressor, this reveals the impeller and shows all the conditions associated with the compressor. When the compressor impeller is spinning this indicates that the chiller is presently in RUN condition. With the proper access level, the pre-rotation vanes may be manually controlled. This screen also serves as a gateway to sub-screens for calibrating the pre-rotation vanes, the proximity probe, configuring the Hot Gas Bypass, or providing advanced control of the compressor motor Variable Speed Drive. From this screen you can view the following:

Display Only

- Oil Pressure
- Oil Sump Temperature
- Discharge Temperature
- High Speed Thrust Bearing Oil Drain Temperature
- High Speed Thrust Bearing Proximity Differential
- High Speed Thrust Solenoid (LED)
- Vane Motor Switch (LED)
- Oil Return Solenoid (LED)
- Vent Line Solenoid (LED)
- Liquid Line Solenoid (LED)
- Oil Pump Drive Command Frequency (VS OIL Pump Only)

The **OIL SUMP** screen displays a close-up view of the chiller oil sump and provides all the necessary setpoints for maintaining the Variable Speed Oil Pump (VSOP). This screen also allows manual control of the Frequency Command sent to the VSOP. From this screen you can perform the following:

Display Only

- Oil Sump Temperature
- Sump Oil Pressure (LOP)
- Pump Oil Pressure (HOP)
- Oil Pressure
- Oil Pump Run Output (LED)
- Oil Return Solenoid (LED)
- Oil Heater (LED – VSOP Only)
- Target/Setpoint Oil Pressure (VSOP Only)
- Pulldown Time Remaining (VSOP Only)
- Variable Speed Oil Pump Control Mode (VSOP Only)
- Oil pump Drive Command Frequency (VSOP Only)
- Manual Oil Pump Operation Time Left

Programmable

- **Manual Pump**

The **MOTOR** “soft” key on the Home screen when pressed shows a picture of either a YORK Electro-Mechanical Starter, Solid State Starter or a Variable Speed Drive Screen depending on chiller configuration. Programmable pulldown demand to automatically limit motor loading for minimizing building demand charges. Pulldown time period control over four hours, and verification of time remaining in pulldown cycle from display readout. Separate digital setpoint for current limiting between 30 and 100%.

OptiView Control Center (continued)

The **ELECTRO-MECHANICAL STARTER – (E-M)** screen displays a picture of the starter and the following values, the ones below are common among all three offerings and the values will be displayed on all types of starter screens. From this screen you can perform the following:

Display Only

- Motor Run (LED)
- Motor Current %Full Load Amps
- Current Limit Setpoints
- Pulldown Demand Time Left

Programmable

- Local Motor Current Limit
- Pulldown Demand Limit
- Pulldown Demand Time

The **SOLID STATE STARTER – (SSS)** screen displays a picture of the starter and following values that are displayed in addition to the common ones listed above.

Display Only

- Scale/Model
- Voltage – Phase A, B, C
- Current – Phase A, B, C
- Input Power
- Kilowatt hours

The **VARIABLE SPEED DRIVE - (VSD)** screen displays a picture of the VSD and the following values that are in addition to the common ones listed above. From this screen you can view the following:

Display Only

- Output Voltage
- Output Frequency
- Current – Phase A, B, C
- Input Power
- kW Hours
- Pre-Rotation Vane Position
- Harmonic Filter Data (Filter option only)
 - Supply KVA
 - Total Power Factor
 - Voltage Total Harmonic Distortion – L1, L2, L3
 - Supply Current Total Demand Distortion – L1, L2, L3

There are two additional screens (Sub-screens) that have

further VSD information. From these screens you can view the following:

1. Variable Speed Drive Details

Display Only

- Water Pump Output (LED)
- Precharge Relay Output (LED)
- Trigger SCR Output (LED)
- DC Bus Voltage
- DC Inverter Link Current
- Internal Ambient Temperature
- Converter Heatsink Temperature
- Heatsink Temperature – Phase A, B, C
- Motor HP
- 100% Full Load Amps

2. Harmonic Filter Details (Filter option only)

Display Only

- Operating Mode (Run/Stop)
- DC Bus Voltage
- Supply Contactor (LED)
- Precharge Contactor (LED)
- Phase Rotation
- Total Supply KVA
- Base Plate Heatsink Temperature
- Voltage Peak (N-L1, N-L2, N-L3)
- RMS Voltage (L1, L2, L3)
- Voltage Total Harmonic Distortion (L1, L2, L3)
- RMS Filter Current (L1, L2, L3)
- Supply Current Total Demand Distortion
- RMS Supply Current L1, L2, L3

The **SETPOINTS** screen provides a convenient location for programming the most common setpoints involved in the chiller control. The Setpoints are shown on other individual screens but to cut down on needless searching they are on this one screen. This screen also serves as a gateway to a sub-screen for defining the setup of general system parameters. From this screen you can perform the following:

Display Only

- Leaving Chilled Liquid Temperature – Setpoint
- Leaving Chilled Liquid Temperature Cycling – Shutdown

- Leaving Chilled Liquid Temperature Cycling – Restart

Programmable

- Local Leaving Chilled Liquid Temperature – Range
- Local Leaving Chilled Liquid Temperature – Setpoint
- Leaving Chilled Liquid Temperature Cycling Offset – Shutdown
- Leaving Chilled Liquid Temperature Cycling Offset – Restart
- Motor Current Limit
- Pulldown Demand Limit
- Pulldown Demand Time
- Print

The **SETUP** is the top level of the general configuration parameters. It allows programming of the time and date, along with specifications as to how the time will be displayed. In addition, the chiller configuration as determined by the microboard program jumpers and program switches is displayed. From this screen you can perform the following:

Display Only

- Chilled Liquid Pump Operation: (Displays Standard or Enhanced)
- Motor Type: (Displays Fixed Speed or Variable Speed)
- Refrigerant Selection: (Displays R-22 or R134a)
- Anti-Recycle: (Displays Disabled or Enabled)
- Power Failure Restart: (Displays Manual or Automatic)
- Liquid Type: (Water or Brine)
- Coastdown: (Displays Standard or Enhanced)
- Pre-Run: (Displays Standard or Extended)
- Oil Pump Package: (Displays Fixed Speed or Variable Speed)
- Power Line Frequency (VSD only): (Displays 60 Hz or 50 Hz)

Programmable

- Set Date
- Set Time
- Clock (Enabled/Disabled)
- 12/24 Hr

The following 6 sub-screens can be accessed from the setup screen:

The **SCHEDULE** screen contains more programmable values than a normal display screen. Each programmable value is not linked to a specific button; instead the select key is used to enable the cursor arrows and check key to program the Start/Stop times for any day of the week up to **6 weeks** in advance. The user has the ability to define a standard set of Start/Stop times that are utilized every week or specify exceptions to create a special week.

Programmable

- Exception Start/Stop Times
- Schedule (Enable/ Disabled)
- Repeat Sunday Schedule
- Standard Week Start/Stop Times
- Reset All Exception Days
- Select
- Print

The **USER** screen allows definition of the language for the chiller to display and defines the unit of measure.

Programmable

- System Language
- English/Metric Units

The **COMMS** screen allows definition of the necessary communications parameters.

Programmable

- Chiller ID
- Com 2 Baud Rate
- Com 2 Data Bit(s)
- Com 2 Parity Bit(s)
- Com 2 Stop Bit(s)
- Printer Baud Rate
- Printer Data Bit(s)
- Printer Parity Bit(s)
- Printer Stop Bit(s)

The **PRINTER** screen allows Definition of the necessary communications Parameters for the printer.

Display Only

- Time Remaining Until Next Print

Programmable

OptiView Control Center (continued)

- Log Start Time
- Output Interval
- Automatic Printer Logging (Enabled/Disabled)
- Print Type
- ACC Auto Map Print (Enable/Disabled)
- ACC Map Report
- Print Report
- Print All Histories

The **SALES ORDER** screen allows definition of the order parameters. Note: This information is loaded at the factory or by the installation/service technician.

Display Only

- Model Number
- Panel Serial Number
- Chiller Serial Number
- YORK Order Number
- System Information
- Condenser and Evaporator Design Load Information
- Nameplate Information

The **OPERATIONS** screen allows definition of parameters related to the operation of the chiller. What is defined is whether the control of the chiller will be Local, Digital Remote, Analog Remote, Modem Remote or Metasys™ Remote.

Programmable

- Control Source

The **HISTORY** screen allows the user to browse through the last ten faults; either safety or cycling shutdowns with the conditions while the chiller is running or stopped. The faults are color coded for ease in determining the severity at a glance, recording the date, time and description. **(See Display Messages for Color Code meanings.)**

Display Only

- Last Normal Shutdown
- Last Fault While Running
- Last Ten Faults

Programmable

- Print History
- Print All Histories

By pressing the **VIEW DETAILS** key you will move to the **HISTORY DETAILS** screen. From these screens you

are able to see an on-screen printout of all the system parameters at the time of the selected shutdown.

Display Only

- History Printout

Programmable

- Page Up
- Page Down
- Print History

Also under the **History** screen is the **TRENDING** screen, accessible by the key marked the same. On this screen up to 6 operator-selected parameters selected from a list of over 140, can be plotted in an X/Y graph format. The graph can be customized to record points once every second up to once every hour. There are two types of charts that can be created: a single or continuous screen. The single screen collects data for one screen width (450 data points across the x-axis) then stops. The continuous screen keeps collecting the data but the oldest data drops off the graph from left to right at the next data collection interval. For ease of identification, each plotted parameter, title and associated Y- axis labeling is color coordinated.

Display Only

- This screen allows the user to view the graphical trending of the selected parameters and is a gateway to the graph setup screens.

Programmable

- Start
- Stop
- Y-axis
- X-axis

The **TREND SETUP** screen is used to configure the trending screen. The parameters to be trended are selected from the Trend Common Slots Screen accessed from the Slot #s button or the Master Slot Numbers List found in the operating manual. The interval at which all the parameters are sampled is selected under the Collection Interval button. The data point min. and max. values may be adjusted closer within the range to increase viewing resolution.

Programmable

- Chart Type (select Continuous or One Screen)
- Collection Interval
- Select
- Data Point Slot # (1-6)

- Data Point Min (1-6)
- Data Point Max (1-6)

The **TREND COMMON SLOTS** screen displays the Master Slot Numbers List of the monitored parameters.

Display Only

- Slot Numbers

Programmable

- Page Up
- Page Down

DISPLAY MESSAGES

The Control Center continually monitors the operating system displaying and recording the cause of any shutdowns (Safety, Cycling or Normal). The condition of the chiller is displayed at the System Status line that contains a message describing the operating state of the chiller; whether it is stopped, running, starting or shutting down. A System Details line displays Warning, Cycling, Safety, Start Inhibit and other messages that provide further details of Status Bar messages. Messages are color-coded: Green – Normal Operations, Yellow - Warnings, Orange – Cycling Shutdowns, and Red – Safety Shutdowns to aid in identifying problems quickly.

Status Messages include:

- System Ready to Start
- Cycling Shutdown – Auto Restart
- Safety Shutdown – Manual Restart
- System Prelube (with countdown timers)
- System Run (with countdown timers)
- System Coastdown (with countdown timers)
- Start Inhibit
- Vanes Closing Before Shutdown

Run Messages include:

- Leaving Chilled Liquid Control
- Current Pulldown Limit

Start Inhibit Messages include:

- Anti-Recycle XX Min/Sec
- Vane Motor Switch Open
- Motor Current >15% FLA

Warning Messages include:

- Real Time Clock Failure
- Condenser or Evaporator Transducer Error
- Refrigerant level Out-of-Range
- Standby Lube – Low Oil Pressure
- Setpoint Override
- Condenser – High Pressure Limit
- Evaporator – Low Pressure Limit
- Motor – High Current Limit (**E-M and SSS options only**)
- Vane Uncalibrated – Fixed Speed (**VSD option only**)

(Filter option only)

- Harmonic Filter – Operation Inhibited
- Harmonic Filter – Data Loss
- Harmonic Filter – Input Frequency Range

Routine Shutdown Messages include:

- Remote Stop
- Local Stop
- Place Compressor Switch in Run Position

Cycling Shutdown Messages include:

- Multi Unit Cycling – Contacts Open
- System Cycling – Contacts Open
- Oil – Low Temperature Differential
- Oil – Low Temperature
- Control Panel – Power Failure
- Leaving Chilled Liquid – Low Temperature
- Leaving Chilled Liquid – Flow Switch Open
- Condenser – Flow Switch Open
- Motor Controller – Contacts Open
- Motor Controller – Loss of Current
- Power Fault
- Control Panel – Schedule
- Starter – Low Supply Line Voltage (**SSS option only**)
- Starter – High Supply Line Voltage (**SSS option only**)
- Proximity Probe – Low Supply Voltage
- Oil – Variable Speed Pump – Drive Contacts Open

Compressor Motor Variable Speed Drive: Cycling Shutdown Messages include (VSD only):

OptiView Control Center (continued)

- VSD Shutdown – Requesting Fault Data
- VSD – Stop Contacts Open
- VSD – Initialization Failed
- VSD – High Phase A, B, C Instantaneous Current
- VSD – Phase A, B, C Gate Driver
- VSD – Single-Phase Input Power
- VSD – High DC Bus Voltage
- VSD – Logic Board Power Supply
- VSD – Low DC Bus Voltage
- VSD – DC Bus Voltage Imbalance
- VSD – Precharge – DC Bus Voltage Imbalance
- VSD – High Internal Ambient Temperature
- VSD – Invalid Current Scale Selection
- VSD – Low Phase A, B, C Inverter Heatsink Temperature
- VSD – Low Converter Heatsink Temperature
- VSD – Precharge – Low DC Bus Voltage
- VSD – Logic Board Processor
- VSD – Run Signal
- VSD – Serial Communications

(Filter option only)

- Harmonic Filter – Logic Board or Communications
- Harmonic Filter – High DC Bus Voltage
- Harmonic Filter – High Phase A, B, C Current
- Harmonic Filter – Phase Locked Loop
- Harmonic Filter – Precharge – Low DC Bus Voltage
- Harmonic Filter – Low DC Bus Voltage
- Harmonic Filter – DC Bus Voltage Imbalance
- Harmonic Filter – 110% Input Current Overload
- Harmonic Filter – Logic Board Power Supply
- Harmonic Filter – Run Signal
- Harmonic Filter – DC Current Transformer 1
- Harmonic Filter – DC Current Transformer 2

Safety Shutdown Messages include:

- Evaporator – Low Pressure
- Evaporator – Transducer or Leaving Liquid Probe
- Evaporator – Transducer or Temperature Sensor

- Condenser – High Pressure Contacts Open
- Condenser – High Pressure
- Condenser – Pressure Transducer Out-of-Range
- Auxiliary Safety – Contacts Closed
- Discharge – High Temperature
- Discharge – Low Temperature
- Oil – High Temperature
- Oil – Low Differential Pressure
- Oil – High Differential Pressure
- Oil – Pump Pressure Transducer Out-of-Range
- Transducer Out-of-Range
- Oil – Differential Pressure Calibration
- Oil – Variable Speed Pump – Setpoint Not Achieved
- Control Panel – Power Failure
- Motor Or Starter – Current Imbalance (**SSS option only**)
- Thrust Bearing – Proximity Probe Clearance (K Compressor)
- Thrust Bearing – Proximity Probe Out Of Range (K Compressor)
- Thrust Bearing – Position Switch (P, Q, & H9 Compressors)
- Watchdog – Software Reboot

Compressor Motor VSD: Safety Shutdown Messages include: (VSD only)

- VSD Shutdown – Requesting Fault Data
- VSD – Stop contacts Open
- VSD – 105% Motor Current Overload
- VSD – High Phase A, B, C Inverter Heatsink Temperature
- VSD – High Converter Heatsink Temperature
- VSD – Precharge Lockout

(Filter option only)

- Harmonic Filter – High Heatsink Temperature
- Harmonic Filter – High Total Demand Distortion

Mechanical Specifications

GENERAL

The YORK **MaxE** Centrifugal Liquid Chillers are completely factory-packaged including the evaporator, condenser, compressor, motor, lubrication system, control center, and all interconnecting unit piping and wiring.

The initial charge of refrigerant and oil is supplied for each chiller. When the optional condenser isolation valves are ordered, most units may ship fully charged with refrigerant and oil. Actual shipping procedures will depend on a number of project-specific details.

The services of a YORK factory-trained, field service representative are incurred to supervise or perform the final leak testing, charging, the initial start-up, and concurrent operator instructions.

COMPRESSOR

The compressor is a single-stage centrifugal type powered by an open-drive electric motor. The casing is fully accessible with vertical circular joints and fabricated of close-grain cast iron. The complete operating assembly is removable from the compressor and scroll housing.

The rotor assembly consists of a heat-treated alloy steel drive shaft and impeller shaft with a high strength, cast aluminum alloy, fully shrouded impeller. The impeller is designed for balanced thrust and is dynamically balanced and overspeed tested for smooth, vibration free operation.

The insert-type journal and thrust bearings are fabricated of aluminum alloy and are precision bored and axially grooved. The specially engineered, single helical gears with crowned teeth are designed so that more than one tooth is in contact at all times to provide even distribution of compressor load and quiet operation. Gears are integrally assembled in the compressor rotor support and are film lubricated. Each gear is individually mounted in its own journal and thrust bearings to isolate it from impeller and motor forces.

CAPACITY CONTROL

Pre-rotation vanes (PRV) modulate chiller capacity from 100% to 15% of design for normal air conditioning applications. Operation is by an external, electric PRV actuator which automatically controls the vane position to maintain a constant leaving chilled liquid temperature. Rugged airfoil shaped cast manganese bronze vanes are precisely positioned by solid vane linkages connected to the electric actuator.

LUBRICATION SYSTEM

Lubrication oil is force-fed to all bearings, gears and rotating surfaces by a variable speed drive pump which operates prior to startup, continuously during operation and during coastdown. A gravity-fed oil reservoir is built into the top of the compressor to provide lubrication during

coastdown in the event of a power failure.

An oil reservoir, separate from the compressor, contains the submersible oil pump, 2 HP pump motor and 3000 watt immersion-type oil heater. The oil heater is thermostatically controlled to remove refrigerant from the oil.

Oil is filtered by an externally mounted 1/2 micron replaceable cartridge oil filter equipped with service valves. Oil is cooled via a refrigerant-cooled oil cooler, eliminating the requirement for field water piping. The oil side of the oil cooler is provided with service valves. An automatic oil return system recovers any oil that may have migrated to the evaporator. Oil piping is completely factory-installed.

WATER-COOLED OIL COOLER

Optional condenser water-cooled oil cooler is offered for units with Q3 compressors C-D shells only. This oil cooler is a shell and tube heat exchanger. Water from condenser supply water box circulates through the tube side of the heat exchanger and discharges back into the return side of the water box. Hot oil circulates through the tubes within the oil cooler, and is cooled by the cold condenser water. The cooled oil is then sent back to the compressor through a temperature regulator valve and oil filters. Both the oil and water piping are completely factory-installed, eliminating the requirement for field piping.

MOTOR DRIVELINE

The compressor motor is an open drip-proof, squirrel cage, induction type constructed to YORK design specifications. 60 hertz motors operate at 3570 rpm. 50 hertz motors operate at 2975 rpm.

The open motor is provided with a D-flange, and is factory-mounted to a cast iron adaptor mounted on the compressor. This unique design allows the motor to be rigidly coupled to the compressor to provide factory alignment of motor and compressor shafts.

Motor drive shaft is directly connected to the compressor shaft with a flexible disc coupling. Coupling has all metal construction with no wearing parts to assure long life, and no lubrication requirements to provide low maintenance.

For units utilizing remote electro-mechanical starters, a large, steel terminal box with gasketed front access cover is provided for field-connected conduit. There are six terminals (three for medium voltage) brought through the motor casing into the terminal box. Jumpers are furnished for three-lead types of starting. Motor terminal lugs are not furnished. Overload/over-current transformers are furnished with all units. For units furnished with factory-packaged Solid State Starters or Variable Speed Drive, refer to the Accessories and Modifications Section.

Mechanical Specifications (continued)

HEAT EXCHANGERS

Shells

Evaporator and condenser shells are fabricated from rolled carbon steel plates with fusion welded seams or carbon steel pipe. Carbon steel tube sheets, drilled and reamed to accommodate the tubes, are welded to the end of each shell. Intermediate tube supports are fabricated from carbon steel plates, drilled and reamed to eliminate sharp edges, and spaced no more than four feet apart. The refrigerant side of each shell is designed, tested, and stamped in accordance with ASME Boiler and Pressure Vessel Code, Section VIII – Division I, or other pressure vessel code as appropriate.

Tubes

Heat exchanger tubes are state-of-the-art, high-efficiency, externally and internally enhanced type to provide optimum performance. Tubes in both the evaporator and condenser are 3/4" O.D. standard (or 1" optional in some shells) copper alloy and utilize the "skip-fin" design, providing a smooth internal and external surface at each intermediate tube support. This provides extra wall thickness (up to twice as thick) and non work-hardened copper at the support location, extending the life of the heat exchangers. Each tube is roller expanded into the tube sheets providing a leak-proof seal, and is individually replaceable.

Evaporator

The evaporator is a shell and tube, flooded type heat exchanger. A distributor trough provides uniform distribution of refrigerant over the entire shell length to yield optimum heat transfer. A suction baffle or aluminum mesh eliminators are located above the tube bundle to prevent liquid refrigerant carryover into the compressor. A 1-1/2" liquid level sight glass is conveniently located on the side of the shell to aid in determining proper refrigerant charge. The evaporator shell contains a dual refrigerant relief valve arrangement set at 180 PSIG (1241 kPa) on H and K Compressor models; 235 PSIG (1620 kPa) on P and Q Compressor Models; or single-relief valve arrangement, if the chiller is supplied with the optional refrigerant isolation valves. A 1" refrigerant charging valve is provided.

Condenser

The condenser is a shell and tube type, with a discharge gas baffle to prevent direct high velocity impingement on the tubes. The baffle is also used to distribute the refrigerant gas flow properly for most efficient heat transfer. An optional cast steel condenser inlet diffuser may be offered, on "M" and larger condensers, in lieu of the baffle, to provide dynamic pressure recovery and enhanced chiller efficiency. An integral sub-cooler is located at the bottom of the condenser shell providing highly effective

liquid refrigerant subcooling to provide the highest cycle efficiency. The condenser contains dual refrigerant relief valves set at 235 PSIG (1620 kPa).

Water Boxes

The removable water boxes are fabricated of steel. The design working pressure is 150 PSIG (1034 kPa) and the boxes are tested at 225 PSIG (1551 kPa). Integral steel water baffles are located and welded within the water box to provide the required pass arrangements. Stub-out water nozzle connections with Victaulic grooves are welded to the water boxes. These nozzle connections are suitable for Victaulic couplings, welding or flanges, and are capped for shipment. Plugged 3/4" drain and vent connections are provided in each water box.

WATER FLOW SWITCHES

Thermal type water flow switches are factory mounted in the chilled and condenser water nozzles, and are factory wired to the Optiview control panel. These solid state flow sensors have a small internal heating element. They use the cooling effect of the flowing fluid to sense when an adequate flow rate has been established. The sealed sensor probe is 316 stainless steel, which is suited to very high working pressures.

REFRIGERANT FLOW CONTROL

Refrigerant flow to the evaporator is controlled by the YORK variable orifice control system. Liquid refrigerant level is continuously monitored to provide optimum subcooler, condenser and evaporator performance. The variable orifice electronically adjusts to all Real-World operating conditions, providing the most efficient and reliable operation of refrigerant flow control.

OPTIVIEW CONTROL CENTER

General

The chiller is controlled by a stand-alone microprocessor based control center. The chiller control panel provides control of chiller operation and monitoring of chiller sensors, actuators, relays and switches.

Control Panel

The control panel includes a 10.4-in. diagonal color liquid crystal display (LCD) surrounded by "soft" keys which are redefined based on the screen displayed at that time, mounted in the middle of a keypad interface and installed in a locked enclosure. The screen details all operations and parameters, using a graphical representation of the chiller and its major components. Panel verbiage is available in eight languages and can be changed on the fly without having to turn off the chiller. Data can be

displayed in either English or Metric units. Smart Freeze Point Protection will run the chiller at 36°F (2.2°C) leaving chilled water temperature, and not have nuisance trips on low water temperature. The sophisticated program and sensor monitors the chiller water temperature to prevent freeze-up. When needed, Hot Gas Bypass is available as an option. The panel displays countdown timer messages so the operator knows when functions are starting and stopping. Every programmable point has a pop-up screen with the allowable ranges, so that the chiller can not be programmed to operate outside of its design limits. The chiller control panel also provides:

1. System operating information including:
 - a. return and leaving chilled water temperature
 - b. return and leaving condenser water temperature
 - c. evaporator and condenser saturation pressure
 - d. differential oil pressure
 - e. percent motor current
 - f. evaporator and condenser saturation temperature
 - g. compressor discharge temperature
 - h. oil reservoir temperature
 - i. compressor thrust bearing positioning (K compressors only)
 - j. operating hours
 - k. number of compressor starts
2. Digital programming of setpoints through the universal keypad including:
 - a. leaving chilled water temperature
 - b. percent current limit
 - c. pull-down demand limiting
 - d. six-week schedule for starting and stopping the chiller, pumps and tower
 - e. remote reset temperature range
3. Status messages indicating:
 - a. system ready to start
 - b. system running
 - c. system coastdown
 - d. system safety shutdown – manual restart
 - e. system cycling shutdown – auto restart
 - f. system prelube
 - g. start inhibit
4. The text displayed within the system status and system details field is displayed as a color-coded message to indicate severity: red for safety fault, orange for cycling faults, yellow for warnings, and green for normal messages.
5. Safety shutdowns enunciated through the display and the status bar, and consist of system status, system details, day, time, cause of shutdown, and type of restart required. Safety shutdowns with a fixed speed drive include:
 - a. evaporator – low pressure
 - b. evaporator – transducer or leaving liquid probe
 - c. evaporator – transducer or temperature sensor
 - d. condenser – high pressure contacts open
 - e. condenser – high pressure
 - f. condenser – pressure transducer out-of-range
 - g. auxiliary safety – contacts closed
 - h. discharge – high temperature
 - i. discharge – low temperature
 - j. oil – high temperature
 - k. oil – low differential pressure
 - l. oil – high differential pressure
 - m. oil – sump pressure transducer out-of-range
 - n. oil – differential pressure calibration
 - o. oil – variable speed pump – pressure setpoint not achieved
 - p. control panel – power failure
 - q. motor or starter – current imbalance
 - r. thrust bearing – proximity probe clearance (K compressors only)
 - s. thrust bearing – proximity probe out-of-range (K compressors only)
 - t. thrust bearing – position switch (P, Q & H9 compressors)
 - u. watchdog – software reboot
- 5.1 Safety shutdowns with a VSD include:
 - a. VSD shutdown – requesting fault data
 - b. VSD – stop contacts open
 - c. VSD – 105% motor current overload
 - d. VSD – high phase A, B, C inverter heatsink temp.
 - e. VSD – high converter heatsink temperature

(Filter Option Only)

 - f. harmonic filter – high heatsink temperature
 - g. harmonic filter – high total demand distortion
6. Cycling shutdowns enunciated through the display and the status bar, and consists of system status,

Mechanical Specifications (continued)

system details, day, time, cause of shutdown, and type of restart required.

Cycling shutdowns with a fixed speed drive include:

- a. multi unit cycling – contacts open
- b. system cycling – contacts open
- c. oil – low temperature differential
- d. oil – low temperature
- e. control panel – power failure
- f. leaving chilled liquid – low temperature
- g. leaving chilled liquid – flow switch open
- h. motor controller – contacts open
- i. motor controller – loss of current
- j. power fault
- k. control panel – schedule
- l. starter – low supply line voltage (SSS option)
- m. starter – high supply line voltage (SSS option)
- n. proximity probe – low supply voltage (K Compressor)
- o. oil – variable speed pump – drive contacts open

6.1 Cycling shutdowns with a VSD include:

- a. VSD shutdown – requesting fault data
- b. VSD – stop contacts open
- c. VSD – initialization failed
- d. VSD – high phase A, B, C instantaneous current
- e. VSD – phase A, B, C gate driver
- f. VSD – single phase input power
- g. VSD – high DC bus voltage
- h. VSD – precharge DC bus voltage imbalance
- i. VSD – high internal ambient temperature
- j. VSD – invalid current scale selection
- k. VSD – low phase A, B, C inverter heatsink temp.
- l. VSD – low converter heatsink temperature
- m. VSD – precharge – low DC bus voltage
- n. VSD – logic board processor
- o. VSD – run signal
- p. VSD – serial communications

(Filter Option Only)

- q. harmonic filter – logic board or communications
 - r. harmonic filter – high DC bus voltage
 - s. harmonic filter – high phase A, B, C current
 - t. harmonic filter – phase locked loop
 - u. harmonic filter – precharge – low DC bus voltage
 - v. harmonic filter – DC bus voltage imbalance
 - w. harmonic filter – 110% input current overload
 - x. harmonic filter – logic board power supply
 - y. harmonic filter – run signal
 - z. harmonic filter – DC current transformer 1
 - aa. harmonic filter – DC current transformer 2
7. Security access to prevent unauthorized change of setpoints, to allow local or remote control of the chiller, and to allow manual operation of the pre-rotation vanes and oil pump. Access is through ID and password recognition, which is defined by three different levels of user competence: view, operator, and service.
 8. Trending data with the ability to customize points of once every second to once every hour. The panel will trend up to 6 different parameters from a list of over 140, without the need of an external monitoring system.
 9. The operating program stored in non-volatile memory (EPROM) to eliminate reprogramming the chiller due to AC power failure or battery discharge. Programmed setpoints are retained in lithium battery-backed RTC memory for a minimum of 11 years with power removed from the system.
 10. A fused connection through a transformer in the compressor motor starter to provide individual over-current protected power for all controls.
 11. A numbered terminal strip for all required field interlock wiring.
 12. An RS-232 port to output all system operating data, shutdown/cycling message, and a record of the last 10 cycling or safety shutdowns to a field-supplied printer. Data logs to a printer at a set programmable interval. This data can be preprogrammed to print from 1 minute to 1 day.
 13. The capability to interface with a building automation system via hard-wired connections to each feature to provide:
 - a. remote chiller start and stop

- b. remote leaving chiller liquid temperature adjust
- c. remote current limit setpoint adjust
- d. remote ready to start contacts
- e. safety shutdown contacts
- f. cycling shutdown contacts
- g. run contacts

CODES AND STANDARDS

- ASME Boiler and Pressure Vessel Code – Section VIII Division 1.
- ARI Standard 550/590
- c/U.L. – Underwriters Laboratory
- ASHRAE 15 – Safety Code for Mechanical Refrigeration
- ASHRAE Guideline 3 – Reducing Emission of Halogenated Refrigerants in Refrigeration and Air-Conditioning Equipment and Systems
- N.E.C. – National Electrical Code
- OSHA – Occupational Safety and Health Act

ISOLATION MOUNTING

The unit is provided with four vibration isolation mounts of nominal 1" operating height. The pads have a neoprene

pad to contact the foundation, bonded to a steel plate. The vibration isolation pads assemblies mount under steel plates affixed to the chiller tube sheets.

REFRIGERANT CONTAINMENT

The standard unit has been designed as a complete and compact factory-packaged chiller. As such, it has minimum joints from which refrigerant can leak. The entire assembly has been thoroughly leak tested at the factory prior to shipment. The YORK chiller includes service valves conveniently located to facilitate transfer of refrigerant to a remote refrigerant storage/recycling system. Optional condenser isolation valves allow storage of the charge in the condenser.

PAINT

Exterior surfaces are protected with one coat of Caribbean blue, durable alkyd-modified, vinyl enamel, machinery paint.

SHIPMENT

Protective covering is furnished on the motor starter, Control Center VSD and unit-mounted controls. Water nozzles are capped with fitted plastic enclosures. Entire unit is protected with industrial-grade, reinforced shrink-wrapped covering.

Accessories and Modifications

LOW VOLTAGE OPTISPEED DRIVE

A 575V 3-phase 60Hz, 460V 3-phase 60 Hz or 400V 3-phase 50 Hz variable speed drive is factory-packaged and mounted on the MAXE chiller. It is designed to vary the compressor motor speed by controlling the frequency and voltage of the electrical power to the motor. The adaptive capacity control logic automatically adjusts motor speed and compressor pre-rotation vane position independently for maximum part load efficiency by analyzing information fed to it by sensors located throughout the chiller.

The variable speed drive is mounted in a NEMA-1 enclosure with all power and control wiring between the drive and chiller factory-installed. Electrical lugs for incoming power wiring are provided, and the entire chiller package is UL/cUL listed.

The variable speed drive provides automatic power factor correction to 0.95 or better at all load conditions. Separate power factor correction capacitors are not required. The power factor is 0.98 or better when the optional harmonic filter is provided.

Standard features include: a door interlocked padlockable circuit breaker; UL/cUL listed ground fault protection; over-voltage and under-voltage protection; 3-phase sensing motor over-current protection; single-phase protection; insensitive to phase rotation; over-temperature protection; digital readout at the OptiView Control Center of:

- Output Frequency
- Output Voltage
- 3-phase output current
- Input Power (KW)
- Self diagnostic service parameters
- Kilowatt-Hours (KWH)

An optional harmonic filter limits electrical power supply distortion from the variable speed drive to comply with the guidelines of IEEE Std. 519-1992. The filter is unit-mounted within the same NEMA-1 enclosure and is UL listed. The following digital readout is standard with the optional filter:

- Input KVA
- Total power factor
- 3-phase input voltage
- 3-phase input current
- 3-phase input voltage total harmonic distortion (THD)
- 3-phase input current total demand distortion (TDD)
- Self diagnostic service parameters

LOW VOLTAGE SOLID STATE STARTER

The Solid State Starter is a reduced voltage starter that controls and maintains a constant current flow to the motor during startup. It is compact and mounted on the unit. Power and control wiring between the starter and the chiller are factory-installed. Available for 200 - 600 volts, the starter enclosure is NEMA-1, with a hinged access door with lock and key. Electrical lugs for incoming power wiring are provided.

Standard Features include digital readout at the OptiView Control Center of the following:

Display Only

- 3-phase input voltage
- 3-phase current
- Input Power (kW)
- Killowatt-Hours (KWH)
- Starter Model
- Motor Run (LED)
- Motor Current % Full Load Amps
- Current Limit Setpoints
- Pulldown Demand Time Left Programmable
- Local Motor Current Limit
- Pulldown Demand Limit
- Pulldown Demand Time

Other features include: low line voltage; 115-volt control transformer; three-leg motor current sensing overloads; phase rotation and single-phase failure protection; high temperature safety protection; motor current imbalance and under-voltage safeties; open and shorted SCR protection; momentary power interruption protection. The Solid State Starter is cooled by a closed loop, fresh water circuit consisting of a water-to-water heat exchanger and 1/25 HP circulating pump. All interconnecting water piping is factory-installed and rated for 150 PSIG working pressure. Optional electronic trip circuit UL listed circuit breaker with integral ground fault protection is available with short circuit withstand ratings of:

65KA for 460V 200V, 400V models
50KA for 33L 575V models
35KA for 14L 575V models
22KA for 7L 575V models

A non-fused disconnect switch is also available. Both options are padlockable.

MEDIUM VOLTAGE OPTISPEED DRIVE

A 4160V 3-phase 60Hz, 2300V 3-phase 60 Hz or 3300V 3-phase 50 Hz variable speed drive is factory-packaged and configured for easy remote mounting. It is designed to vary the compressor motor speed by controlling the frequency and voltage of the electrical power to the motor. The adaptive capacity control logic automatically adjusts motor speed and compressor pre-rotation vane position independently for maximum part load efficiency by analyzing information fed to it by sensors located throughout the chiller.

The variable speed drive is mounted in a NEMA-1 enclosure and comes with a UL/cUL label. The connection points between the drive and chiller are factory labeled. Electrical lugs for incoming power wiring are NOT provided.

The variable speed drive provides automatic power factor correction to 0.98 or better at all load conditions. Separate power factor correction capacitors are not required.

Standard features include: a door interlocked padlockable disconnect switch; UL listed ground fault protection; over-voltage and under-voltage protection; 3-phase sensing motor over-current protection; single-phase protection; insensitive to phase rotation; over-temperature protection; digital readout at the OptiView Control Center of:

- Output frequency
- 3-phase output voltage
- 3-phase output current
- Input power (kW)
- Self diagnostic service parameters
- Kilowatt-hours (kWH)
- Input KVA
- Total power factor
- 3-phase input voltage
- 3-phase input current
- Self diagnostic service parameters

The 24 pulse design limits electrical the power supply distortion from the variable speed drive to comply with the guidelines of IEEE Std. 519-1992.

MEDIUM VOLTAGE SOLID STATE STARTER

The Solid State Starter is a reduced voltage in-line bypass starter that controls and maintains a constant current flow to the motor during startup. Power and control wiring between the starter and the chiller are factory-installed. Available for 4160V 3-phase 60Hz, 2300V 3-phase 60 Hz or 3300V 3-phase 50 Hz applications, the starter enclosure is NEMA-1, with a hinged access door with lock and key. Electrical lugs for incoming power wiring

are not provided.

Standard Features include digital readout at the OptiView Control Center of the following:

Display Only

- 3-phase input voltage
- 3-phase current
- Input Power (kW)
- Killowatt-Hours (KWH)
- Starter Model
- Motor Run (LED)
- Motor Current % Full Load Amps
- Current Limit Setpoints
- Pulldown Demand Time Left Programmable
- Local Motor Current Limit
- Pulldown Demand Limit
- Pulldown Demand Time

Other features include: low line voltage; 115-volt control transformer; three-leg motor current sensing overloads; phase rotation and single-phase failure protection; high temperature safety protection; motor current imbalance and under-voltage safeties; open and shorted SCR protection; momentary power interruption protection. The Solid State Starter is air cooled generating about the same heat as an auto-transformer E-M starter. Ground fault protection and surge protection are also standard features. The 50,000 amp short circuit withstand rating is in accordance with UL Standard 508.

BAS REMOTE CONTROL

A communication interface permitting complete exchange of chiller data with any BAS System is available with an optional Metasys™ translator. The Metasys™ translator also allows BAS System to issue commands to the chiller to control its operation. Metasys™ translators come in two models, controlling up to 4 chillers and 8 chillers respectively.

FACTORY INSULATION OF EVAPORATOR

Factory-applied thermal insulation of the flexible, closed-cell plastic type, 3/4" (19 mm) thick is attached with vapor-proof cement to the evaporator shell, flow chamber, tube sheets, suction connection, and (as necessary) to the auxiliary tubing. Not included is the insulation of compact water boxes and nozzles. This insulation will normally prevent condensation in environments with relative humidifies up to 75% and dry bulb temperatures ranging from 50° to 90°F (10° to 32.2°C). 1 1/2" (38 mm)

Accessories and Modifications (continued)

thick insulation is also available for relative humidities up to 90% and dry bulb temperatures ranging from 50° to 90°F (10° to 32.2°C).

WATER FLANGES

Four 150 lb. ANSI raised-face flanges for condenser and evaporator water connections are factory-welded to water nozzles. Companion flanges, bolts, nuts and gaskets are not included.

SPRING ISOLATION MOUNTING

Spring isolation mounting is available instead of standard isolation mounting pads when desired. Four level-adjusting, spring-type vibration isolator assemblies with non-skid pads are provided for field-installation. Isolators are designed for one-inch (25 mm) deflection.

SEQUENCE CONTROL KIT

For two, three or four units with chilled water circuits connected in series or parallel, the kit consists of return water thermostat, lead-lag selector switch for sequence starting, and time delay relay, with NEMA-1 enclosures, designed for 115V-1-50/60 service.

STARTER - FIELD-INSTALLED

A field-installed, electro-mechanical compressor motor starter is available, selected for proper size and type for job requirements and in accordance with YORK Engineering Standard (R-1132) for Starters.

MARINE WATER BOXES

Marine water boxes allow service access for cleaning of the heat exchanger tubes without the need to break the water piping. Bolted-on covers are arranged for convenient access. Victaulic nozzle connections are standard; flanges are optional. Marine water boxes are available for condenser and/or evaporator.

KNOCK-DOWN SHIPMENT

The chiller can be shipped knocked down into major subassemblies (evaporator, condenser, driveline, etc.) as required to rig into tight spaces. This is particularly convenient for existing buildings where equipment room access does not allow rigging a factory-packaged chiller.

REFRIGERANT ISOLATION VALVES

Optional factory-installed isolation valves in the compressor discharge line and refrigerant liquid line are available. This allows isolation and storage of the refrigerant charge in the chiller condenser during servicing, eliminating time-consuming transfers to remote storage vessels. Both valves are positive shut-off, assuring integrity of the

storage system.

REFRIGERANT STORAGE/RECYCLING SYSTEM

A refrigerant storage/recycling system is a self-contained package consisting of a refrigerant compressor with oil separator, storage receiver, water-cooled condenser, filter drier and necessary valves and hoses to remove, replace and distill refrigerant. All necessary controls and safety devices are a permanent part of the system. A storage receiver is typically not required if optional unit isolation valves are provided.

HIGH AMBIENT TEMPERATURE

Chiller modifications are available to allow for installation in high ambients 122°F (50°C). Special drive motors are required above 104°F (40°C). H9 and K compressor evaporator design pressures must be increased for ambient temperatures above 112.8°F (45°C). The OptiView panel and low voltage VSD are suited for 122°F (50°C) ambient. Low and medium voltage Solid State Starters must be derated and/or modified above 110°F (43.3°C). The free standing MVVSD option must be derated above its standard 104°F (40°C) limit.

OPTISOUND™ CONTROL

The YORK® OptiSound™ Control is a patented combination of centrifugal-chiller hardware and software that reduces operational sound levels, expands the chiller operating range, and improves chiller performance. The OptiSound Control feature continuously monitors the characteristics of the compressor-discharge gas and optimizes the diffuser spacing to minimize gas-flow disruptions from the impeller. This innovative technology improves operating sound levels of the chiller an average of 7 dBA, and up to 13 dBA on the largest models. It can also reduce part-load sound levels below the full-load level.

In addition, the OptiSound Control provides the benefit of an expanded operating range. It improves performance and reliability by minimizing diffuser-gas stall at off-design operation, particularly conditions of very low load combined with little or no condenser-water relief. The elimination of the gas-stall condition can also result in improved chiller efficiency at off-design conditions.

Johnson Controls recommends the OptiSound Control for chiller applications with elevated entering condenser-water temperatures (high-head) or applications requiring low-load operation with constant condenser temperature. At high-head conditions, improved chiller operation is visible at all load points.

OptiSound Control Availability

Standard: Compressors P8, P9, H9, J5, J7

Optional: Compressors J1-J4

Not Available: Compressors Q3-Q7, P1-P7, H3, H5-H8

Application Data

The following discussion is a user's guide in the application and installation of MAXE chillers to ensure the reliable, trouble-free life for which this equipment was designed. While this guide is directed towards normal, water-chilling applications, the YORK sales representative can provide complete recommendations on other types of applications.

LOCATION

MAXE chillers are virtually vibration free and may generally be located at any level in a building where the construction will support the total system operating weight.

The unit site must be a floor, mounting pad or foundation which is level within 1/4" (6.4 mm) and capable of supporting the operating weight of the unit.

Sufficient clearance to permit normal service and maintenance work should be provided all around and above the unit. Additional space should be provided at one end of the unit to permit cleaning of evaporator and condenser tubes as required. A doorway or other properly located opening may be used.

The chiller should be installed in an indoor location where temperatures range from 40°F to 104°F (4.4°C to 40°C).

WATER CIRCUITS

Flow Rate – For normal water chilling duty, evaporator and condenser flow rates are permitted at water velocity levels in the heat exchangers tubes of between 3 ft/sec (3.3 for condensers) and 12 ft/sec (0.91 m/s and 3.66 m/s). Two pass units are also limited to 45 ft H₂O (134 kPA) water pressure drop. Three pass limit is 67.5 ft H₂O (201 kPA).

Variable flow in the condenser is not recommended, as it generally raises the energy consumption of the system by keeping the condenser pressure high in the chiller. Additionally, the rate of fouling in the condenser will increase at lower water velocities associated with variable flow, raising system maintenance costs. Cooling towers typically have narrow ranges of operation with respect to flow rates, and will be more effective with full design flow. Ref. Table 1 for flow limits at design conditions.

There is increasing interest to use variable primary flow (VPF) systems in large chilled water plants. VPF systems can offer lower installation and operating costs in many cases, but do require more sophisticated control and flow monitoring.

YORK YK chillers will operate successfully in VPF systems. With a minimum allowable evaporator tube velocity of 1-1/2 fps (feet per second) for standard tubes at part-load rating conditions, YK chillers will accommodate the wide variation in flow required by many chilled water VPF

applications.

The chillers can tolerate a 50% flow rate change in one minute that is typically associated with the staging on or off of an additional chiller, however a lower flow rate change is normally used for better system stability and set point control. Proper sequencing via the building automation system will make this a very smooth transition.

Temperature Ranges – For normal water chilling duty, leaving chilled water temperatures may be selected between 38°F (3.3°C) [36°F (2.2°C) with Smart Freeze enabled] and 70°F (21.1°C) for water temperature ranges between 3°F and 30°F (1.7°C and 16.7°C).

Water Quality – The practical and economical application of liquid chillers requires that the quality of the water supply for the condenser and evaporator be analyzed by a water treatment specialist. Water quality may affect the performance of any chiller through corrosion, deposition of heat-resistant scale, sedimentation or organic growth. These will degrade chiller performance and increase operating and maintenance costs. Normally, performance may be maintained by corrective water treatment and periodic cleaning of tubes. If water conditions exist which cannot be corrected by proper water treatment, it may be necessary to provide a larger allowance for fouling, and/or to specify special materials of construction.

General Piping – All chilled water and condenser water piping should be designed and installed in accordance with accepted piping practice. Chilled water and condenser water pumps should be located to discharge through the chiller to assure positive pressure and flow through the unit. Piping should include offsets to provide flexibility and should be arranged to prevent drainage of water from the evaporator and condenser when the pumps are shut off. Piping should be adequately supported and braced independently of the chiller to avoid the imposition of strain on chiller components. Hangers must allow for alignment of the pipe. Isolators in the piping and in the hangers are highly desirable in achieving sound and vibration control.

Convenience Considerations – To facilitate the performance of routine maintenance work, some or all of the following steps may be taken by the purchaser. Evaporator and condenser water boxes are equipped with plugged vent and drain connections. If desired, vent and drain valves may be installed with or without piping to an open drain. Pressure gauges with stop cocks and stop valves may be installed in the inlets and outlets of the condenser and chilled water line as close as possible to the chiller. An overhead monorail or beam may be used to facilitate servicing.

Connections – The standard chiller is designed for 150 PSIG (1034 kPA) design working pressure in both the

Application Data (continued)

TABLE 1 – WATER FLOW RATE LIMITS (GPM) — BASED UPON STANDARD TUBES @ DESIGN FULL LOAD CONDITIONS

Model	Evaporator						Condenser						
	1 Pass		2 Pass		3 Pass		Model	1 Pass		2 Pass		3 Pass	
	Min	Max	Min	Max	Min	Max		Min	Max	Min	Max	Min	Max
AP	329	1316	164	587	110	380	AP	479	1727	240	856	160	576
AQ	403	1613	202	713	134	460	AQ	612	2205	306	1068	204	732
AR	493	1973	247	861	164	552	AR	681	2455	341	1173	227	812
AS	602	2408	301	1032	201	655	AS	770	2773	385	1300		
CP	648	2594	324	1151	216	755	CP	779	2807	389	1397	260	922
CQ	729	2917	365	1286	243	844	CQ	896	3228	448	1590	299	1050
CR	866	3463	433	1509	289	992	CR	1120	4035	560	1941	373	1285
CS	1043	4170	521	1787	348	1176	CS	1397	5035	699	2340		
DP	648	2594	324	988	216	648	DP	779	2807	389	1397	260	793
DQ	729	2917	365	1106	243	725	DQ	896	3228	448	1372	299	906
DR	866	3463	433	1301	289	854	DR	1120	4035	560	1941	373	1114
DS	1043	4170	521	1547	348	1017	DS	1397	5035	699	2340		
EP	859	3438	430	1535	286	1009	EP	1120	4035	560	2017	373	1337
EQ	1046	4183	523	1853	349	1220	EQ	1344	4842	672	2394	448	1590
ER	1232	4927	616	2164	411	1428	ER	1583	5705	792	2779	528	1853
ES	1452	5809	726	2519	484	1667	ES	1750	6308	875	3037	583	2031
ET	1676	6702	838	2865	559	1903	ET	1946	7012	973	3328		
FQ	1046	4183	523	1591	349	1046	FQ	1344	4842	672	2394	448	1368
FR	1232	4927	616	1862	411	1226	FR	1583	5705	792	2405	528	1599
FS	1452	5809	726	2175	484	1436	FS	1750	6308	875	3037	583	1756
FT	1676	6702	838	2482	559	1643	FT	1946	7012	973	3328		
GQ	1443	5771	721	2504	481	1657	EV	1583	5705	792	2779	528	1853
GR	1629	6516	814	2794	543	1855	EW	1750	6308	875	3037	583	2031
GS	1843	7372	922	3115	614	2075	EX	1946	7012	973	3328		
HQ	1443	5771	721	2162	481	1427	FV	1583	5705	792	2405	528	1599
HR	1629	6516	814	2419	543	1600	FW	1750	6308	875	3037	583	1756
HS	1843	7372	922	2707	614	1796	FX	1946	7012	973	3328		
JP	1545	6181	773	2735	515	1807	JP	1583	5705	792	2779	528	1899
JQ	1918	7670	959	3349	639	2224	JQ	1892	6819	946	3249	631	2253
JR	2395	9582	1198	4098	798	2742	JR	2479	8933	1239	4054	826	2903
JS	2616	10463	1308	4427	872	2974	JS	2756	9933	1378	4395		
KP	1545	6181	773	2522	515	1664	KP	1583	5705	792	2779	528	1750
KQ	1918	7670	959	3094	639	2051	KQ	1892	6819	946	3249	631	2078
KR	2395	9582	1198	3797	798	2533	KR	2479	8933	1239	3790	826	2684
KS	2616	10463	1308	4109	872	2750	KS	2756	9933	1378	4395		
KT	1545	6181	773	2522	515	1664							
KV	1918	7670	959	3094	639	2051							
KW	2395	9582	1198	3797	798	2533							
KX	2616	10463	1308	4109	872	2750							
LQ	1918	7670	959	2886	639	1910	LQ	1892	6819	946	2827	631	1936
LR	2395	9582	1198	3550	798	2363	LR	2479	8933	1239	4054	826	2504
LS	2616	10463	1308	3845	872	2567	LS	2756	9933	1378	4395		
							MP	2192	7899	1096	3626	731	2391
MQ	2426	9706	1213	3906	809	2606	MQ	2570	9263	1285	4546	857	2776
MR	2830	11319	1415	4499	943	3022	MR	2949	10626	1474	5140	983	3149
MS	3246	12982	1623	5088	1082	3444	MS	3271	11786	1635	5225		
M2	2003	8013	1002	4006	668	2671	M2	2131	7678	1065	3839	710	2559
M3	2375	9502	1188	4751	792	3167	M3	2639	9510	1319	4755	880	3170
M4	2949	11794	1474	5837	983	3931	M4	3246	11699	1623	5849		
							NP	2192	7899	1096	3926	731	2229
NQ	2426	9706	1213	3644	809	2426	NQ	2570	9263	1285	4546	857	2591
NR	2830	11319	1415	4205	943	2815	NR	2949	10626	1474	4456	983	2943
NS	3246	12982	1623	4763	1082	3210	NS	3271	11786	1635	5625		
N2	2003	8013	1002	3870	668	2580	N2	2131	7678	1065	3839	710	2559
N3	2375	9502	1188	4527	792	3040	N3	2639	9510	1319	4755	880	3170
N4	2949	11794	1474	5484	983	3731	N4	3246	11699	1623	5849		

TABLE 1 – WATER FLOW RATE LIMITS (GPM) — BASED UPON STANDARD TUBES @ DESIGN FULL LOAD CONDITIONS - cont.

Model	Evaporator						Condenser						
	1 Pass		2 Pass		3 Pass		Model	1 Pass		2 Pass		3 Pass	
	Min	Max	Min	Max	Min	Max		Min	Max	Min	Max	Min	Max
PQ	2755	11021	1378	4391	918	2946	PQ	3662	13195	1831	6429	1221	4003
PR	3131	12523	1565	4928	1044	3328	PR	4097	14763	2048	6587	1366	4452
PS	3360	13441	1680	5246	1120	3558	PS	4545	16377	2272	7762		
P2	2523	10093	1262	5046	841	3364	P2	3229	11635	1614	5817	1076	3878
P3	2960	11842	1480	5857	987	3947	P3	3917	14114	1958	7057	1306	4705
P4	3356	13425	1678	6499	1119	4475	P4	4760	17152	2380	8576	1587	5717
QQ	2755	11021	1378	4103	918	2744	QQ	3662	13195	1831	6429	1221	3731
QR	3131	12523	1565	4611	1044	3102	QR	4097	14763	2048	6163	1366	4152
QS	3360	13441	1680	4913	1120	3318	QS	4545	16377	2272	7762		
Q2	2523	10093	1262	4780	841	3221	Q2	3229	11635	1614	5817	1076	3878
Q3	2960	11842	1480	5503	987	3745	Q3	3917	14114	1958	7057	1306	4705
Q4	3356	13425	1678	6121	1119	4207	Q4	4760	17152	2380	8576		
QT	3602	14410	1801	5225	1201	3544							
QV	4142	16569	2071	5893	1381	4037							
RQ	3770	15080	1885	5689	1257	3737	RQ	4907	17684	2454	8573	1636	4917
RS	4605	18418	2302	6863	1535	4517	RR	5390	19423	2695	9307	1797	5360
RV	5405	21621	2703	7946	1802	5240	RS	5753	20730	2876	8570		
R3	3870	15482	1935	7403	1290	4872	R2	4228	15235	2114	7618	1409	5078
R5	4603	18413	2302	8650	1534	5708	R3	4996	18005	2498	9002	1665	6002
R7	5241	20965	2621	9682	1747	6404	R4	5914	21311	2957	10655		
RP	3103	12411	1551	4722	1034	3098							
RR	3829	15316	1914	5774	1276	3793							
RT	4633	18530	2316	6902	1544	4542							
R2	3800	15198	1900	7278	1267	4789							
R4	4296	17183	2148	8135	1432	5362							
R6	4816	19263	2408	9000	1605	5943							
SQ	3770	15080	1885	5345	1257	3510	SQ	4907	17684	2454	8573	1636	4626
SS	4605	18418	2302	6457	1535	4247	SR	5390	19423	2695	9307	1797	5047
SV	5405	21621	2703	7487	1802	4933	SS	5753	20730	2876	8081		
S3	3870	15482	1935	6975	1290	4588	S2	4228	15235	2114	7618	1409	4993
S5	4603	18413	2302	8166	1534	5384	S3	4996	18005	2498	9002	1665	5832
S7	5241	20965	2621	9157	1747	6050	S4	5914	21311	2957	10192		
							TP	5396	19446	2698	9316	1799	5470
							TQ	5973	21525	2987	10160	1991	6020
							TR	6576	23696	3288	9629	2192	6583
							TS	6929	24969	3464	11474		
							T2	4607	16602	2304	8301	1536	5534
							T3	5710	20578	2855	10289	1903	6859
							T4	6299	22700	3150	11350	2100	7567
							T5	7093	25559	3546	12780		
							VP	5396	19446	2698	7628	1799	5140
							VQ	5973	21525	2987	10160	1991	5660
							VR	6576	23696	3288	11000	2192	6194
							VS	6929	24969	3464	9518		
							V2	4607	16602	2304	8301	1536	5497
							V3	5710	20578	2855	10289	1903	6749
							V4	6299	22700	3150	10725	2100	7395
							V5	7093	25559	3546	12780		
WP	3103	12411	1551	3973	1034	2605	WQ	5368	19343	2684	9274	1789	4591
WR	3829	15316	1914	4871	1276	3197	WR	5891	21230	2946	7456	1964	5020
WT	4633	18530	2316	5842	1544	3840	WS	6415	23117	3207	10780		
W1	3173	12693	1587	5209	1058	3419	W1	4250	15314	2125	7657	1417	4540
W2	3800	15198	1900	6180	1267	4062	W2	5260	18955	2630	8290	1753	5603
W4	4296	17183	2148	6929	1432	4559	W3	6140	22127	3070	11063	2047	6502

Application Data (continued)

TABLE 1 – WATER FLOW RATE LIMITS (GPM) — BASED UPON STANDARD TUBES @ DESIGN FULL LOAD CONDITIONS - cont.

Model	Evaporator						Model	Condenser					
	1 Pass		2 Pass		3 Pass			1 Pass		2 Pass		3 Pass	
	Min	Max	Min	Max	Min	Max		Min	Max	Min	Max	Min	Max
W6	4816	19263	2408	7693	1605	5069	W4	6785	24450	3392	12225		
XQ	4769	19076	2385	7089	1590	4667	XQ	6241	22491	3121	9429	2080	6272
XR	5272	21087	2636	7769	1757	5121	XR	6967	25105	3483	11968	2322	6943
XS	5740	22961	2870	8386	1913	5534	XS	7900	28470	3950	13302		
X2	4769	19074	2384	8923	1590	5891	X2	4969	17905	2484	8952	1656	5968
X3	5637	22549	2819	10296	1879	6820	X3	6487	23378	3244	11689	2162	7793
X4	6281	25125	3141	11250	2094	7470	X4	8099	29185	4049	14593		
ZQ	4769	19076	2385	6671	1590	4390	ZQ	6241	22491	3121	8878	2080	5899
ZR	5272	21087	2636	7318	1757	4820	ZR	6967	25105	3483	11968	2322	6536
ZS	5740	22961	2870	7907	1913	5214	ZS	7900	28470	3950	13302		
Z1	3959	15836	1980	7122	1320	4686	Z1	4138	14912	2069	7435	1379	4914
Z2	4769	19074	2384	8427	1590	5559	Z2	4969	17905	2484	8952	1656	5880
Z3	5637	22549	2819	9748	1879	6450	Z3	6487	23378	3244	11689	2162	7567
Z4	6281	25125	3141	10672	2094	7077	Z4	8099	29185	4049	13715		

TABLE 1A – WATER FLOW RATE LIMITS (L/S) — BASED UPON STANDARD TUBES @ DESIGN FULL LOAD CONDITIONS

Model	Evaporator						Model	Condenser					
	1 Pass		2 Pass		3 Pass			1 Pass		2 Pass		3 Pass	
	Min	Max	Min	Max	Min	Max		Min	Max	Min	Max	Min	Max
AP	21	83	10	37	7	24	AP	30	109	15	54	10	36
AQ	25	102	13	45	8	29	AQ	39	139	19	67	13	46
AR	31	125	16	54	10	35	AR	43	155	21	74	14	51
AS	38	152	19	65	13	41	AS	49	175	24	82		
CP	41	164	20	73	14	48	CP	49	177	25	88	16	58
CQ	46	184	23	81	15	53	CQ	57	204	28	100	19	66
CR	55	218	27	95	18	63	CR	71	255	35	122	24	81
CS	66	263	33	113	22	74	CS	88	318	44	148		
DP	41	164	20	62	14	41	DP	49	177	25	88	16	50
DQ	46	184	23	70	15	46	DQ	57	204	28	87	19	57
DR	55	218	27	82	18	54	DR	71	255	35	122	24	70
DS	66	263	33	98	22	64	DS	88	318	44	148		
EP	54	217	27	97	18	64	EP	71	255	35	127	24	84
EQ	66	264	33	117	22	77	EQ	85	305	42	151	28	100
ER	78	311	39	136	26	90	ER	100	360	50	175	33	117
ES	92	366	46	159	31	105	ES	110	398	55	192	37	128
ET	106	423	53	181	35	120	ET	123	442	61	210		
FQ	66	264	33	100	22	66	FQ	85	305	42	151	28	86
FR	78	311	39	117	26	77	FR	100	360	50	152	33	101
FS	92	366	46	137	31	91	FS	110	398	55	192	37	111
FT	106	423	53	157	35	104	FT	123	442	61	210		
GQ	91	364	46	158	30	105	EV	100	360	50	175	33	117
GR	103	411	51	176	34	117	EW	110	398	55	192	37	128
GS	116	465	58	197	39	131	EX	123	442	61	210		
HQ	91	364	46	136	30	90	FV	100	360	50	152	33	101
HR	103	411	51	153	34	101	FW	110	398	55	192	37	111
HS	116	465	58	171	39	113	FX	123	442	61	210		
JP	97	390	49	173	32	114	JP	100	360	50	175	33	120
JQ	121	484	60	211	40	140	JQ	119	430	60	205	40	142
JR	151	604	76	259	50	173	JR	156	564	78	256	52	183
JS	165	660	83	279	55	188	JS	174	627	87	277		
KP	97	390	49	159	32	105	KP	100	360	50	175	33	110
KQ	121	484	60	195	40	129	KQ	119	430	60	205	40	131
KR	151	604	76	240	50	160	KR	156	564	78	239	52	169
KS	165	660	83	259	55	174	KS	174	627	87	277		
KT	97	390	49	159	32	105							
KV	121	484	60	195	40	129							
KW	151	604	76	240	50	160							
KX	165	660	83	259	55	174							
LQ	121	484	60	182	40	120	LQ	119	430	60	178	40	122
LR	151	604	76	224	50	149	LR	156	564	78	256	52	158
LS	165	660	83	243	55	162	LS	174	627	87	277		
							MP	138	498	69	229	46	151
MQ	153	612	77	246	51	164	MQ	162	584	81	287	54	175
MR	179	714	89	284	60	191	MR	186	670	93	324	62	199
MS	205	819	102	321	68	217	MS	206	744	103	330		
M2	126	506	63	253	42	169	M2	134	484	67	242	45	161
M3	150	599	75	300	50	200	M3	166	600	83	300	55	200
M4	186	744	93	368	62	248	M4	205	738	102	369		
							NP	138	498	69	248	46	141
NQ	153	612	77	230	51	153	NQ	162	584	81	287	54	163
NR	179	714	89	265	60	178	NR	186	670	93	281	62	186
NS	205	819	102	300	68	203	NS	206	744	103	355		
N2	126	506	63	244	42	163	N2	134	484	67	242	45	161
N3	150	599	75	286	50	192	N3	166	600	83	300	55	200
N4	186	744	93	346	62	235	N4	205	738	102	369		

Application Data (continued)

TABLE 1A – WATER FLOW RATE LIMITS (L/S) — BASED UPON STANDARD TUBES @ DESIGN FULL LOAD CONDITIONS - cont.

Model	Evaporator						Model	Condenser					
	1 Pass		2 Pass		3 Pass			1 Pass		2 Pass		3 Pass	
	Min	Max	Min	Max	Min	Max		Min	Max	Min	Max	Min	Max
PQ	174	695	87	277	58	186	PQ	231	832	116	406	77	253
PR	198	790	99	311	66	210	PR	258	931	129	416	86	281
PS	212	848	106	331	71	224	PS	287	1033	143	490		
P2	159	637	80	318	53	212	P2	204	734	102	367	68	245
P3	187	747	93	370	62	249	P3	247	890	124	445	82	297
P4	212	847	106	410	71	282	P4	300	1082	150	541	100	361
QQ	174	695	87	259	58	173	QQ	231	832	116	406	77	235
QR	198	790	99	291	66	196	QR	258	931	129	389	86	262
QS	212	848	106	310	71	209	QS	287	1033	143	490		
Q2	159	637	80	302	53	203	Q2	204	734	102	367	68	245
Q3	187	747	93	347	62	236	Q3	247	890	124	445	82	297
Q4	212	847	106	386	71	265	Q4	300	1082	150	541		
QT	227	909	114	330	76	224							
QV	261	1045	131	372	87	255							
RQ	238	951	119	359	79	236	RQ	310	1116	155	541	103	310
RS	291	1162	145	433	97	285	RR	340	1225	170	587	113	338
RV	341	1364	171	501	114	331	RS	363	1308	181	541		
R3	244	977	122	467	81	307	R2	267	961	133	481	89	320
R5	290	1162	145	546	97	360	R3	315	1136	158	568	105	379
R7	331	1323	165	611	110	404	R4	373	1344	187	672		
RP	196	783	98	298	65	195							
RR	242	966	121	364	81	239							
RT	292	1169	146	435	97	287							
R2	240	959	120	459	80	302							
R4	271	1084	136	513	90	338							
R6	304	1215	152	568	101	375							
SQ	238	951	119	337	79	221	SQ	310	1116	155	541	103	292
SS	291	1162	145	407	97	268	SR	340	1225	170	587	113	318
SV	341	1364	171	472	114	311	SS	363	1308	181	510		
S3	244	977	122	440	81	289	S2	267	961	133	481	89	315
S5	290	1162	145	515	97	340	S3	315	1136	158	568	105	368
S7	331	1323	165	578	110	382	S4	373	1344	187	643		
							TP	340	1227	170	588	113	345
							TQ	377	1358	188	641	126	380
							TR	415	1495	207	607	138	415
							TS	437	1575	219	724		
							T2	291	1047	145	524	97	349
							T3	360	1298	180	649	120	433
							T4	397	1432	199	716	132	477
							T5	447	1613	224	806		
							VP	340	1227	170	481	113	324
							VQ	377	1358	188	641	126	357
							VR	415	1495	207	694	138	391
							VS	437	1575	219	600		
							V2	291	1047	145	524	97	347
							V3	360	1298	180	649	120	426
							V4	397	1432	199	677	132	467
							V5	447	1613	224	806		
WP	196	783	98	251	65	164	WQ	339	1220	169	585	113	290
WR	242	966	121	307	81	202	WR	372	1339	186	470	124	317
WT	292	1169	146	369	97	242	WS	405	1458	202	680		
W1	200	801	100	329	67	216	W1	268	966	134	483	89	286
W2	240	959	120	390	80	256	W2	332	1196	166	523	111	354
W4	271	1084	136	437	90	288	W3	387	1396	194	698	129	410
W6	304	1215	152	485	101	320	W4	428	1543	214	771		

TABLE 1A – WATER FLOW RATE LIMITS (L/S) — BASED UPON STANDARD TUBES @ DESIGN FULL LOAD CONDITIONS - cont.

Model	Evaporator						Model	Condenser					
	1 Pass		2 Pass		3 Pass			1 Pass		2 Pass		3 Pass	
	Min	Max	Min	Max	Min	Max		Min	Max	Min	Max	Min	Max
XQ	301	1204	150	447	100	294	XQ	394	1419	197	595	131	396
XR	333	1330	166	490	111	323	XR	440	1584	220	755	147	438
XS	362	1449	181	529	121	349	XS	498	1796	249	839		
X2	301	1203	150	563	100	372	X2	313	1130	157	565	104	377
X3	356	1423	178	650	119	430	X3	409	1475	205	737	136	492
X4	396	1585	198	710	132	471	X4	511	1841	255	921		
ZQ	301	1204	150	421	100	277	ZQ	394	1419	197	560	131	372
ZR	333	1330	166	462	111	304	ZR	440	1584	220	755	147	412
ZS	362	1449	181	499	121	329	ZS	498	1796	249	839		
Z1	250	999	125	449	83	296	Z1	261	941	131	469	87	310
Z2	301	1203	150	532	100	351	Z2	313	1130	157	565	104	371
Z3	356	1423	178	615	119	407	Z3	409	1475	205	737	136	477
Z4	396	1585	198	673	132	447	Z4	511	1841	255	865		

Application Data (continued)

chilled water and condenser water circuits. The connections (water nozzles) to these circuits are furnished with grooves to ANSI/AWWA C-606 Standard for grooved and shouldered joints. Piping should be arranged for ease of disassembly at the unit for tube cleaning. All water piping should be thoroughly cleaned of all dirt and debris before final connections are made to the chiller.

Chilled Water – A water strainer of maximum 1/8" (3.2 mm) perforated holes must be field-installed in the chilled water inlet line as close as possible to the chiller. If located close enough to the chiller, the chilled water pump may be protected by the same strainer. The strainer is important to protect the chiller from debris or objects which could block flow through individual heat exchanger tubes. A reduction in flow through tubes could seriously impair the chiller performance or even result in tube freeze-up. A thermal-type flow switch is factory installed in the evaporator nozzle and connected to the OptiView panel, which assures adequate chilled water flow during operation.

Condenser Water – The chiller is engineered for maxi-

imum efficiency at both design and part load operation by taking advantage of the colder cooling tower water temperatures which naturally occur during the winter months. Appreciable power savings are realized from these reduced heads.

The minimum entering condenser water temperature for other full and part load conditions is provided by the following equation:

$$\text{Min. ECWT} = \text{LCHWT} - \text{C RANGE} + 5^\circ\text{F} + 12 \left(\frac{\% \text{Load}}{100} \right)$$

$$\text{Min. ECWT} = \text{LCHWT} - \text{C RANGE} + 2.8^\circ\text{C} + 6.6 \left(\frac{\% \text{Load}}{100} \right)$$

where:

- ECWT = entering condensing water temperature
- LCHWT = leaving chilled water temperature
- C RANGE = condensing water temperature range at the given load condition.

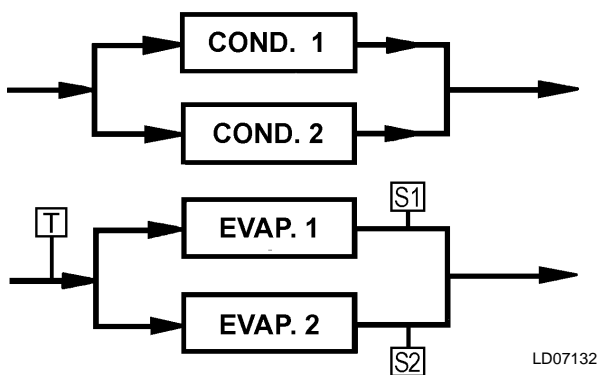

- S** – Temperature Sensor for Chiller Capacity Control
- T** – Thermostat for Chiller Capacity Control

**FIG. 1 – PARALLEL EVAPORATORS
PARALLEL CONDENSERS**

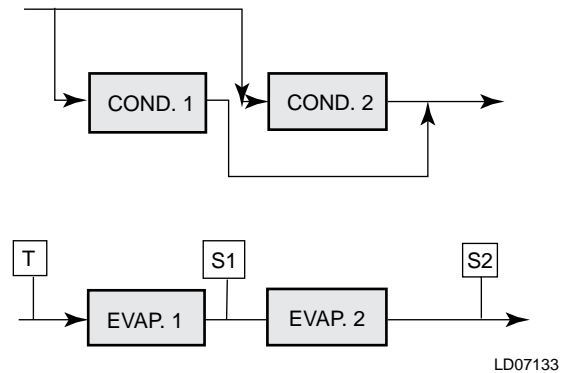

- S** – Temperature Sensor for Chiller Capacity Control
- T** – Thermostat for Chiller Capacity Control

**FIG. 2 – SERIES EVAPORATORS
PARALLEL CONDENSERS**

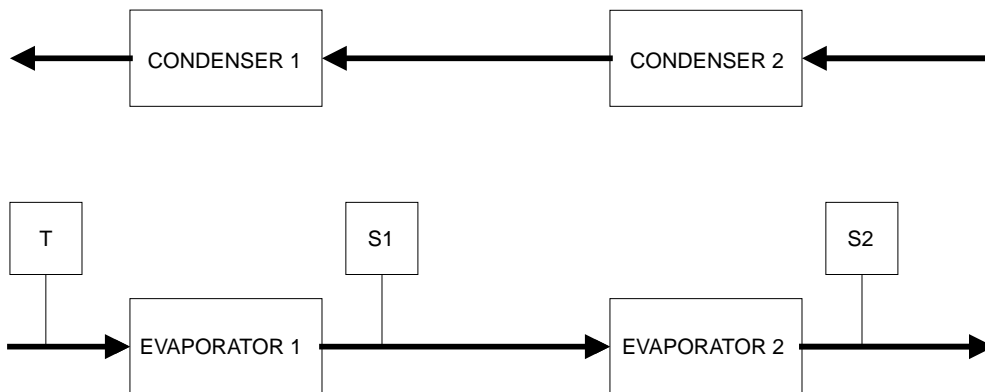

**FIG. 3 – SERIES EVAPORATORS
SERIES-COUNTER FLOW CONDENSERS**

At initial startup, entering condensing water temperature may be as much as 25°F (13.9°C) colder than the standby chilled water temperature.

MULTIPLE UNITS

Selection – Many applications require multiple units to meet the total capacity requirements as well as to provide flexibility and some degree of protection against equipment shutdown. There are several common unit arrangements for this type of application. The MAXE chiller has been designed to be readily adapted to the requirements of these various arrangements.

Parallel Arrangement (Refer to Fig. 1) – Chillers may be applied in multiples with chilled and condenser water circuits connected in parallel between the units. Fig. 1 represents a parallel arrangement with two chillers. Parallel chiller arrangements may consist of equally or unequally sized units. When multiple units are in operation, they will load and unload at equal percentages of design full load for the chiller.

Depending on the number of units and operating characteristics of the units, loading and unloading schemes should be designed to optimize the overall efficiency of the chiller plant. It is recommended to use an evaporator bypass piping arrangement to bypass fluid around evaporator of any unit which has cycled off at reduced load conditions. It is also recommended to alternate the chiller cycling order to equalize chiller starts and run hours.

Series Arrangement (Refer to Fig. 2) – Chillers may be applied in pairs with chilled water circuits connected in series and condenser water circuits connected in parallel. All of the chilled water flows through both evaporators with each unit handling approximately one-half of the total load. When the load decreases to a customer selected load value, one of the units will be shut down by a sequence control. Since all water is flowing through the operating unit, that unit will cool the water to the desired temperature.

Series Counter Flow Arrangement (Refer to Fig. 3) - Chillers may be applied in pairs with chilled water circuits connected in series and with the condenser water in series counter flow. All of the chilled water flows through both evaporators. All of the condenser water flows through both condensers. The water ranges are split, which allows a lower temperature difference or "head" on each chiller, than multiple units in parallel. For equal chillers, the machine at higher temperature level will typically provide slightly more than half the capacity. The compressor motors and gear codes on the two chillers are often matched, such that the high temperature machine can operate at the low temperature conditions when one unit is cycled off at part loads. (as compared to series-parallel chillers which are typically not identical).

Series counter flow application can provide a significant building energy savings for large capacity plants which have chilled and condenser water temperature ranges greater than typical ARI.

REFRIGERANT RELIEF PIPING

Each chiller is equipped with dual pressure relief valves on the condenser and two dual relief valves on the evaporator, or two single relief valves on the evaporator if the optional refrigerant isolation valves are ordered. The dual relief valves on the condenser are redundant and allow changing of either valve while the unit is fully charged. The purpose of the relief valves is to quickly relieve excess pressure of the refrigerant charge to the atmosphere, as a safety precaution in the event of an emergency such as fire. They are set to relieve at an internal pressure as noted on the pressure vessel data plate, and are provided in accordance with ASHRAE 15 safety code and ASME or applicable pressure vessel code.

Sized to the requirements of applicable codes, a vent line must run from the relief device to the outside of the building. This refrigerant relief piping must include a cleanable, vertical-leg dirt trap to catch vent-stack condensation. Vent piping must be arranged to avoid imposing a strain on the relief connection and should include one flexible connection.

SOUND AND VIBRATION CONSIDERATIONS

A MAXE chiller is not a source of objectionable sound and vibration in normal air conditioning applications. Neoprene isolation mounts are furnished as standard with each unit. Optional level-adjusting spring isolator assemblies designed for 1" (25 mm) static deflection are available from YORK.

MAXE chiller sound pressure level ratings will be furnished on request.

Control of sound and vibration transmission must be taken into account in the equipment room construction as well as in the selection and installation of the equipment.

THERMAL INSULATION

No appreciable operating economy can be achieved by thermally insulating the chiller. However, the chiller's cold surfaces should be insulated with a vapor barrier insulation sufficient to prevent condensation. A chiller can be factory-insulated with 3/4" (19 mm) or 1-1/2" (38 mm) thick insulation, as an option. This insulation will normally prevent condensation in environments with dry bulb temperatures of 50°F to 90°F (10°C to 32°C) and relative humidities up to 75% [3/4" (19 mm) thickness] or 90% [1-1/2" (38 mm) thickness]. The insulation is painted and

Application Data (continued)

the surface is flexible and reasonably resistant to wear. It is intended for a chiller installed indoors and, therefore, no protective covering of the insulation is usually required. If insulation is applied to the water boxes at the job site, it must be removable to permit access to the tubes for routine maintenance.

VENTILATION

The ASHRAE Standard 15 Safety Code for Mechanical Refrigeration requires that all machinery rooms be vented to the outdoors utilizing mechanical ventilation by one or more power-driven fans. This standard, plus National Fire Protection Association Standard 90A, state, local and any other related codes should be reviewed for specific requirements. Since the MAXE chiller motor is air-cooled, ventilation should allow for the removal of heat from the motor.

In addition, the ASHRAE Standard 15 requires a refrigerant vapor detector to be employed for all refrigerants. It is to be located in an area where refrigerant from a leak would be likely to concentrate. An alarm is to be activated and the mechanical ventilation started at a value no greater than the TLV (Threshold Limit Value) of the refrigerant.

ELECTRICAL CONSIDERATIONS

Motor Voltage – Low voltage motors (200 to 600 volts) are furnished with six leads. Medium voltage (2300 to 4160 volts) motors have three leads. Motor circuit conductor size must be in accordance with the National Electrical Code (N.E.C.), or other applicable codes, for the motor full load amperes (FLA). Flexible conduit should be used for the last several feet to the chiller in order to provide

vibration isolation. Table 2 lists the allowable variation in voltage supplied to the chiller motor. The unit name plate is stamped with the specific motor voltage, and frequency for the appropriate motor.

Starters – A separate starter is not required if the chiller is equipped with a Variable Speed Drive (VSD). The MAXE chillers are also available with a factory-mounted and wired YORK Solid State Starter for low voltage applications. Other types of remote mounted starters are available. Electro-mechanical starters must be furnished in accordance with YORK Standard Specifications (R-1132). This will ensure that starter components, controls, circuits, and terminal markings will be suitable for required overall system performance. Remote-mounted medium voltage York Solid State Starters are also available.

Controls – A 115 volt, single-phase, 60 or 50 Hertz 2 KVA power supply must be furnished to the chiller from a separate, fused disconnect or from a control transformer included as an option with electro-mechanical starters. No field control wiring is required when the low voltage YORK Variable Speed Drive or Solid State Starter is supplied.

Oil Pump Power Supply – A separate 3-phase power supply with a fused disconnect for the factory-mounted oil pump variable speed drive is required unless the low voltage VSD or SSS is supplied. Power can also be supplied through an electro-mechanical starter, remote mounted Medium Voltage Solid State Starter (MVSSS) or Medium Voltage Variable Speed Drive (MVVSD).

Copper Conductors – *Only copper conductors should be connected to compressor motors and starters.* Aluminum conductors have proven to be unsatisfactory when connected to copper lugs. Aluminum oxide and the difference in thermal conductivity between copper and aluminum cannot guarantee the required tight connection over a long period of time.

Power Factor Correction Capacitors – When the chiller is equipped with a VSD, automatic power factor correction to a minimum of 0.95 is provided at all operating conditions, so additional capacitors are not required. For other starting methods, capacitors can be applied to a chiller for the purpose of power factor correction. For remote-mounted electro-mechanical starters, the capacitors should be located on the load-side of the starter. For YORK Solid State Starters the capacitors must be located on the line-side of the starter. The capacitors must be sized and installed to meet the National Electrical Code and be verified by YORK.

Ampacity on Load Side of Starter – Electrical power wire size to the chiller is based on the minimum unit ampacity. For Solid State Starters or Variable Speed Drive, this wiring is done at the factory. For remote starters, the National Electrical Code defines the calculation of ampacity.

TABLE 2 – MOTOR VOLTAGE VARIATIONS

FREQ.	RATED VOLTAGE	NAMEPLATE VOLTAGE	OPERATING VOLTAGE	
			MIN.	MAX.
60 HZ	200	200/208	180	220
	230	220/240	208	254
	380	380	342	415
	416	416	375	457
	460	440/460/480	414	508
	575	575/600	520	635
	2300	2300	2070	2530
	3300	3300	2970	3630
	4000	4000/4160	3600	4576
50 HZ	346	346	311	381
	380	380/400	342	423
	415	415	374	440
	3300	3300	2970	3630

ity, as summarized below. More specific information on actual amperage ratings will be supplied with the submittal drawings.

- Six-lead type of starting (Star-Delta)
 - Minimum circuit ampacity per conductor (1 of 6):
 - Ampacity = .721 x compressor motor amps.
- Three-lead type of starting
 - (Across-the-Line, Autotransformer and Primary Reactor)
 - Minimum circuit ampacity per conductor (1 of 3):
 - Ampacity = 1.25 x compressor motor amps.

Ampacity on Line-Side of Starter – The only additional load on the circuit for the chiller would be the control transformer and oil pump motor unless they are supplied by a separate source.

Minimum Circuit Ampacity = 125% of compressor motor amps + FLA of all other loads on the circuit.

Branch Circuit Overcurrent Protection – The branch circuit overcurrent protection device(s) should be a time-delay type, with a minimum rating equal to the next standard fuse/breaker rating above the calculated value. It is calculated taking into account the compressor motor amps and may also include control transformer and oil

pump motor. Refer to submittal drawings for the specific calculations for each application.

MOTOR ELECTRICAL DATA

The smallest motor available which equals or exceeds the Input power (kW) from the chiller rating program is selected from Tables 3 and 4. The full load amperes (FLA) listed in the tables are maximum values and correspond to the maximum motor kW listed. When the input power (kW) is less than maximum motor kW, the FLA should be reduced per the following equation:

$$\text{FLA} = \frac{\text{Motor kW}}{\text{Max. Motor kW}} \times \text{Max. Motor FLA}$$

The benefit from the FLA correction is the possible use of smaller power wiring and/or starter size.

The locked rotor amperes (LRA) are read directly from Tables 3 and 4 for specific Motor Code and voltage. This is because the LRA is dependent only on motor size and voltage and is independent of input power (kW).

Inrush amperes (IRA) depend on LRA and the type of starter applied. The inrush can be calculated using a percentage of LRA shown in Table 3.

Application Data (continued)

TABLE 3 – 60 Hz ELECTRICAL DATA

MOTOR CODE	CF	CG	CH	CJ	CK	CL	CM	CN	CP	CR	CS	CT	CU	CV	CW
KW (MAX)	125	144	161	190	214	240	257	276	302	333	368	395	435	478	514
SHAFT HPFL.	154	177	201	237	270	302	327	351	385	424	468	503	554	608	655
EFF. - %	92	92	93	93	94	94	95	95	95	95	95	95	95	95	95
VOLTS	AMPERES (MAX.)														
200	FLA	405	465	527	618	707	787	921	1,014	1,085	1,208	—	—	—	—
	LRA	2,598	3,111	3,810	4,550	4,900	5,470	5,780	7,350	7,794	—	—	—	—	—
208	FLA	389	447	507	594	680	757	799	886	975	1,043	1,162	—	—	—
	LRA	2,702	3,235	3,235	3,962	4,732	5,096	5,689	6,011	6,011	7,644	8,106	—	—	—
230	FLA	352	404	464	540	610	685	749	804	882	944	1,050	1,130	—	—
	LRA	2,598	2,598	2,865	3,460	3,788	4,260	4,755	5,162	5,780	5,780	6,900	7,400	—	—
240	FLA	337	387	445	518	585	656	718	771	845	905	1,006	1,083	—	—
	LRA	2,711	2,711	3,120	3,610	3,953	4,445	4,962	5,386	6,031	6,031	7,200	7,722	—	—
380	FLA	217	249	285	336	378	421	453	487	534	571	636	684	756	817
	LRA	1,385	1,385	1,730	2,153	2,500	2,577	2,955	3,254	3,637	3,810	4,179	4,480	4,671	5,326
416	FLA	199	228	260	307	346	385	412	445	488	522	581	625	691	747
	LRA	1,385	1,385	1,638	1,967	2,190	2,356	2,700	2,976	3,536	3,637	3,810	3,810	4,270	4,869
440	FLA	184	211	238	281	319	358	392	397	461	493	549	591	646	706
	LRA	1,177	1,301	1,320	1,655	1,865	2,037	2,485	2,485	2,976	2,976	3,300	3,644	3,644	4,209
460	FLA	176	202	228	269	305	342	375	380	441	472	525	565	618	675
	LRA	1,230	1,360	1,380	1,730	1,950	2,130	2,598	2,598	3,111	3,111	3,450	3,810	3,810	4,400
480	FLA	169	194	219	258	292	328	359	364	423	452	503	541	592	647
	LRA	1,283	1,419	1,440	1,805	2,053	2,223	2,711	2,711	3,246	3,246	3,600	3,976	3,976	4,591
575	FLA	141	162	185	216	250	247	300	318	353	377	420	452	500	540
	LRA	909	909	1,100	1,384	1,556	1,700	1,900	2,066	2,078	2,413	2,760	2,960	3,089	3,550
600	FLA	135	155	177	207	240	263	288	305	338	361	403	433	479	518
	LRA	949	949	1,148	1,444	1,624	1,774	1,983	2,156	2,168	2,518	2,880	3,089	3,223	3,704
2300	FLA	36	41	46	55	63	70	74	80	87	95	106	113	124	
	LRA	240	267	298	340	397	435	480	520	530	590	669	719	791	
3300	FLA	25	29	33	39	44	49	52	55	61	67	73	79	86	
	LRA	160	175	210	240	280	310	310	343	382	415	466	501	551	
4000	FLA	21	24	27	32	36	40	43	46	50	55	60	65	71	
	LRA	135	154	166	195	230	240	270	283	315	340	384	413	455	
4160	FLA	20	23	26	30	34	38	41	44	48	52	58	63	68	
	LRA	140	160	173	203	239	250	270	294	328	328	399	430	473	

TABLE 4 – 50 Hz ELECTRICAL DATA¹

MOTOR CODE	5CC	5CD	5CE	5CF	5CG	5CH	5CI	5CJ	5CK	5CL	5CM	5CN	5CO	5CP	5CQ	5CR	5CS
KW (MAX) SHAFT HPFL EFF.-%FL PF	121	136	160	180	201	215	231	254	280	309	332	366	402	432	455	481	518
	148	168	198	225	252	272	292	321	353	390	419	462	507	546	575	608	658
	91.1	92.4	92.4	93.4	93.4	94.2	94.2	94.2	94.2	94.2	94.2	94.2	94.2	94.2	94.2	94.2	94.7
	0.86	0.86	0.86	0.86	0.86	0.86	0.86	0.86	0.87	0.87	0.87	0.87	0.87	0.87	0.87	0.87	0.88
VOLTS	AMPERES (MAX.)																
346	FLA	224	258	302	340	380	417	437	481	528	584	630	692	578	816	860	909
	LRA	1,385	1,721	1,790	2,208	2,467	2,598	2,840	3,081	3,350	3,706	3,810	4,177	4,830	4,944	5,373	5,780
380	FLA	204	235	275	309	346	379	398	438	481	532	572	630	690	743	783	841
	LRA	1,385	1,385	1,640	1,890	2,144	2,464	2,590	2,806	3,050	3,375	3,700	3,810	4,400	4,500	4,892	5,600
400	FLA	194	223	261	294	329	360	378	416	457	505	543	599	656	706	744	799
	LRA	1,458	1,458	1,726	1,990	2,257	2,594	2,726	2,954	3,211	3,553	3,895	4,011	4,632	4,737	5,149	5,895
415	FLA	187	215	252	284	317	347	364	401	441	487	526	577	632	680	717	764
	LRA	1,283	1,385	1,490	1,700	2,031	2,175	2,366	2,569	2,794	3,088	3,402	3,478	3,810	4,117	4,480	5,130
3300	FLA	24	27	32	36	41	44	47	50	56	62	66	73	80	87	91	103
	LRA	159	162	209	236	241	274	294	318	317	388	423	455	499	516	572	614

NOTE: 1. Chiller performance for 50 Hertz applications is outside the scope of the ARI Certification Program.

CX	CY	CZ	CA	CB	DA	DB	DC	DD	DE	DF	DH	DJ	DK	DL	MOTOR CODE	
542	578	617	660	703	781	859	937	1,015	1,093	1,171	1,359	1,554	1,748	1,942	KW (MAX.) SHAFT HP EFF.-%**	
690	740	790	845	900	1,000	1,100	1,200	1,300	1,400	1,500	1,750	2,000	2,250	2,500		
95	95.5	95.5	95.5	95.5	95.5	95.5	95.5	95.5	95.5	95.5	96	96	96	96		
AMPERES (MAX.)															VOLTS	
—	—	—	—	—	—	—	—	—	—	—	—	—	—	—	FLA	200
—	—	—	—	—	—	—	—	—	—	—	—	—	—	—	LRA	
—	—	—	—	—	—	—	—	—	—	—	—	—	—	—	FLA	208
—	—	—	—	—	—	—	—	—	—	—	—	—	—	—	LRA	
—	—	—	—	—	—	—	—	—	—	—	—	—	—	—	FLA	230
—	—	—	—	—	—	—	—	—	—	—	—	—	—	—	LRA	
—	—	—	—	—	—	—	—	—	—	—	—	—	—	—	FLA	240
—	—	—	—	—	—	—	—	—	—	—	—	—	—	—	LRA	
942	997	1065	1,126	1,200	1,364	1,500	1,636	—	—	—	—	—	—	—	FLA	380
6,782	5,780	6,644	7,106	7,513	7,794	8,491	9,431	—	—	—	—	—	—	—	LRA	
860	911	973	1,029	1,096	1,246	1,370	1,495	—	—	—	—	—	—	—	FLA	416
5,780	5,694	6,069	6,489	6,863	7,120	7,755	8,608	—	—	—	—	—	—	—	LRA	
813	861	920	973	1,036	1,178	1,295	1,413	—	—	—	—	—	—	—	FLA	440
5,357	4,783	5,249	5,529	5,529	6,160	6,709	7,455	—	—	—	—	—	—	—	LRA	
778	824	880	931	991	1,127	1,239	1,352	—	—	—	—	—	—	—	FLA	460
5,600	5,000	5,488	5,780	5,780	6,440	7,014	7,794	—	—	—	—	—	—	—	LRA	
746	790	843	892	950	1,080	1,187	1,296	—	—	—	—	—	—	—	FLA	480
5,843	5,217	5,727	6,031	6,031	6,720	7,319	8,133	—	—	—	—	—	—	—	LRA	
622	659	704	744	793	901	991	1,081	—	—	—	—	—	—	—	FLA	575
4,440	4,300	4,200	4,694	4,963	5,148	5,610	6,232	—	—	—	—	—	—	—	LRA	
596	632	675	713	760	863	950	1,036	—	—	—	—	—	—	—	FLA	600
4,633	4,484	4,383	4,898	5,179	5,372	5,854	6,503	—	—	—	—	—	—	—	LRA	
154	165	176	186	198	225	248	267	290	312	334	389	438	493	548	FLA	2,300
960	1,008	1,100	1,172	1,230	1,234	1,592	1,592	1,592	2,031	2,031	2,390	2,879	2,908	3,012	LRA	
108	115	123	130	138	157	173	186	202	217	233	271	306	344	382	FLA	3,300
682	719	744	744	858	861	1,110	1,110	1,110	1,416	1,416	1,661	2,011	2,027	2,100	LRA	
89	95	101	107	114	130	143	154	166	179	192	224	252	283	315	FLA	4,000
540	554	631	674	713	715	923	923	923	1,177	1,177	1,386	1,669	1,672	1,732	LRA	
85	91	97	103	110	125	137	149	160	172	185	215	242	273	303	FLA	4,160
562	576	656	701	742	744	960	960	960	1,224	1,224	1,441	1,736	1,608	1,666	LRA	

5CT	5CU	5CV	5CW	5CX	5DA	5DB	5DC	5DD	5DE	5DF	5DG	5DH	*5DJ	5DK	5DL	MOTOR code	
554	591	630	669	709	785	863	942	1,015	1,093	1,171	1,288	1,360	1,554	1,748	1,942	KW(MAX.) SHAFT HP FL EFF.-%** FL PF**	
704	750	800	850	900	1,000	1,100	1,200	1,300	1,400	1,500	1,650	1,750	2,000	2,250	2,500		
94.7	94.7	94.7	94.7	94.7	95	95	95	95.5	95.5	95.5	95.5	96	96	96	96		
0.88	0.89	0.89	0.89	0.89	0.88	0.87	0.88	0.88	0.88	0.88	0.88	0.89	0.89	0.89	0.89		
AMPERES (MAX.)															VOLTS		
1,051	1,107	1,181	1,255	1,329	1,488	1,656	—	—	—	—	—	—	—	—	—	FLA	346
6,615	6,931	7,356	7,794	8,319	8,559	9,346	—	—	—	—	—	—	—	—	—	LRA	
957	1,008	1,075	1,143	1,210	1,355	1,508	—	—	—	—	—	—	—	—	—	FLA	380
5,491	6,313	6,694	7,113	7,404	7,794	8,511	—	—	—	—	—	—	—	—	—	LRA	
909	958	1,021	1,086	1,150	1,287	1,433	—	—	—	—	—	—	—	—	—	FLA	400
5,780	6,645	7,046	7,487	7,794	8,204	8,959	—	—	—	—	—	—	—	—	—	LRA	
876	923	985	1,046	1,108	1,241	1,381	—	—	—	—	—	—	—	—	—	FLA	415
5,512	5,780	6,131	6,513	6,938	7,138	7,794	—	—	—	—	—	—	—	—	—	LRA	
110	116	124	132	139	156	174	187	202	217	233	256	267	306	344	382	FLA	3,300
693	725	744	819	875	871	1,135	1,135	1,135	1,415	1,415	1,415	1,667	1,591	2,231	2,481	LRA	

*Min. reduced voltage tap 80%.

** High voltage and special motor designs may not meet efficiency and P. F. shown for standard motors

Application Data (continued)

TABLE 5 – MOTOR STARTERS

TYPE STARTER	SOLID STATES TARTER	STAR DELTA	AUTO TRANSFORMER			ACROSS-THE-LINE	PRIMARY REACTOR	
			LOW	LOW/MEDIUM	LOW/MEDIUM		LOW/MEDIUM	MEDIUM
VOLTAGE 60 HZ	LOW/MEDIUM	LOW	LOW	LOW/MEDIUM	LOW/MEDIUM	LOW/MEDIUM	MEDIUM	MEDIUM
	200-4160	200-600	200-600	200-4160	200-4160	200-4160	2300-4160	2300-4160
50 HZ	380-3300	346-415	346-415	346-3300	346-3300	346-3300	2300-3300	2300-3300
TRANSITION % TAP INRUSHAS A % OF LRA	—	CLOSED	CLOSED	CLOSED	CLOSED	—	CLOSED	CLOSED
	—	—	57.7	65	80	—	65	80
	45	33	33	42.3	64	100	65	80

NOTE: Inrush less than 100% of full load amps (FLA).

TABLE 6 – AVAILABLE COMPRESSOR/SHELL/MOTOR COMBINATIONS

YK Mod G Combinations

Compressor Codes	Evaporator Codes	Condenser Codes	Motor Codes	
			60 Hz	50 Hz
Q3	AP to AS	AP to AS	CF-CT	5CC-5CO
Q3, Q4	CP to CS	CP to CS		
	DP to DS	DP to DS		
Q4	EP to ET	EP to ET		
Q5	CP to CS	CP to CS	CH-CT	5CE-5CO
	DP to DS	DP to DS		
Q5, Q6, Q7, P7	EP to ET	EP to ET		
Q5, Q6, Q7, P7	FQ to FT	FQ to FT	CU-CY	5CP-5CU
P8	GQ to GS	EV to EX	CH-CZ	5CE-5CU
P8, P9	HQ to HS	FV to FX		
	JP to JS	JP to JS		
	LQ to LS	LQ to LS		
H9	KP to KS, K2 to K4	KP to KS, K2 to K4	CN-CA	5CK-5CW
	MQ to MS, M2 to M4	MP to MS, M2 to M4		
K1, K2	KT to KX, K5 to K7	KP to KS, K5 to K7	CW-DC	5CS-5DC
	MQ to MS, M2 to M4	MP to MS, M2 to M4		
	NQ to NS, N2 to N4	NP to NS, N2 to N4		
	PQ to PS, P2 to P4	PQ to PS, P2 to P4		
	QQ to QS, Q2 to Q4	QQ to QS, Q2 to Q4		
K3	NQ to NS, N2 to N4	NP to NS, N2 to N4	DA-DJ	5DA-5DH
	QQ to QV, Q2 to Q4	QQ to QS, Q2 to Q4		
	RQ, RS, RV, R3, R5, R7	RQ to RS, R2 to R4		
K4	RP, RR, RT, R2, R4, R6	RQ to RS, R2 to R4	DA-DJ	5DA-5DJ
	SQ, SS, SV, S3, S5, S7	SQ to SS, S2 to S4		
		VP to VS, V2 to V5		
	XQ to XS, X2 to X4	TP to TS, T2 to T5		
K7	WP-WT, W1, W2, W4, W6	WQ to WS, W1 to W4	DD-DL	5DD-5DL
	ZQ to ZS, Z1 to Z4	ZQ to Zs, Z1 to Z4		

Dimensions (Ft. - In.) – Unit

P & Q COMPRESSOR UNITS

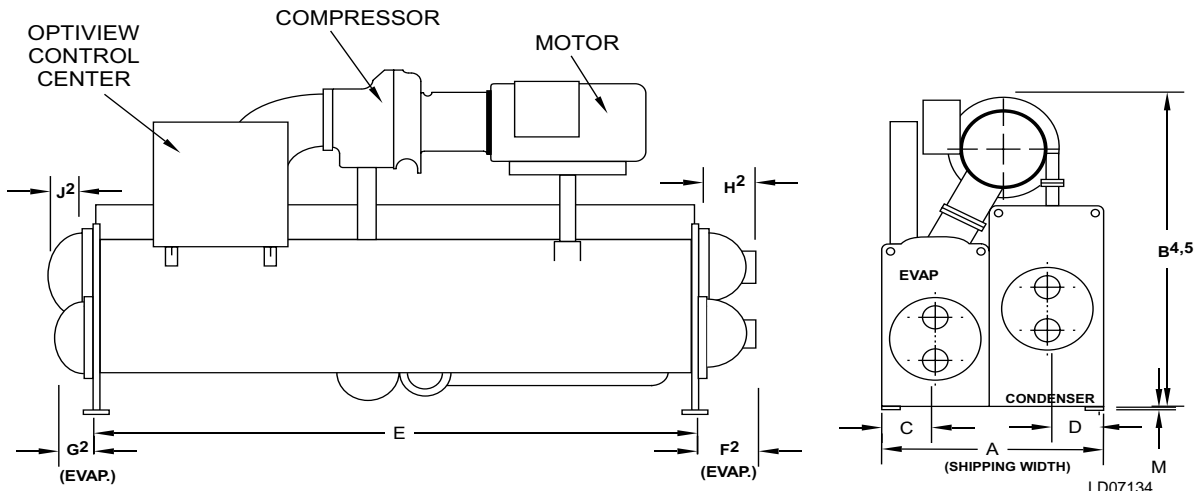

ADDITIONAL OPERATING HEIGHT CLEARANCE TO FLOOR	
TYPE OF CHILLER MOUNTING	M
NEOPRENE PAD ISOLATORS	1-3/4"
SPRING ISOLATORS 1" DEFLECTION	1"
DIRECT MOUNT	3/4"

Q3 COMPRESSOR			
EVAPORATOR-CONDENSER SHELL CODES			
	A-A	C-C	D-D
A	5'-1"	5'-6"	5'-6"
B	7'-0"	7'-3 3/4"	7'-3 3/4"
C	1'-3 1/2"	1'-5 1/2"	1'-5 1/2"
D	1'-3"	1'-3 1/2"	1'-3 1/2"
E	12'-0"	12'-0"	16'-0"

P7, Q7 COMPRESSOR		
EVAPORATOR - CONDENSER SHELL CODES		
	E-E	F-F
A	6'-2"	6'-2"
B	7'-6 1/2"	7'-6 1/2"
C	1'-7 1/2"	1'-7 1/2"
D	1'-5 1/2"	1'-5 1/2"
E	12'-0"	16'-0"

Q4 COMPRESSOR			
EVAPORATOR-CONDENSER SHELL CODE			
	C-C	D-D	E-E
A	5'-6"	5'-6"	7'-0"
B	7'-2 1/2"	7'-2 1/2"	7'-8 1/2"
C	1'-5 1/2"	1'-5 1/2"	1'-7 1/2"
D	1'-3 1/2"	1'-3 1/2"	1'-5 1/2"
E	12'-0"	16'-0"	12'-0"

P8 COMPRESSOR				
EVAPORATOR - CONDENSER SHELL CODES				
	G-E	H-F	J-J	L-L
A	6'-11"	6'-11"	7'-6 1/2"	7'-6 1/2"
B	10'-3 1/2"	10'-3 1/2"	10'-9 1/2"	10'-9 1/2"
C	2'-0"	2'-0"	2'-1 1/4"	2'-1 1/4"
D	1'-5 1/2"	1'-5 1/2"	1'-8"	1'-8"
E	12'-0"	16'-0"	12'-0"	16'-0"

Q5 COMPRESSOR				
EVAPORATOR-CONDENSER SHELL CODES				
	C-C	D-D	E-E	F-F
A	5'-6"	5'-6"	7'-0"	7'-0"
B	7'-10 5/8"	7'-10 5/8"	8'-3"	8'-3"
C	1'-5 1/2"	1'-5 1/2"	1'-7 1/2"	1'-7 1/2"
D	1'-3 1/2"	1'-3 1/2"	1'-5 1/2"	1'-5 1/2"
E	12'-0"	16'-0"	12'-0"	16'-0"

P9 COMPRESSOR			
EVAPORATOR - CONDENSER SHELL CODES			
	H-F	J-J	L-L
A	6'-11"	7'-6 1/2"	7'-6 1/2"
B	9'-11 7/8"	10'-6"	10'-6"
C	2'-0"	2'-1 1/4"	2'-1 1/4"
D	1'-5 1/2"	1'-8"	1'-8"
E	16'-0"	12'-0"	16'-0"

Q6 COMPRESSOR		
EVAPORATOR-CONDENSER SHELL CODES		
	E-E	F-F
A	7'-0"	7'-0"
B	8'-3"	8'-3"
C	1'-7 1/2"	1'-7 1/2"
D	1'-5 1/2"	1'-5 1/2"
E	12'-0"	16'-0"

Dimensions (Ft. - In.) – Unit

H COMPRESSOR UNITS

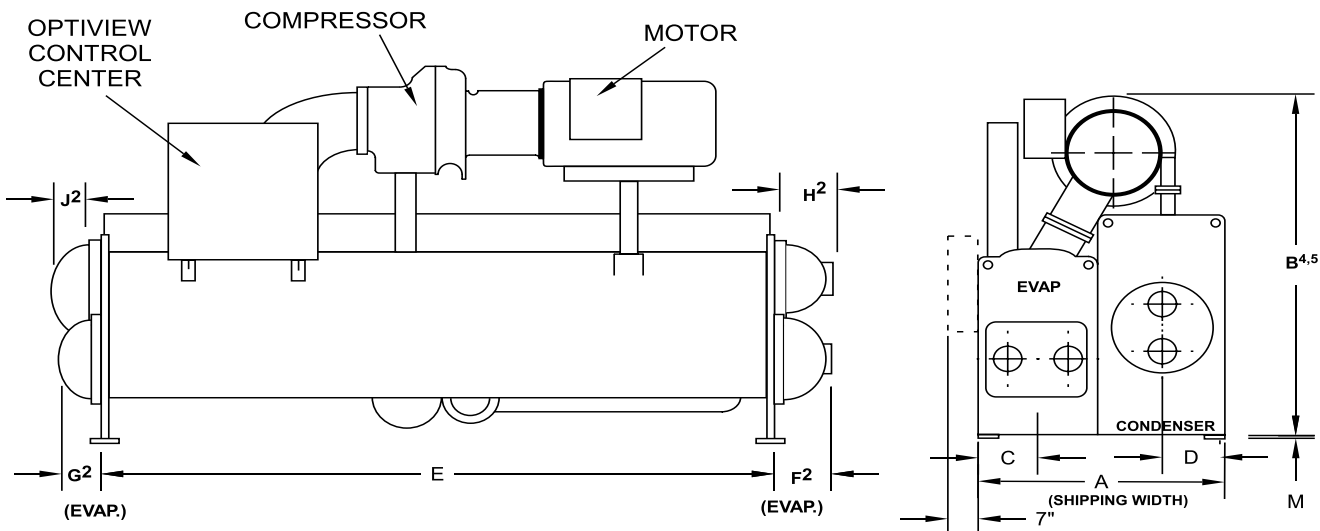

LD07135

ADDITIONAL OPERATING HEIGHT CLEARANCE TO FLOOR	
TYPE OF CHILLER MOUNTING	M
NEOPRENE PAD ISOLATORS	1 3/4"
SPRING ISOLATORS 1" DEFLECTION	1"
DIRECT MOUNT	3/4"

H9 COMPRESSORS		
EVAP. – COND. SHELL CODES		
	K-K	M-M
A	7'-6 1/2"	9'-0"
B	9'-5"	10'-2"
C	2'-1 1/4"	2'-4 1/2"
D	1'-8"	1'-11"
E	14'-0"	14'-0"

NOTES:

1. All dimensions are approximate. Certified dimensions are available on request.
2. For all water boxes (compact shown above), determine overall unit length by adding water box depth to tube sheet length.
3. Water nozzles can be located on either end of unit. Add 1/2" to nozzle length for flanged connections.
4. To determine overall height, add dimension "M" for the appropriate isolator type.
5. Use of motors with motor hoods may increase overall unit dimensions.

Dimensions (Ft. - In.) – Unit

K COMPRESSOR UNITS

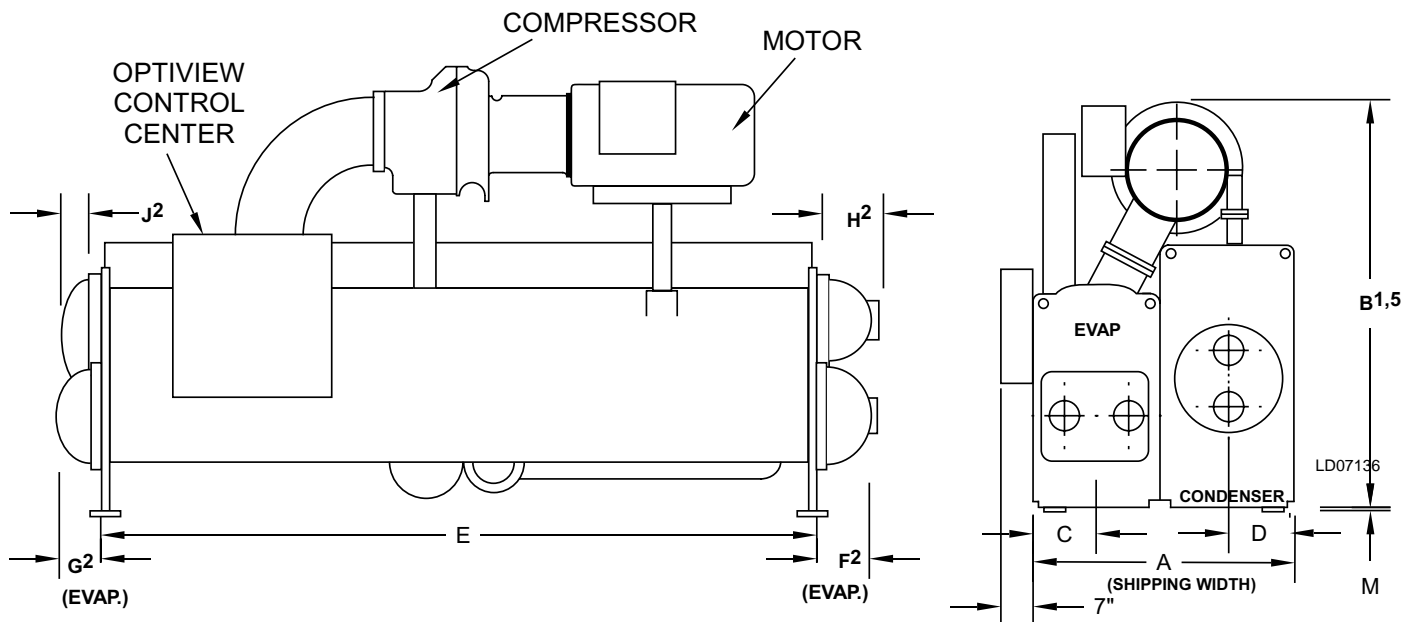

K1 Compressor, Evaporator-Condenser Shell Codes

	K-K	M-M	N-N	P-P	Q-Q
A	7'-6 1/2"	8'-7"	8'-7"	9'-1 1/2"	9'-1 1/2"
B		11'-4"	11'-4"	11'-5 1/2"	11'-5 1/2"
C	2'-1 1/4"	2'-4 1/2"	2'-4 1/2"	2'-5 1/2"	2'-5 1/2"
D	1'-8"	1'-11"	1'-11"	2'-1 1/4"	2'-1 1/4"
E	14'-0"	14'-0"	16'-0"	14'-0"	16'-0"

K2 Compr., Evaporator-Condenser Shell Codes

	M-M	N-N	P-P	Q-Q
A	8'-7"	8'-7"	9'-1 1/2"	9'-1 1/2"
B	11'-4"	11'-4"	11'-5"	11'-5"
C	2'-4 1/2"	2'-4 1/2"	2'-5 1/2"	2'-5 1/2"
D	1'-11"	1'-11"	2'-1 1/4"	2'-1 1/4"
E	14'-0"	16'-0"	14'-0"	16'-0"

K4 Compressor, Evaporator-Condenser Shell Codes

	R-R	S-S	S-V	X-T	X-X
A	9'-9"	9'-9"	10'-3"	10'-10"	11'-3"
B					
C	2'-8"	2'-8"	2'-8"	2'-11 1/2"	2'-11 1/2"
D	2'-3 1/2"	2'-3 1/2"	2'-5 1/2"	2'-5 1/2"	2'-8"
E	16'-0"	18'-0"	18'-0"	16'-0"	16'-0"

Additional Operating Height Clearance

Type of Chiller Mounting	M
Neoprene Pad Isolators	1 3/4"
Spring Isolators 1" Deflection	1"
Direct Mount	3/4"

K3 Compr., Evap.-Cond. Shell Codes

	N-N	Q-Q	R-R
A	8'-7"	9'-1 1/2"	9'-9"
B		11'-6"	11'-10"
C	2'-4 1/2"	2'-5 1/2"	2'-8"
D	1'-11"	2'-1 1/4"	2'-3 1/2"
E	16'-0"	16'-0"	16'-0"

K7 Compr., Evap.-Cond Shell Codes

	W-W	Z-Z
A	10'-3"	11'-3"
B	12'-2"	12'-10"
C	2'-8"	2'-11 1/2"
D	2'-5 1/2"	2'-8"
E	22'-0"	18'-0"

NOTES:

1. All dimensions are approximate. Certified dimensions are available on request.
2. For all water boxes (compact boxes shown above), determine overall unit length by adding water box depth to tube sheet length.
3. Water nozzles can be located on either end of unit. Add 1/2" to nozzle length for flanges connections.
4. To determine overall height, add dimension "M" for the appropriate isolator type.
5. Use of motors with motor hoods may increase overall unit dimensions.
6. Tubesheets are provided with jacking point notches on the P and larger shells.

Dimensions (Ft. - In.) – Nozzle Arrangements

EVAPORATORS – COMPACT WATER BOXES – A THRU K EVAPORATORS

1-PASS

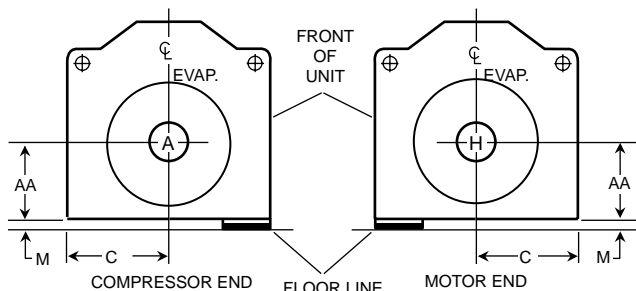

NOZZLE ARRANGEMENTS		
NO. OF PASSES	EVAPORATOR	
	IN	OUT
1	A	H
	H	A

2-PASS

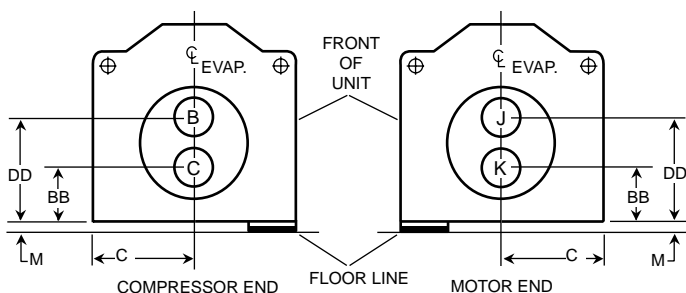

NOZZLE ARRANGEMENTS		
NO. OF PASSES	EVAPORATOR	
	IN	OUT
2	C	B
	K	J

3-PASS

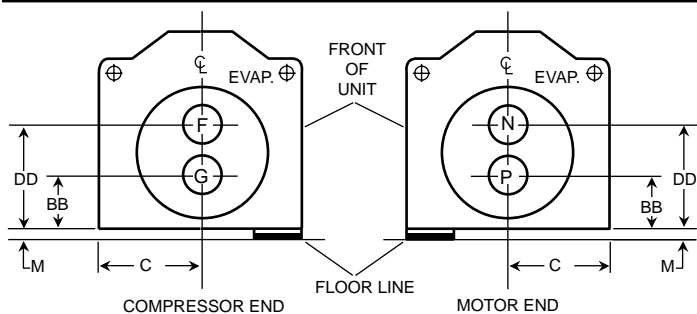

NOZZLE ARRANGEMENTS		
NO. OF PASSES	EVAPORATOR	
	IN	OUT
3	G	N
	P	F

COMPACT WATER BOXES - 150 PSI ROUND

CONDENSER SHELL CODE	NOZZLE PIPE SIZE (IN)			EVAPORATOR NOZZLE DIMENSIONS (FT-IN.)							
	NO. OF PASSES			C	1-PASS			2-PASS		3-PASS	
	1	2	3		AA ⁵	BB ⁵	DD ⁵	BB ⁵	DD ⁵		
A	8	6	4	1'-3 1/2"	1'-10"	1'-2"	2'-6"	1'-2"	2'-6"		
C,D	10	8	6	1'-5 1/2"	2'-0"	1'-3"	2'-9"	1'-3"	2'-9"		
E,F	14	10	8	1'-7"	2'-2"	1'-4"	3'-0"	1'-4"	3'-0"		
G,H	14	10	8	2'-0"	2'-3 1/2"	1'-4"	3'-3"	1'-4"	3'-3"		
J,K,L	16	12	10	2'-1 1/4"	2'-6"	1'-4 1/2"	3'-7 1/2"	1'-5"	3'-7"		

See Notes on pg 41.

EVAPORATORS – COMPACT WATER BOXES – M THRU Z EVAPORATORS

1-PASS

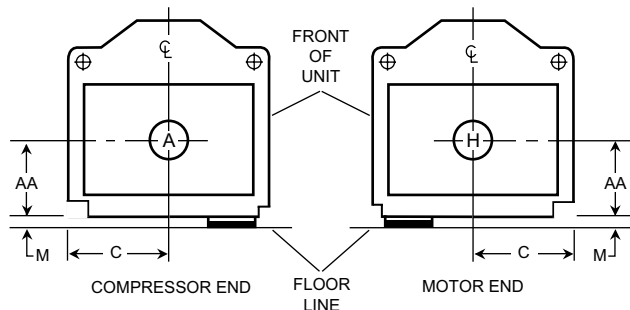

SHELL CODE	1 PASS	
	IN	OUT
M-Z	A	H
	H	A

2-PASS

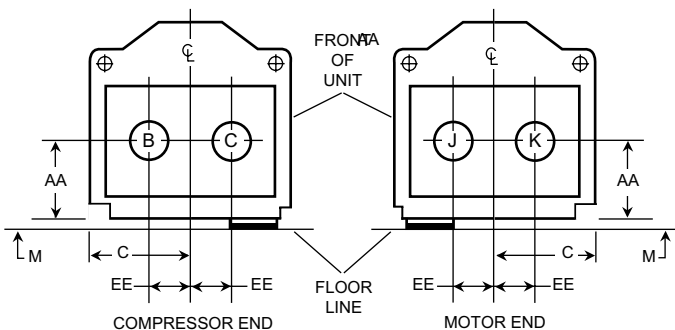

SHELL CODES	2 PASS	
	IN	OUT
M-Z	B	C
	C	B
	J	K
	K	J

3-PASS

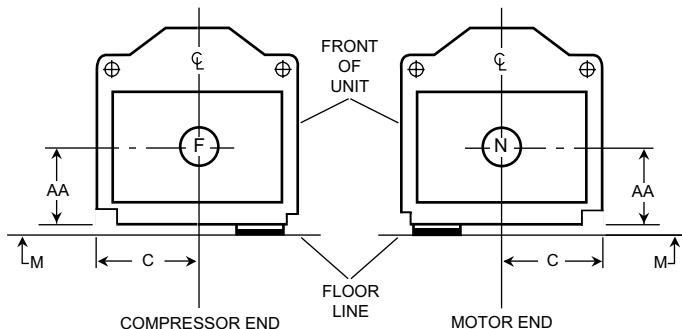

SHELL CODES	3 PASS	
	IN	OUT
M-Z	F	N
	N	F

COMPACT WATER BOXES - 150 PSI RECTANGULAR

EVAP SHELL CODE	NOZZLE PIPE SIZE (IN)			EVAPORATOR NOZZLE DIMENSIONS (FT-IN.)				
	NO. OF PASSES			C	1-PASS	2-PASS		3-PASS
	1	2	3		AA ⁵	AA ⁵	EE	AA ⁵
M,N	18	14	12	2'-4 1/2"	2'-2"	2'-2"	1'-1"	2'-2"
P,Q	18	14	12	2'-5 1/2"	2'-2 3/4"	2'-2 3/4"	1'-1"	2'-2 3/4"
RP,RR,RT, R2,R4,R6,W	20	18	14	2'-8"	2'-7 1/16"	2'-7 1/16"	1'-3"	2'-7 1/16"
RQ,RS,RV, R3,R4,R5,S	20	18	14	2'-8"	2'-8 1/4"	2'-8 1/4"	1'-3"	2'-8 1/4"
X,Z	20	18	14	2'-11 1/2"	2'-10 1/2"	2'-10 1/2"	1'-3"	2'-10 1/2"

See Notes on pg 39

Dimensions (Ft. - In.) Evap Compact Waterboxes



ONE PASS EVAPORATORS, CODES

DIM.	A	C,D	E,F	G,H	J,K,L	M,N	P,Q	R,S,W	X,Z
F	1'-2 1/4"	1'-3"	1'-3 1/2"	1'-2 7/8"	1'-4 5/8"	1'-11 3/4"	1'-11 3/4"	2'-0 3/4"	



TWO PASS EVAPORATORS, CODES

DIM.	A	C,D	E,F	G,H	J,K,L	M,N	P,Q	R,S,W	X,Z
F	1'-2 1/4"	1'-3"	1'-3 1/2"	1'-2 7/8"	1'-4 5/8"	1'-11 3/4"	1'-11 3/4"	2'-0 3/4"	
G	0'-6 1/2"	0'-7"	0'-7 1/2"	0'-8 1/4"	0'-9 1/2"	1'-3"	1'-3"	1'-4 3/4"	



LD07619

THREE PASS EVAPORATORS, CODES

DIM.	A	C,D	E,F	G,H	J,K,L	M,N	P,Q	R,S,W	X,Z
F	1'-2 1/4"	1'-3"	1'-3 1/2"	1'-2 7/8"	1'-4 5/8"	1'-11 3/4"	1'-11 3/4"	2'-0 3/4"	

See Notes on page 41.

Dimensions (Ft. - In.) – Nozzle Arrangements

CONDENSERS – COMPACT WATER BOXES

1-PASS

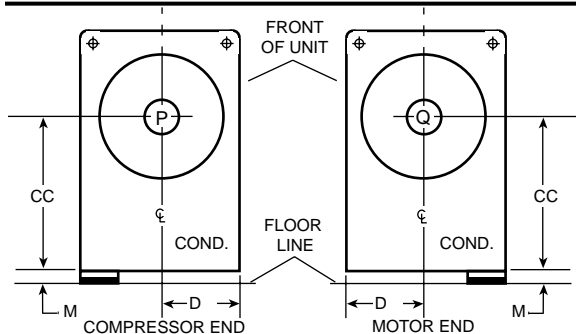

NOZZLE ARRANGEMENTS		
NO. OF PASSES	COND.	
	IN	OUT
1	P	Q
	Q	P

2-PASS

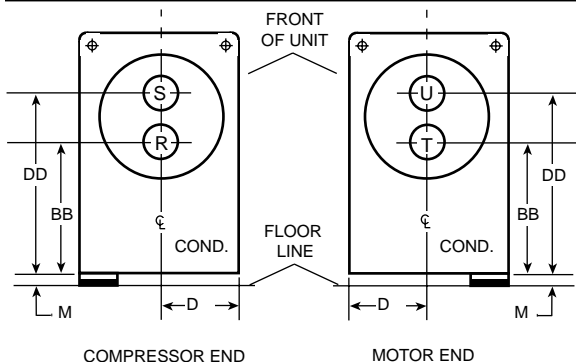

NOZZLE ARRANGEMENTS		
NO. OF PASSES	COND.	
	IN	OUT
2	R	S
	T	U

3-PASS

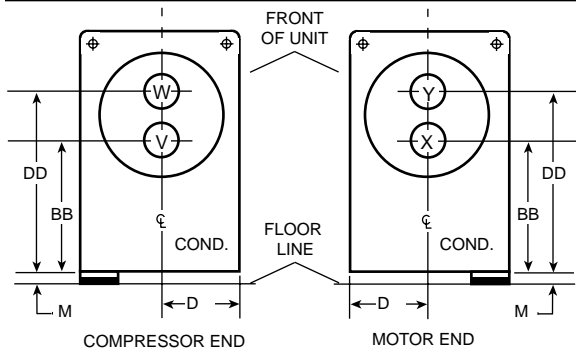

NOZZLE ARRANGEMENTS		
NO. OF PASSES	COND.	
	IN	OUT
3	v	y
	x	w

COMPACT WATER BOXES - 150 PSI ROUND

CONDENSER SHELL CODE	NOZZLE PIPE SIZE (IN)								
	NO. OF PASSES			D	1-PASS	2-PASS		3-PASS	
	1	2	3			BB ⁵	DD ⁵	BB ⁵	DD ⁵
A	10	6	6	1'-3"	2'-4"	1'-9 1/2"	2'-10 1/2"	1'-9 1/2"	2'-10 1/2"
C,D	12	8	6	1'-3 1/2"	2'-6"	1'-10 3/8"	3'-1 5/8"	1'-10 3/8"	3'-1 5/8"
E,F	14	10	8	1'-5 1/2"	2'-8"	1'-11 3/4"	3'-4 1/4"	1'-11 3/4"	3'-4 1/4"
J,K,L	16	10	10	1'-8"	3'-0"	2'-2"	3'-10"	2'-1 1/4"	3'-10 1/4"
M,N	20	14	10	1'-11"	3'-6"	2'-6 1/4"	4'-5 3/4"	2'-6 1/4"	4'-5 3/4"
P,Q	20	16	14	2'-1 1/4"	3'-8"	2'-8 1/4"	4'-7 3/4"	2'-6 3/4"	4'-7 3/4"
R,S	20	18	14	2'-3 1/2"	3'-10 1/2"				
T,V,W	24	18	16	2'-5 1/2"	3'-11 1/2"	2'-10 1/2"	5'-0 1/2"	2'-10 1/2"	5'-0 1/2"
X,Z	24	20	16	2'-8"	4'-1 1/4"	2'-9 1/2"	5'-5"	2'-9 1/2"	5'-5"

NOTES:

- Standard water nozzles are furnished as welding stub-outs with Victaulic grooves, allowing the option of welding, flanges, or use of Victaulic couplings. Factory-installed, class 150 (ANSI B16.5, round slip-on, forged carbon steel with 1/16" raised face), water flanged nozzles are optional (add 1/2" to nozzle length). Companion flanges, nuts, bolts, and gaskets are not furnished.
- One-, two- and three-pass nozzle arrangements are available only in pairs shown and for all shell codes. Any pair of evaporator nozzles may be used in combination with any pair of condenser nozzles.
- Evaporator and condenser water must enter the water box through the bottom connection to achieve rated performance.
- Connected piping should allow for removal of compact water boxes for tube access and cleaning.
- Add dimension "M" as shown on the unit dimensions page for the appropriate isolator type.
- Standard 150 PSI design pressure boxes shown.

Dimensions (Ft. - In.) - Cond Compact Waterboxes

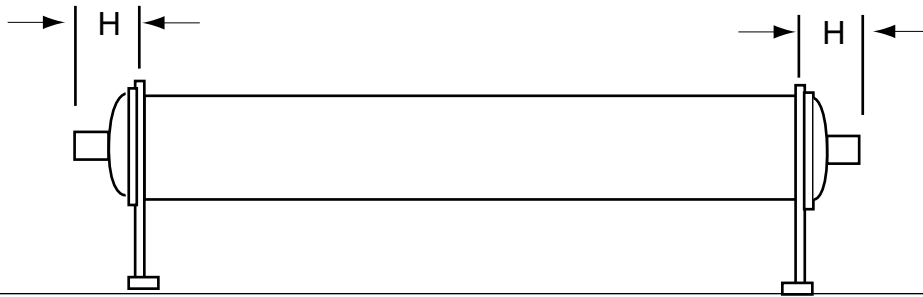

ONE PASS CONDENSERS, CODES

DIM.	A	C,D	E,F	J,K,L	M,N	P,Q	R,S	T,V,W	X,Z
H	1'-1 7/8"	1'-1 7/8"	1'-3"	1'-4"	1'-2 7/8"	1'-4 7/8"			1'-9 3/4"



TWO PASS CONDENSERS, CODES

DIM.	A	C,D	E,F	J,K,L	M,N	P,Q	R,S	T,V,W	X,Z
H	1'-1 7/8"	1'-1 7/8"	1'-3"	1'-4"	1'-2 7/8"	1'-4 7/8"			1'-9 3/4"
J	0'-5 7/8"	0'-6 1/2"	0'-7"	0'-7 1/2"	0'-7 3/4"	0'-9 1/2"			1'-1 7/8"



THREE PASS CONDENSERS, CODES

DIM.	A	C,D	E,F	J,K,L	M,N	P,Q	R,S	T,V,W	X,Z
H	1'-1 7/8"	1'-1 7/8"	1'-3"	1'-4"	1'-2 7/8"	1'-4 7/8"			1'-9 3/4"

See Notes on page 41.

Dimensions (Ft. - In.) – Nozzle Arrangements

EVAPORATORS – MARINE WATER BOXES

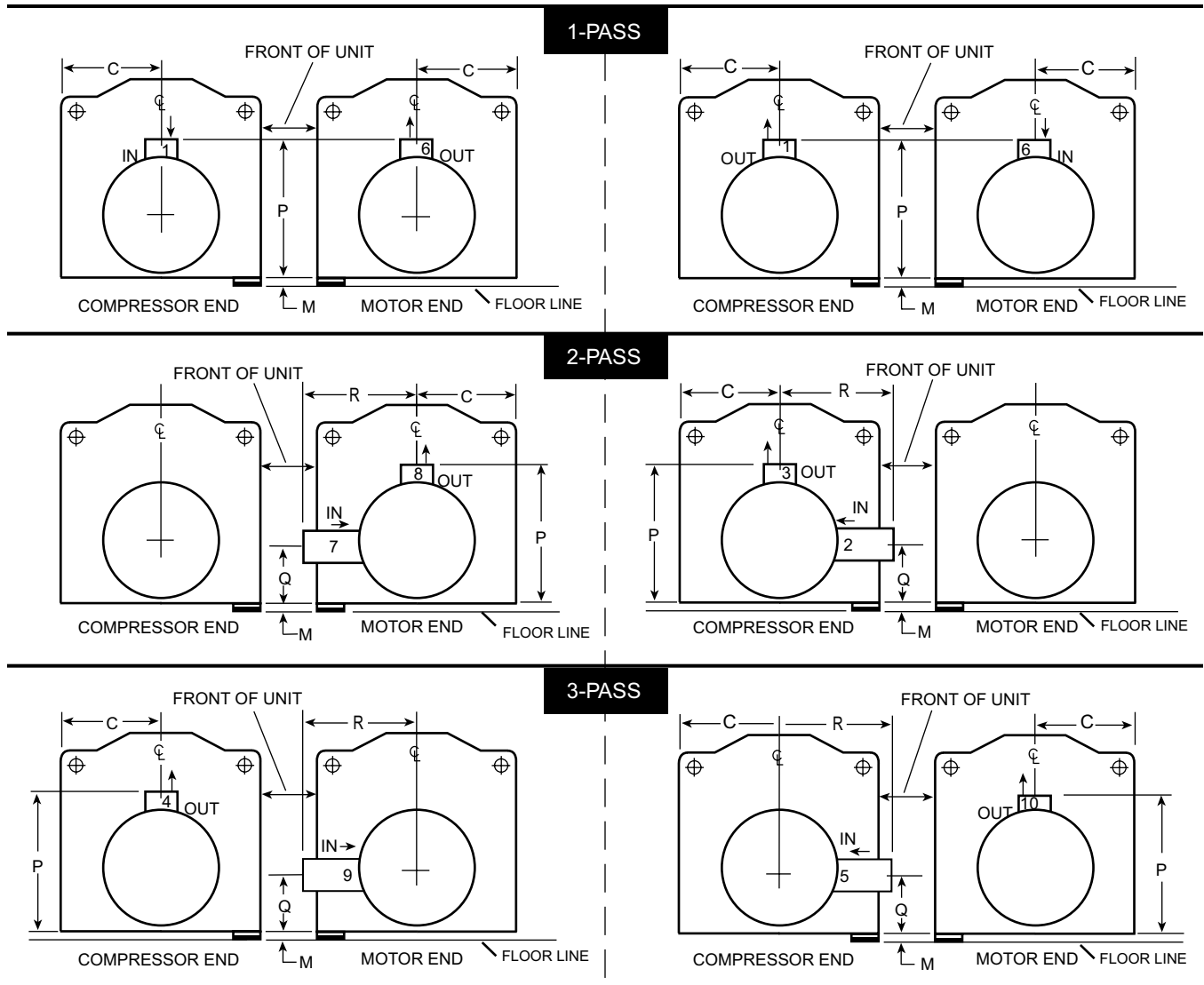

LD07175a

CONDENSER SHELL CODE				MARINE WATER BOXES - 150 PSI ROUND								
EVAP SHELL CODE	NOZZLE PIPE SIZE (IN)			C	1-PASS			2-PASS		3-PASS		
	NO. OF PASSES				P ⁵	P ⁵	Q ⁵	R	P ⁵	Q ⁵	R	
	1	2	3									
A	8	6	4	1'-3 1/2"	3'-7"	3'-7"	0'-11"	1'-3 1/4"	3'-7"	0'-11"	1'-3 1/4"	
C,D	10	8	6	1'-5 1/2"	3'-11"	3'-11"	0'-10"	1'-6 1/2"	3'-11"	0'-10"	1'-6 1/2"	
E,F	14	10	8	1'-7 1/2"	4'-3"	4'-3"	0'-11"	1'-9 1/2"	4'-3"	0'-11"	1'-9 1/2"	
G,H	14	10	8	2'-0"	4'-5 1/2"	4'-5 1/2"	1'-0 1/2"	1'-10 7/8"	4'-5 1/2"	0'-11"	1'-9 7/8"	
J,K,L	16	12	10	2'-1 1/4"	4'-11"	4'-11"	1'-2"	2'-0 5/8"	4'-11"	0'-10"	2'-0 1/8"	
M,N	18	14	12	2'-4 1/2"	5'-9 1/2"	5'-9 1/2"	1'-4 1/4"	2'-7 3/4"	5'-9 1/2"	1'-1 7/8"	2'-4 3/4"	
P,Q	18	14	12	2'-5 1/2"	6'-1 1/8"	6'-1 1/8"	1'-4 3/4"	2'-8 3/4"	6'-1 1/8"	1'-3 1/2"	2'-8 7/8"	
R,S	20	18	14	2'-8"								
W	20	18	14	2'-8"								
X,Z	20	18	14	2'-11 1/2"	6'-11 1/2"	6'-11 1/2"	2'-1 3/4"	3'-2 1/8"	6'-11 1/2"	1'-8 1/4"	3'-2 1/8"	

See Notes on page 44.

Dimensions (Ft. - In.) – Nozzle Arrangements

EVAPORATOR 1-PASS	
IN	OUT
1	6
6	1

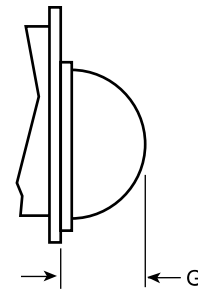
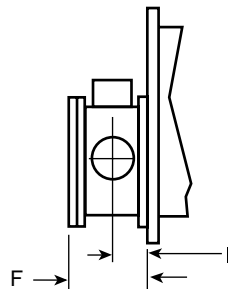

(2-PASS RETURN HEAT)

EVAPORATOR 2-PASS	
IN	OUT
2	3
7	8

EVAPORATOR 3-PASS	
IN	OUT
5	10
9	4

EVAP SHELL CODE	1-PASS		2-PASS			3-PASS	
	F	I	F	G	I	F	I
A	1'-7"	0'-8 3/4"	1'-5"	0'-6 1/2"	0'-7 3/4"	1'-5"	0'-7 3/4"
C,D	1'-10 3/4"	0'-10 5/8"	1'-8 5/8"	0'-7"	0'-9 1/2"	1'-8 5/8"	0'-9 1/2"
E,F	2'-1 3/4"	1'-0 1/8"	1'-10"	0'-7 1/2"	0'-10 1/4"	1'-10"	0'-10 1/4"
G,H	2'-5 5/8"	1'-1 7/8"	2'-5 5/8"	1'-9 7/8"	1'-1 7/8"	2'-5 5/8"	1'-1 7/8"
J,K,L	2'-9 5/16"	1'-3 1/2"	2'-9 5/16"	2'-0 5/8"	1'-3 1/2"	2'-9 5/16"	1'-3 1/2"
M,N	2'-11"	1'-4"	2'-6"	1'-0 1/4"	1'-1 1/2"	2'-4"	1'-0 1/4"
P,Q	3'-5"	1'-7"	3'-0"	0'-11"	1'-4 1/2"	2'-10"	1'-3 1/4"
R,S,W							
X,Z	3'-1"	1'-4 1/4"	2'-8 1/2"	1'-2"	1'-1 5/8"	2'-6 1/2"	1'-1"

NOTES:

1. All dimensions are approximate. Certified dimensions are available upon request.
2. Standard water nozzles are Schedule 40 pipe size, furnished as welding stub-outs with Victaulic grooves, allowing the option of welding, flanges, or use of Victaulic couplings. Factory-installed, class 150 (ANSI B16.5, round slip-on, forged carbon steel with 1/16" raised face), water flanged nozzles are optional (add 1/2" to nozzle length). Companion flanges, nuts, bolts, and gaskets are not furnished.
3. One-, two-, and three-pass nozzle arrangements are available only in pairs shown and for all shell codes. Any pair of evaporator nozzles may be used in combination with any pair of condenser nozzles. Compact water boxes on one heat exchanger may be used with Marine Water Boxes on the other heat exchanger.
4. Condenser water must enter the water box through the bottom connection for proper operation of the sub-cooler to achieve rated performance.
5. Add dimension "M" as shown on pages per unit dimensions page for the appropriate isolator type.

CONDENSERS – MARINE WATER BOXES

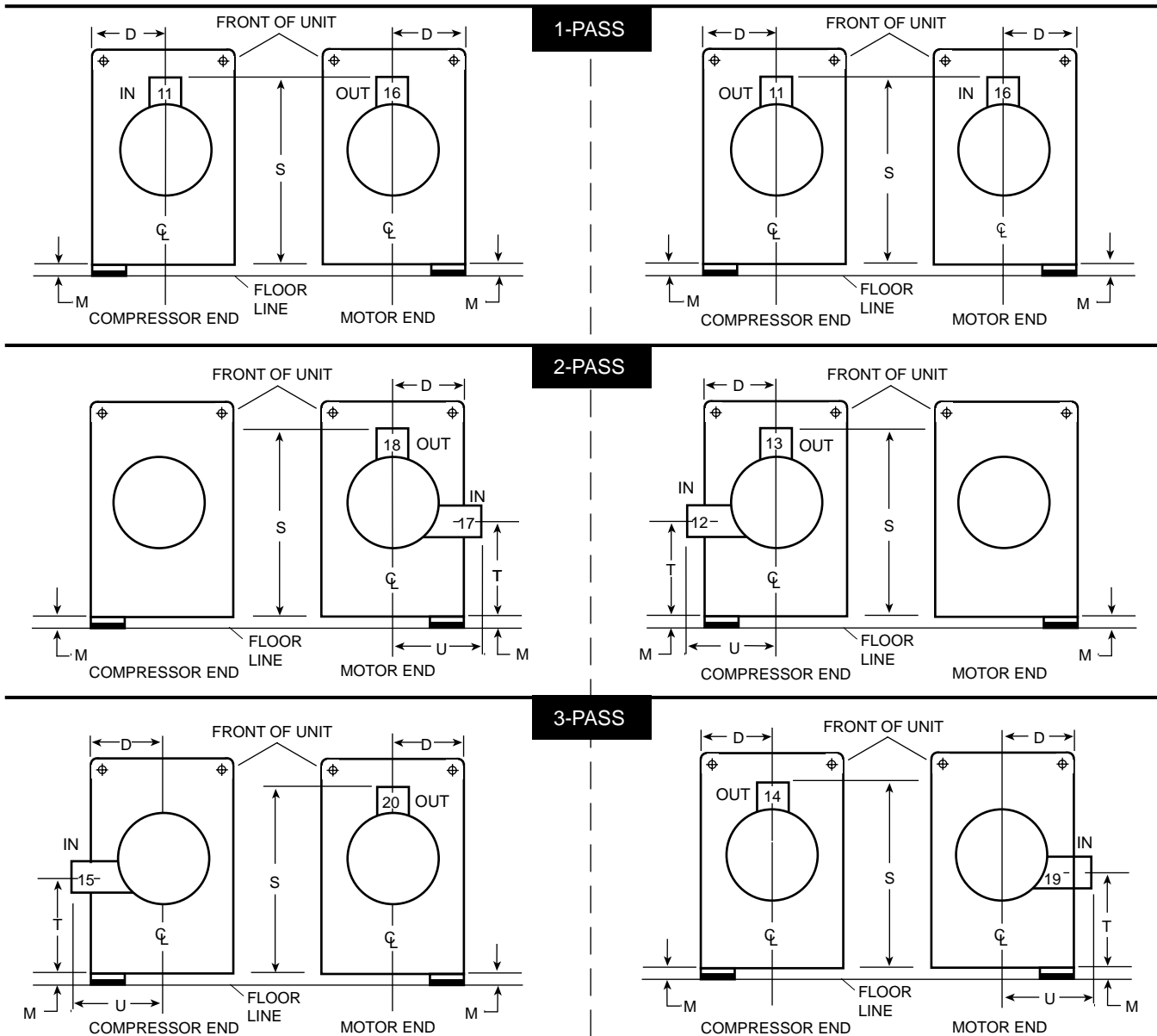

MARINE WATER BOXES - 150 PSI ROUND

CONDENSER SHELL CODE	NOZZLE PIPE SIZE(IN)										
	NO. OF PASSES			1-PASS		2-PASS			3-PASS		
	1	2	3	D	S ⁵	S ⁵	T ⁵	U	S ⁵	T ⁵	U
A	10	6	6	1'-3"	3'-11"	3'-11"	1'-8"	1'-3 3/8"	3'-11"	1'-8"	1'-3 3/8"
C,D	12	8	6	1'-3 1/2"	4'-3"	4'-3"	1'-8"	1'-6 1/2"	4'-3"	1'-8"	1'-6 1/2"
E,F	14	10	8	1'-5 1/2"	4'-7"	4'-7"	1'-10"	1'-9"	4'-7"	1'-10"	1'-9"
J,K,L	16	10	10	1'-8"	5'-1"	5'-1"	1'-10"	1'-10 7/8"	5'-1"	1'-10"	1'-10 7/8"
M,N	20	14	10	1'-11"	5'-9"	5'-9"	2'-5"	2'-1 5/8"	5'-9"	2'-4"	1'-11 7/8"
P,Q	20	16	14	2'-1 1/4"	6'-3 1/2"	6'-3 1/2"	2'-6"	2'-6 1/2"	6'-3 1/2"	2'-4"	2'-4 5/8"
R,S	20	18	14	2'-3 1/2"							
T,V,W	24	18	16	2'-5 1/2"							
X,Z	24	20	16	2'-8"	7'-3"	7'-3"	2'-3 1/4"	2'-10"	7'-3"	2'-3 1/4"	2'-10"

See Notes on pg 44

Dimensions (Ft. - In.) – Nozzle Arrangements

CONDENSER	
1-PASS	
IN	OUT
11	16
16	11

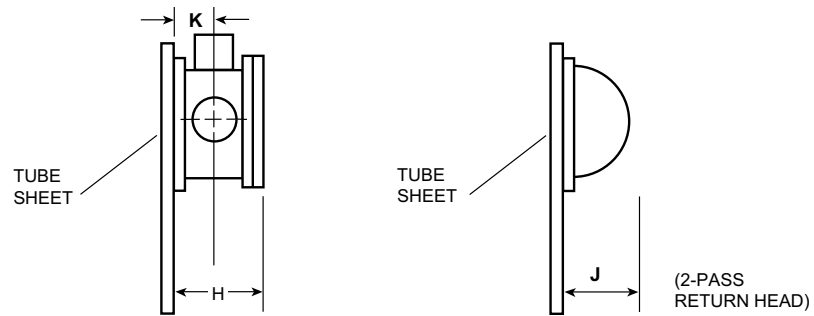

CONDENSER	
2-PASS	
IN	OUT
12	13
17	18

CONDENSER	
3-PASS	
IN	OUT
15	20
19	14

COND SHELL CODE	1-PASS		2-PASS			3-PASS	
	H	K	H	J	K	H	K
A	1'-9"	0'-9 7/8"	1'-4 3/4"	0'-6"	0'-7 3/4"	1'-4 3/4"	0'-7 3/4"
C,D	2'-0"	0'-11 1/8"	1'-7 1/2"	0'-6 3/8"	0'-9"	1'-7 1/2"	0'-9"
E,F	2'-0 1/2"	0'-11 1/2"	1'-10 1/4"	0'-7"	0'-9 7/8"	1'-10 1/4"	0'-9 7/8"
J,K,L	2'-8 3/8"	1'-3 3/8"	2'-8 3/8"	0'-7 1/2"	1'-3 3/8"	2'-8 3/8"	1'-3 3/8"
M,N	2'-11"	1'-4"	2'-11"	1'-0"	1'-4"	2'-11"	1'-4"
P,Q	2'-9 3/4"	1'-3 3/4"	2'-8"	0'-9 1/2"	1'-2 3/4"	2'-5 1/4"	1'-1 1/2"
R,S							
T,V,W							
X,Z	3'-5 1/2"	1'-6 1/2"	3'-0 1/2"	1'-2"	1'-4 1/4"	2'-9 1/2"	1'-2"

NOTES:

1. All dimensions are approximate. Certified dimensions are available upon request.
2. Standard water nozzles are Schedule 40 pipe size, furnished as welding stub-outs with Victaulic grooves, allowing the option of welding, flanges, or use of Victaulic couplings. Factory-installed, class 150 (ANSI B16.5, round slip-on, forged carbon steel with 1/16" raised face), water flanged nozzles are optional (add 1/2" to nozzle length). Companion flanges, nuts, bolts, and gaskets are not furnished.
3. One-, two-, and three-pass nozzle arrangements are available only in pairs shown and for all shell codes. Any pair of evaporator nozzles may be used in combination with any pair of condenser nozzles. Compact water boxes on one heat exchanger may be used with Marine Water Boxes on the other heat exchanger.
4. Condenser water must enter the water box through the bottom connection for proper operation of the sub-cooler to achieve rated performance.
5. Add dimension "M" as shown on pages per unit dimensions page for the appropriate isolator type.

Weights - English

TABLE 7 – APPROXIMATE UNIT WEIGHT INCLUDING MOTOR*

Shells	Compressor	Shipping Weight (Lbs.)	Operating Weight (Lbs.)	Est. Refrigerant Charge (Lbs.) ¹
A-A	Q3	13,100	15,000	810
C-C	Q3, Q4	14,920	17,940	1,240
C-C	Q5	15,330	18,350	1,240
D-D	Q3, Q4	17,215	21,100	1,680
D-D	Q5	17,625	21,510	1,680
E-E	Q3, Q4	17,950	22,160	1,710
E-E	Q5, Q6, Q7, P7	18,360	22,570	1,710
F-F	Q5, Q6, Q7, P7	18,720	23,880	2,175
G-E	P8	20,300	24,200	1,990
H-F	P8, P9	23,100	28,000	2,610
J-J	P8, P9	24,000	29,100	2,550
L-L	P8, P9	27,400	33,900	3,165
K-K	H9	28,530	36,000	2,925
K-K	K1			2,925
M-M	H9	34,200	43,600	3,665
M-M	K1, K2	38,300	47,100	3,665
N-N	K1, K2	40,893	50,800	4,225
N-N	K3			4,225
P-P	K1, K2	41,500	51,900	3,855
Q-Q	K1, K2	45,300	56,800	4,255
Q-Q	K3			4,255
R-R	K3			4,660
R-R	K4			4,785
S-S	K4			4,940
S-V	K4			5,500
X-T	K4			5,125
X-X	K4			5,625
W-W	K7	82,600	99,800	6,900
Z-Z	K7	81,500	102,800	6,275

* Refer to product drawings for detailed weight information.

Weights

TABLE 8 EVAPORATOR MARINE WATER BOX WEIGHTS (Lbs.)
(To be added to Standard Unit weights shown on Table 7)

Evap. Code	SHIPPING WEIGHT			OPERATING WEIGHT		
	INCREASE - Lbs.			INCREASE - Lbs.		
	1-Pass	2-Pass	3-Pass	1-Pass	2-Pass	3-Pass
A	924	744	978	1,468	1,288	1,522
C,D	1,352	1,114	1,480	2,224	1,986	2,352
E,F	1,878	1,260	2,080	3,378	2,760	3,580
G,H	1,213	1,296	1,293	2,655	2,738	2,735
J,K,L	1,751	1,843	1,856	3,864	3,956	3,969
M,N	4,290	2,036	4,140	7,535	3,264	6,300
P,Q	5,982	3,281	5,724	10,854	5,277	9,442
R,S,W						
X,Z						

TABLE 9 CONDENSER MARINE WATER BOX WEIGHTS (Lbs.)
(To be added to Standard Unit weights shown on Table 7)

Cond. Code	SHIPPING WEIGHT			OPERATING WEIGHT		
	INCREASE - Lbs.			INCREASE - Lbs.		
	1-Pass	2-Pass	3-Pass	1-Pass	2-Pass	3-Pass
A	762	566	810	1,274	1,078	1,322
C,D	946	778	1,046	1,692	1,524	1,792
E,F	726	811	791	1,337	1,722	1,702
J,K,L	1,029	1,167	1,151	2,309	2,447	2,431
M,N	2,466	1,330	2,324	4,863	2,448	4,582
P,Q	3,700	1,858	3,752	6,561	3,132	5,991
R,S						
V,T,W						
X,Z	5,840	2,953	5,380	9,900	4,649	8,100

Dimensions (mm) – Unit

P & Q COMPRESSOR UNITS

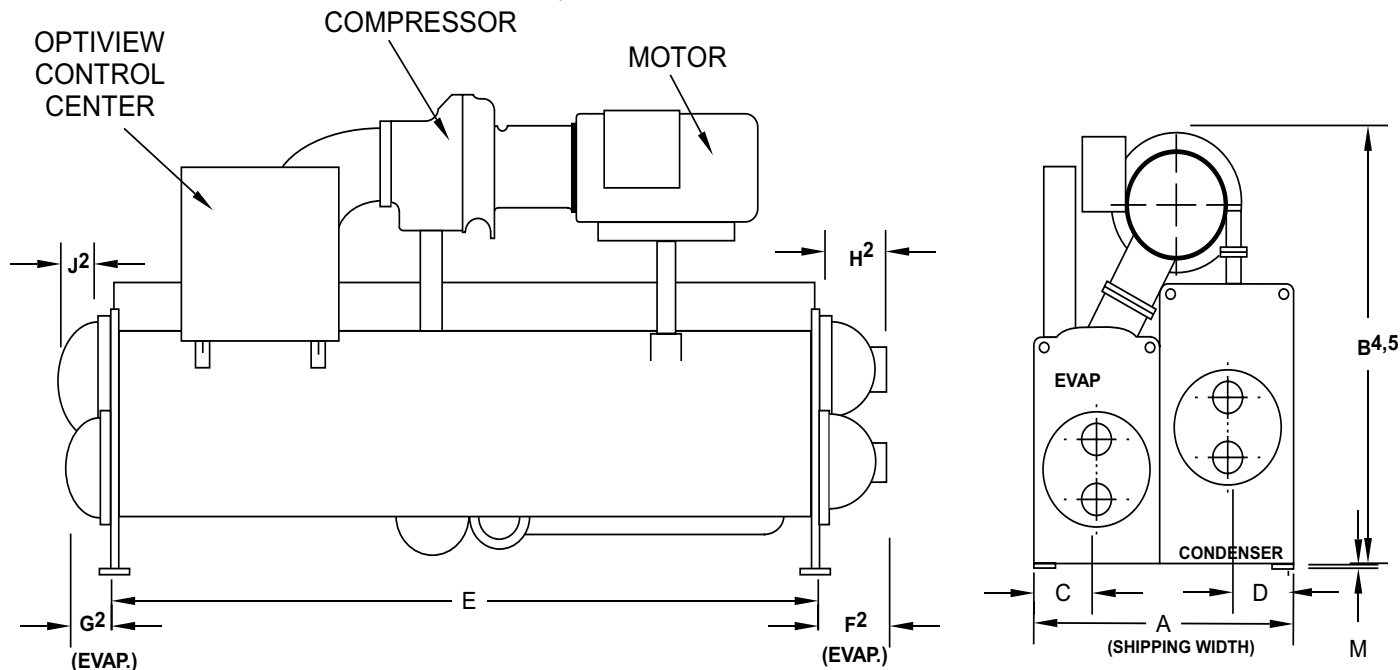

ADDITIONAL OPERATING HEIGHT CLEARANCE	
TYPE OF CHILLER MOUNTING	M
NEOPRENE PAD ISOLATORS	44
SPRING ISOLATORS 25mm DEFLECTION	25
DIRECT MOUNT	19

Q3 COMPRESSOR			
EVAPORATOR-CONDENSER SHELL CODES			
	A-A	C-C	D-D
A	1549	1676	1676
B	2134	2229	2229
C	394	445	445
D	381	394	394
E	3658	3658	4877

P7, Q7 COMPRESSOR		
EVAPORATOR - CONDENSER SHELL CODES		
	E-E	F-F
A	1,880	1,880
B	2,299	2,299
C	495	495
D	445	445
E	3,658	4,877

Q4 COMPRESSOR			
EVAPORATOR-CONDENSER SHELL CODE			
	C-C	D-D	E-E
A	1676	1676	2134
B	2197	2197	2350
C	445	445	495
D	394	394	445
E	3658	4877	3658

P8 COMPRESSOR				
EVAPORATOR - CONDENSER SHELL CODES				
	E-E	F-F	G-G	H-H
A	2,108	2,108	2,299	2,299
B	3,137	3,137	3,289	3,289
C	610	610	641	641
D	445	445	508	508
E	3,658	4,877	3,658	4,877

Q5 COMPRESSOR				
EVAPORATOR-CONDENSER SHELL CODES				
	C-C	D-D	E-E	F-F
A	1676	1676	2134	2134
B	2403	2403	2515	2515
C	445	445	495	495
D	394	394	445	445
E	3658	4877	3658	4877

P9 COMPRESSOR			
EVAPORATOR - CONDENSER SHELL CODES			
	H-F	J-J	L-L
A	2,108	2,299	2,299
B	3,045	3,200	3,200
C	610	641	641
D	445	508	508
E	4,877	3,658	4,877

Q6 COMPRESSOR		
EVAPORATOR-CONDENSER SHELL CODES		
	E-E	F-F
A	2134	2134
B	2515	2515
C	495	495
D	445	445
E	3658	4877

Dimensions (mm) – Unit

H COMPRESSOR UNITS

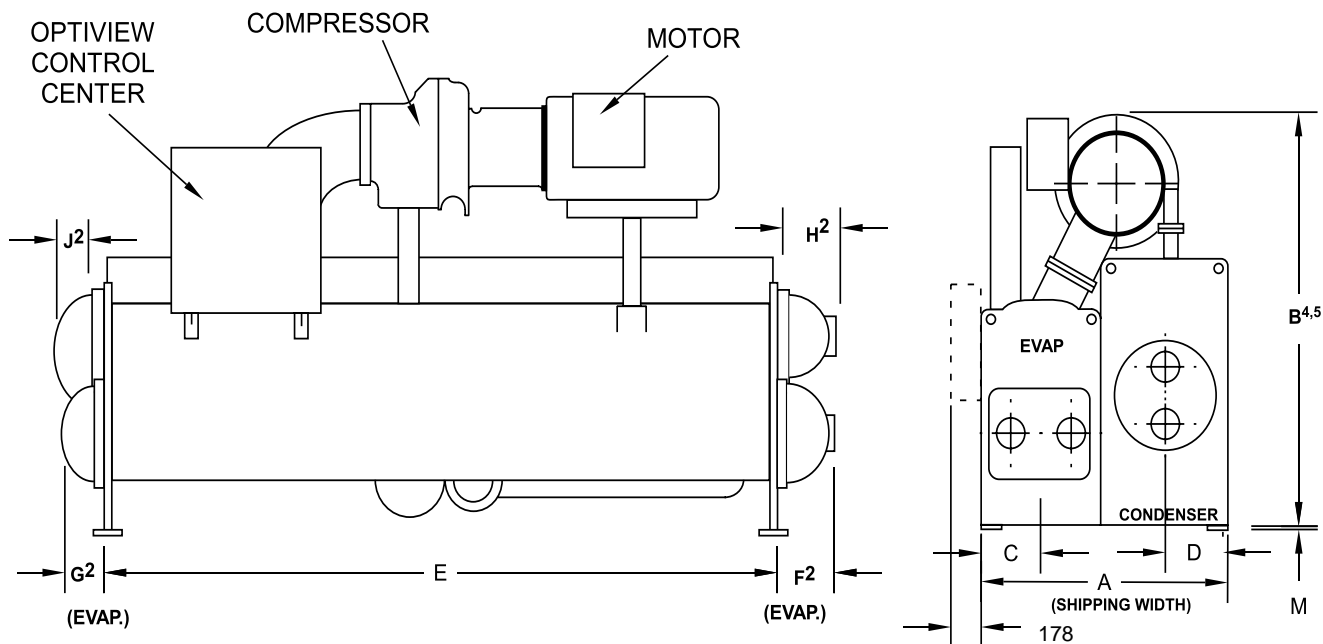

ADDITIONAL OPERATING HEIGHT CLEARANCE	
TYPE OF CHILLER MOUNTING	M
NEOPRENE PAD ISOLATORS	44
SPRING ISOLATORS 25mm DEFLECTION	25
DIRECT MOUNT	19

H9 COMPRESSORS		
EVAP. - COND. SHELL CODES		
	K-K	M-M
A	2,300	2,743
B	2,872	3,100
C	641	724
D	508	648
E	4,268	4,268

NOTES:

1. All dimensions are approximate. Certified dimensions are available on request.
2. For all water boxes (compact shown above), determine overall unit length by adding water box depth to tube sheet length.
3. Water nozzles can be located on either end of unit. Add 13 mm to nozzle length for flanged connections.
4. To determine overall height, add dimension "M" for the appropriate isolator type.
5. Use of motors with motor hoods may increase overall unit dimensions.

Dimensions (mm) – Unit

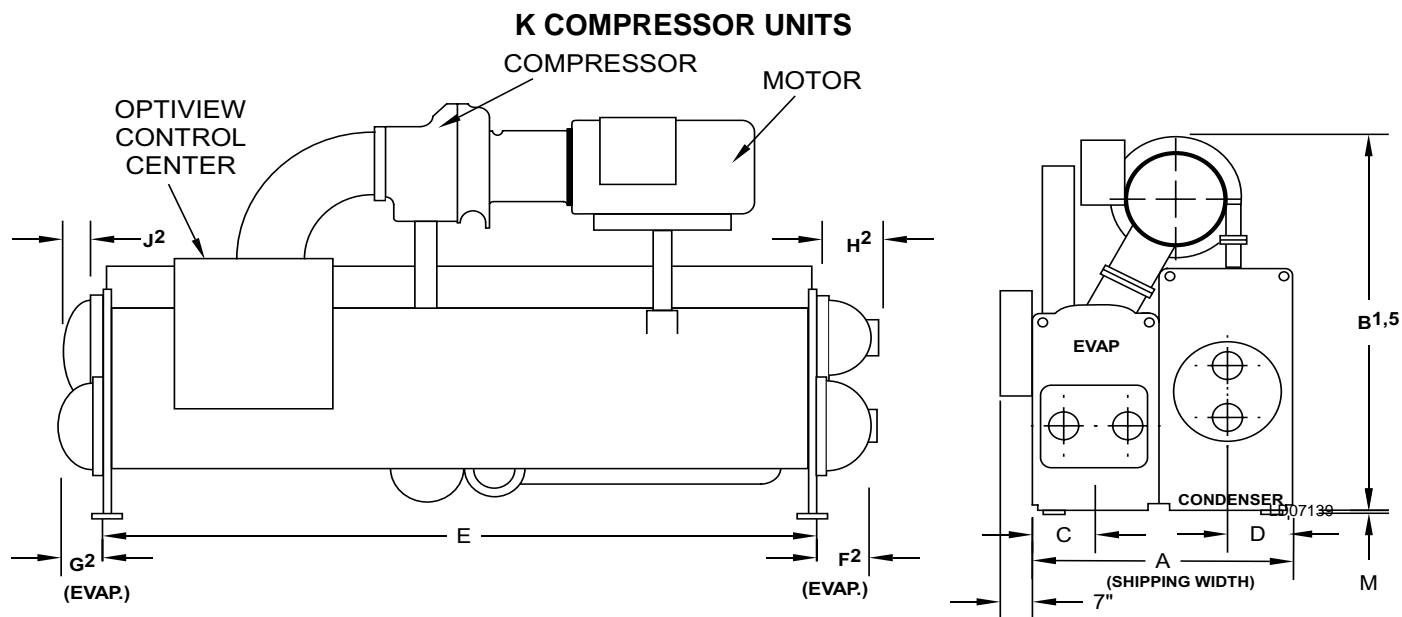

K1 Compressor, Evaporator-Condenser Shell Codes

	K-K	M-M	N-N	P-P	Q-Q
A	2299	2616	2616	2781	2781
B		3454	3454	3493	3493
C	641	724	724	749	749
D	508	584	584	641	641
E	4267	4267	4877	4267	4877

K2 Compr., Evaporator-Condenser Shell Codes

	M-M	N-N	P-P	Q-Q
A	2616	2616	2781	2781
B	3454	3454	3480	3480
C	724	724	749	749
D	584	584	641	641
E	4267	4877	4267	4877

K4 Compressor, Evaporator-Condenser Shell Codes

	R-R	S-S	S-V	X-T	X-X
A	2972	2972	3124	3302	3429
B					
C	813	813	813	902	902
D	699	699	749	749	813
E	4877	5486	5486	4877	4877

Additional Operating Height Clearance

Type of Chiller Mounting	M
Neoprene Pad Isolators	44
Spring Isolators 1" Deflection	25
Direct Mount	19

K3 Compr., Evap.-Cond. Shell Codes

	N-N	Q-Q	R-R
A	2616	2781	2972
B		3505	3607
C	724	749	813
D	584	641	699
E	4877	4877	4877

K7 Compr., Evap.-Cond Shell Codes

	W-W	Z-Z
A	3124	3429
B	3708	3912
C	813	902
D	749	813
E	6706	5486

NOTES:

1. All dimensions are approximate. Certified dimensions are available on request.
2. For all water boxes (compact shown above), determine overall unit length by adding water box depth to tube sheet length.
3. Water nozzles can be located on either end of unit. Add 13 mm to nozzle length for flanged connections.
4. To determine overall height, add dimension "M" for the appropriate isolator type.
5. Use of motors with motor hoods may increase overall unit dimensions.
6. Tubesheets are provided with jacking point notches on P and larger shells.

Dimensions (mm) – Nozzle Arrangements

EVAPORATORS – COMPACT WATER BOXES – A THRU K EVAPORATORS

1-PASS

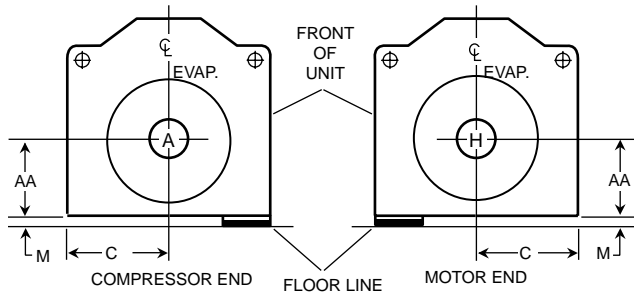

NOZZLE ARRANGEMENTS		
NO. OF PASSES	EVAPORATOR	
	IN	OUT
1	A	H
	H	A

2-PASS

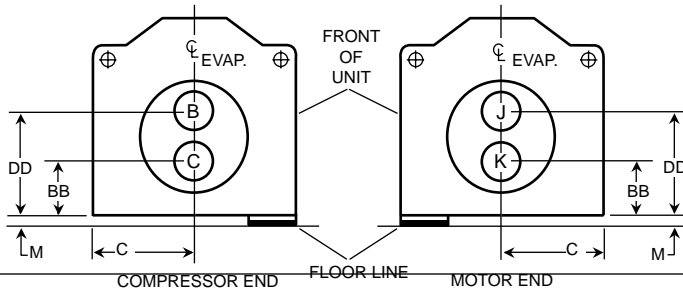

NOZZLE ARRANGEMENTS		
NO. OF PASSES	EVAPORATOR	
	IN	OUT
2	C	B
	K	J

3-PASS

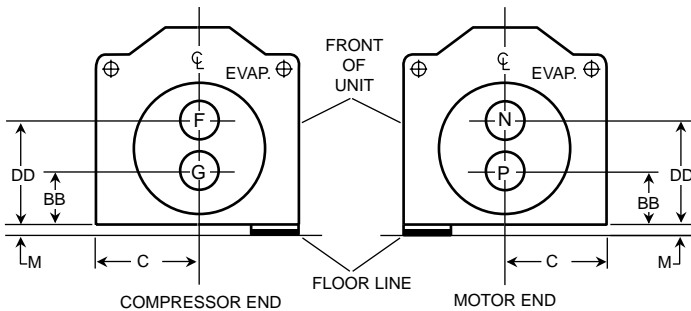

NOZZLE ARRANGEMENTS		
NO. OF PASSES	EVAPORATOR	
	IN	OUT
3	G	N
	P	F

COMPACT WATER BOXES - 150 PSI ROUND

CONDENSER SHELL CODE	NOZZLE PIPE SIZE(IN)			EVAPORATOR NOZZLE DIMENSIONS (MM)					
	NO. OF PASSES			C	1-PASS	2-PASS		3-PASS	
	1	2	3		AA ⁵	BB ⁵	DD ⁵	BB ⁵	DD ⁵
A	8	6	4	394	559	356	762	356	762
C,D	10	8	6	445	610	381	838	381	838
E,F	14	10	8	483	660	406	914	406	914
G,H	14	10	8	610	699	406	991	406	991
J,K,L	16	12	10	641	762	419	1105	432	1092

EVAPORATORS – COMPACT WATER BOXES – M THRU Z EVAPORATORS

1-PASS

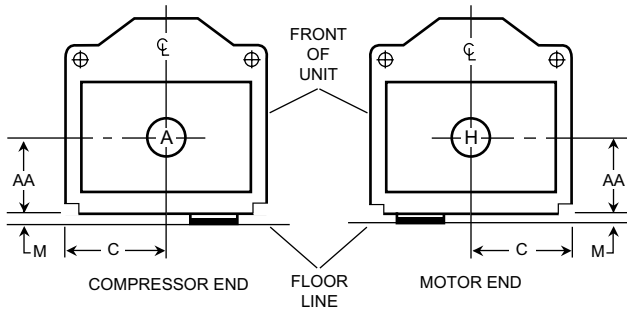

SHELL CODE	1 PASS	
	IN	OUT
M-Z	A	H
	H	A

2-PASS

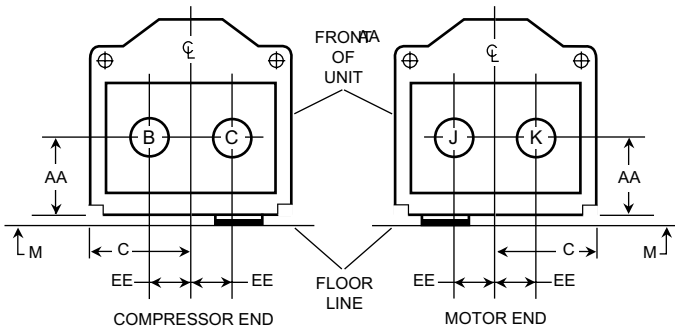

SHELL CODES	2 PASS	
	IN	OUT
M-Z	B	C
	C	B
	J	K
	K	J

3-PASS

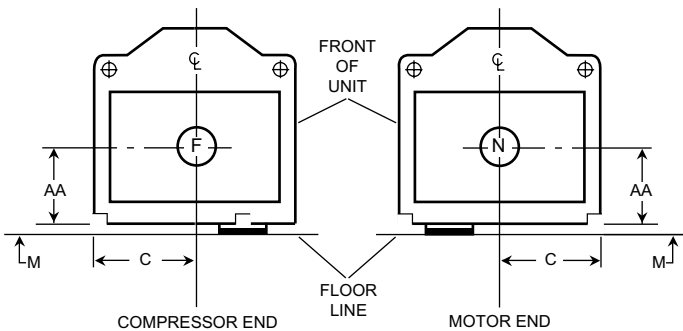

SHELL CODES	3 PASS	
	IN	OUT
M-Z	F	N
	N	F

COMPACT WATER BOXES - 150 PSI RECTANGULAR

EVAP SHELL CODE	NOZZLE PIPE SIZE(IN)			EVAPORATOR NOZZLE DIMENSIONS (MM)				
	NO. OF PASSES			C	1-PASS	2-PASS		3-PASS
	1	2	3		AA ⁵	AA ⁵	EE	AA ⁵
M,N	18	14	12	724	660	660	330	660
P,Q	18	14	12	749	679	679	330	679
RP,RR,RT, R2,R4,R6,W	20	18	14	813	789	789	381	789
RQ,RS,RV, R3,R4,R5,S	20	18	14	813	819	819	381	819
X,Z	20	18	14	902	876	876	381	876

See Notes on page 53.

Dimensions (mm)-Evap Compact Water Boxes

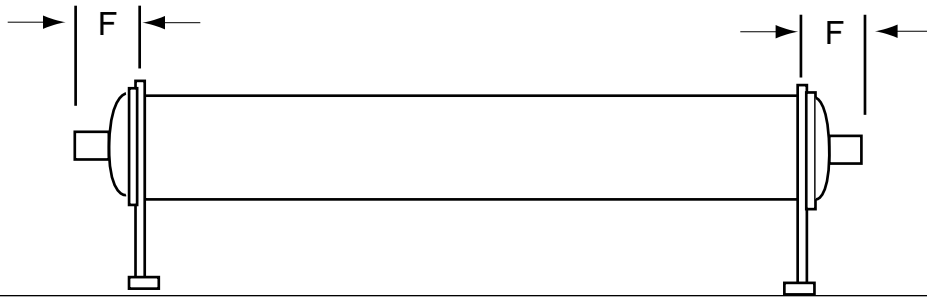

ONE PASS EVAPORATORS, CODES

DIM.	A	C,D	E,F	G,H	J,K,L	M,N	P,Q	R,S,W	X,Z
F	362	381	394	378	422	603	603	629	



TWO PASS EVAPORATORS, CODES

DIM.	A	C,D	E,F	G,H	J,K,L	M,N	P,Q	R,S,W	X,Z
F	362	381	394	378	422	603	603	629	
G	165	178	191	210	241	381	381	425	



LD07619

THREE PASS EVAPORATORS, CODES

DIM.	A	C,D	E,F	G,H	J,K,L	M,N	P,Q	R,S,W	X,Z
F	362	381	394	378	422	603	603	629	

Dimensions (mm) – Nozzle Arrangements

CONDENSERS – COMPACT WATER BOXES

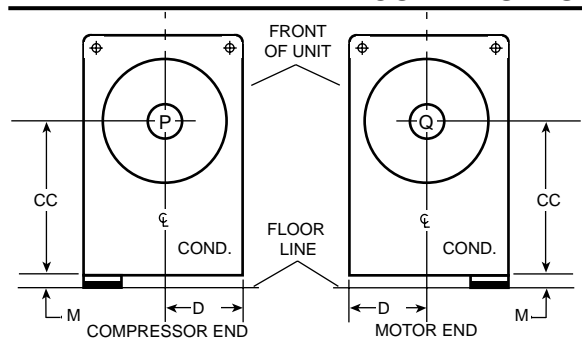

1-PASS

NOZZLE ARRANGEMENTS		
NO. OF PASSES	COND.	
	IN	OUT
1	P	Q
	Q	P

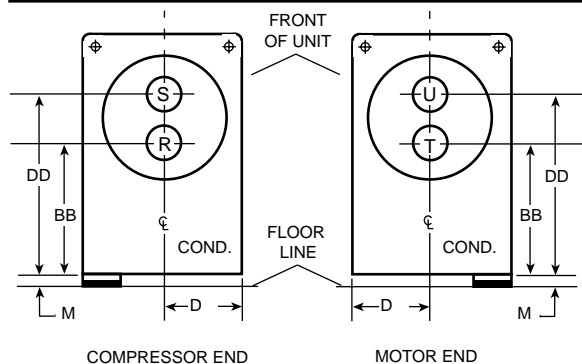

2-PASS

NOZZLE ARRANGEMENTS		
NO. OF PASSES	COND.	
	IN	OUT
2	R	S
	T	U

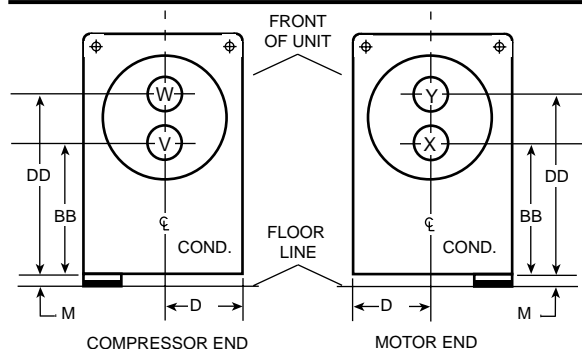

3-PASS

NOZZLE ARRANGEMENTS		
NO. OF PASSES	COND.	
	IN	OUT
3	V	Y
	X	W

COMPACT WATER BOXES - 150 PSI ROUND

CONDENSER SHELL CODE	NOZZLE PIPE SIZE(IN)			D	1-PASS	2-PASS		3-PASS	
	NO. OF PASSES					BB ⁵	DD ⁵	BB ⁵	DD ⁵
A	10	6	6	381	711	546	876	546	876
C,D	12	8	6	394	762	568	956	568	956
E,F	14	10	8	445	813	603	1022	603	1022
J,K,L	16	10	10	508	914	660	1168	641	1175
M,N	20	14	10	584	1067	768	1365	768	1365
P,Q	20	16	14	641	1118	819	1416	781	1416
R,S	20	18	14	699	1181	#####	#####	#####	#####
T,V,W	24	18	16	749	1207	876	1537	876	1537
X,Z	24	20	16	813	1251	851	1651	851	1651

NOTES:

- Standard water nozzles are furnished as welding stub-outs with Victaulic grooves, allowing the option of welding, flanges, or use of Victaulic couplings. Factory-installed, class 150 (ANSI B16.5, round slip-on, forged carbon steel with 1.6 mm raised face), water flanges nozzles are optional (add 13 mm to nozzle length). Companion flanges, nuts, bolts, and gaskets are not furnished.
- One, two and three pass nozzle arrangements are available only in pairs shown and for all shell codes. Any pair of evaporator nozzles may be used in combination with any pair of condenser nozzles.
- Evaporator and condenser water must enter the water box through the bottom connection to achieve rated performance.
- Connected piping should allow for removal of compact water boxes for tube access and cleaning.
- Add dimension "M" as shown on the unit dimensions page for the appropriate isolator type.
- Standard 150 psi (1034 kPa) design pressure water boxes shown.

Dimensions (mm) - Cond Compact Water Boxes



ONE PASS CONDENSERS, CODES

DIM.	A	C,D	E,F	J,K,L	M,N	P,Q	R,S	T,V,W	X,Z
H	352	352	381	406	378	429			552



TWO PASS CONDENSERS, CODES

DIM.	A	C,D	E,F	J,K,L	M,N	P,Q	R,S	T,V,W	X,Z
H	352	352	381	406	378	429			552
J	149	165	178	191	197	241			352



THREE PASS CONDENSERS, CODES

DIM.	A	C,D	E,F	J,K,L	M,N	P,Q	R,S	T,V,W	X,Z
H	352	352	381	406	378	429			552

EVAPORATORS – MARINE WATER BOXES

1-PASS

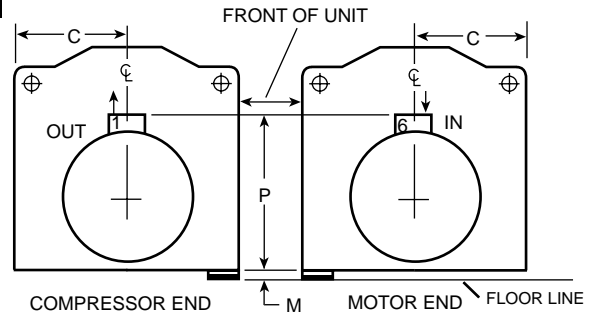
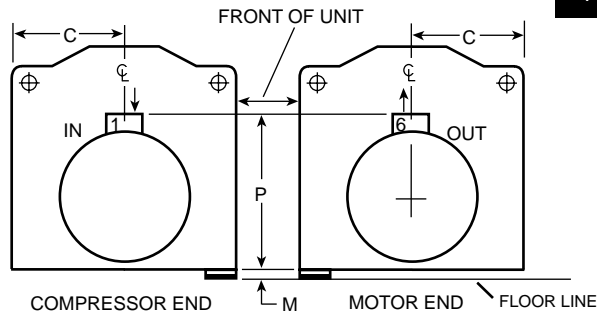

2-PASS

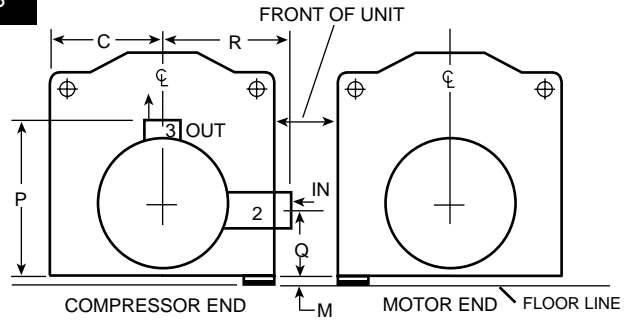
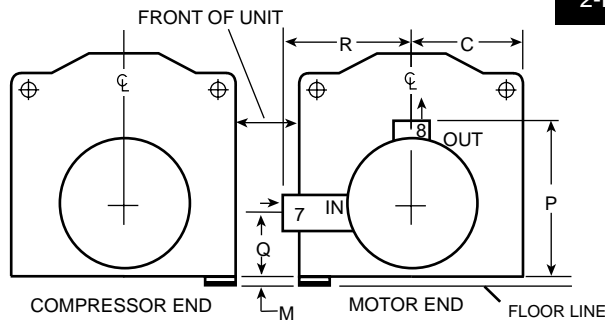

3-PASS

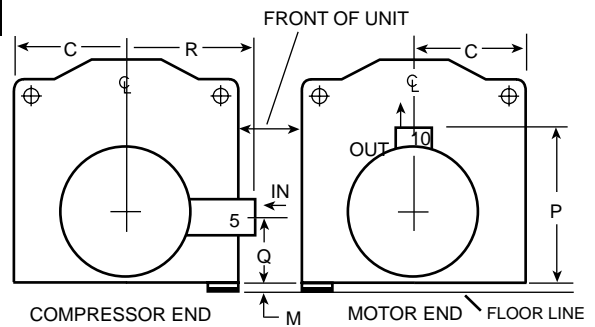
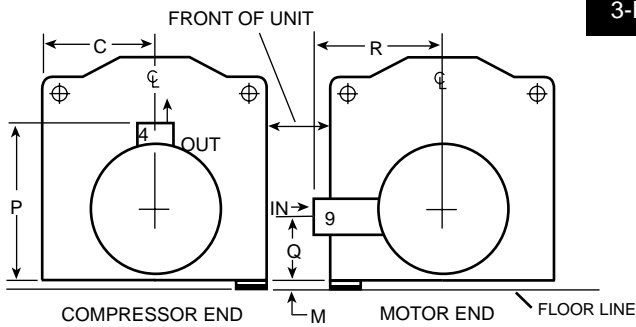

CONDENSER SHELL CODE				MARINE WATER BOXES - 150 PSI ROUND									LD07221
EVAP SHELL CODE	NOZZLE PIPE SIZE (IN)			C	1-PASS	2-PASS			3-PASS				
	1	2	3			P ⁵	P ⁵	Q ⁵	R	P ⁵	Q ⁵	R	
A	8	6	4	394	1092	1092	279	387	1092	279	387		
C,D	10	8	6	445	1194	1194	254	470	1194	254	470		
E,F	14	10	8	495	1295	1295	279	546	1295	279	546		
G,H	14	10	8	610	1359	1359	318	581	1359	279	556		
J,K,L	16	12	10	641	1499	1499	356	625	1499	254	613		
M,N	18	14	12	724	1765	1765	413	806	1765	352	730		
P,Q	18	14	12	749	1857	1857	425	832	1857	394	835		
R,S	20	18	14	813									
W	20	18	14	813									
X,Z	20	18	14	902	2121	2121	654	968	2121	514	968		

See Notes on pf 58.

Dimensions (mm) – Nozzle Arrangements

EVAPORATOR 1-PASS	
IN	OUT
1	6
6	1

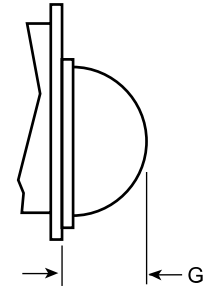
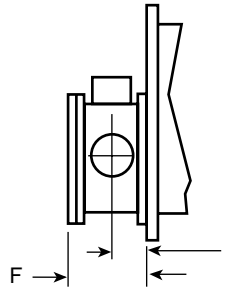

(2-PASS RETURN HEAD)

LD01342BM

EVAPORATOR 2-PASS	
IN	OUT
2	3
7	8

EVAPORATOR 3-PASS	
IN	OUT
5	10
9	4

EVAP SHELL CODE	1-PASS		2-PASS			3-PASS	
	F	I	F	G	I	F	I
A	483	222	432	165	197	432	197
C,D	578	270	524	178	241	524	241
E,F	654	308	559	191	260	559	260
G,H	752	352	752	556	352	752	352
J,K,L	846	394	846	625	394	846	394
M,N	889	406	762	311	343	711	311
P,Q	1041	483	914	279	419	864	387
R,S,W							
X,Z	940	413	826	356	346	775	330

NOTES:

1. All dimensions are approximate. Certified dimensions are available upon request.
2. Standard water nozzles are Schedule 40 pipe size, furnished as welding stub-outs with Victaulic grooves, allowing the option of welding, flanges, or use of Victaulic couplings. Factory-installed, class 150 (ANSI B16.5, round slip-on, forged carbon steel with 1.6 mm raised face), water flanged nozzles are optional (add 13 mm to nozzle length). Companion flanges, nuts, bolts, and gaskets are not furnished.
3. One-, two-, and three-pass nozzle arrangements are available only in pairs shown and for all shell codes. Any pair of evaporator nozzles may be used in combination with any pair of condenser nozzles. Compact water boxes on one heat exchanger may be used with Marine Water Boxes on the other heat exchanger.
4. Water must enter the water box through the bottom connection to achieve rated performance.
5. Add dimension "M" as shown on the unit dimensions page for the appropriate isolator type.

CONDENSERS – MARINE WATER BOXES

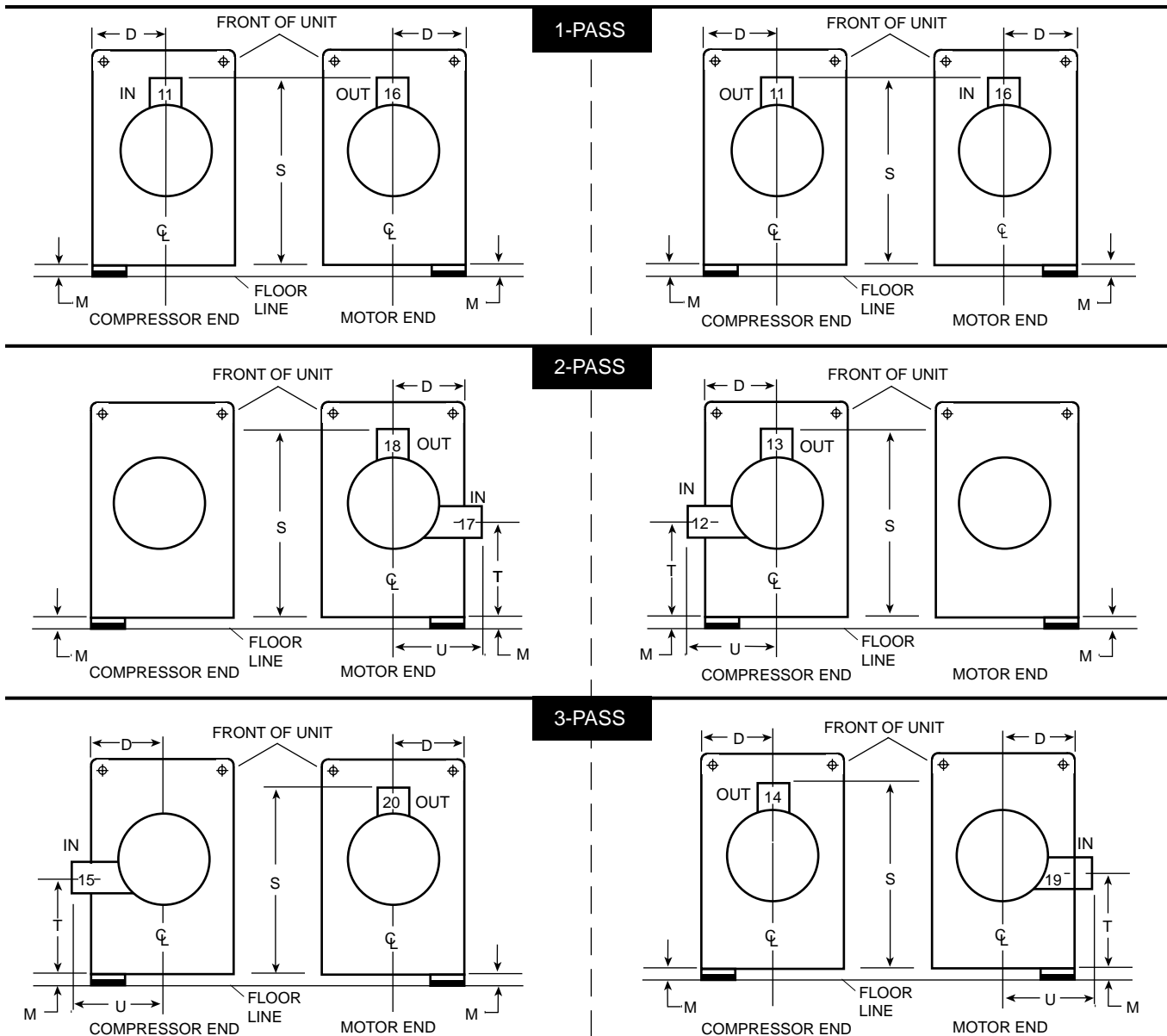

MARINE WATER BOXES - 150 PSI ROUND

CONDENSER SHELL CODE	NOZZLE PIPE SIZE(IN)			D	1-PASS			2-PASS			3-PASS		
	1	2	3		S ⁵	S ⁵	T ⁵	U	S ⁵	T ⁵	U		
A	10	6	6	381	1194	1194	508	391	1194	508	391		
C,D	12	8	6	394	1295	1295	508	470	1295	508	470		
E,F	14	10	8	445	1397	1397	559	533	1397	559	533		
J,K,L	16	10	10	508	1549	1549	559	581	1549	559	581		
M,N	20	14	10	584	1753	1753	737	651	1753	711	606		
P,Q	20	16	14	641	1918	1918	762	775	1918	711	727		
R,S	20	18	14	699									
T,V,W	24	18	16	749									
X,Z	24	20	16	813	2210	2210	692	864	2210	692	864		

Dimensions (mm) – Nozzle Arrangements

CONDENSER	
1-PASS	
IN	OUT
11	16
16	11

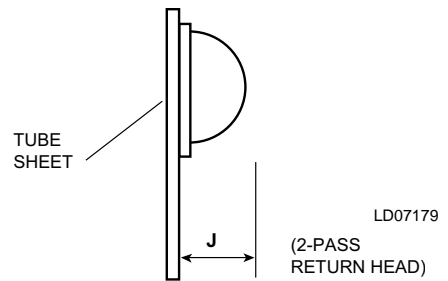
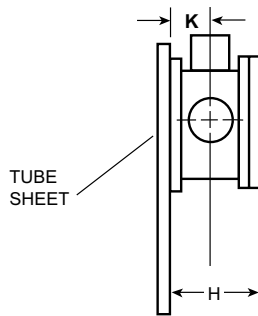

CONDENSER	
2-PASS	
IN	OUT
12	13
17	18

CONDENSER	
3-PASS	
IN	OUT
15	20
19	14

COND SHELL CODE	1-PASS		2-PASS			3-PASS	
	H	K	H	J	K	H	K
A	533	251	425	152	197	425	197
C,D	610	283	495	162	229	495	229
E,F	622	292	565	178	251	565	251
J,K,L	822	391	822	191	391	822	391
M,N	889	406	889	305	406	889	406
P,Q	857	400	813	241	375	743	343
R,S							
T,V,W							
X,Z	1054	470	927	356	413	851	356

NOTES:

1. All dimensions are approximate. Certified dimensions are available upon request.
2. Standard water nozzles are Schedule 40 pipe size, furnished as welding stub-outs with Victaulic grooves, allowing the option of welding, flanges, or use of Victaulic couplings. Factory-installed, class 150 (ANSI B16.5, round slip-on, forged carbon steel with 1.6 mm raised face), water flanged nozzles are optional (add 13 mm to nozzle length). Companion flanges, nuts, bolts, and gaskets are not furnished.
3. One-, two-, and three-pass nozzle arrangements are available only in pairs shown and for all shell codes. Any pair of evaporator nozzles may be used in combination with any pair of condenser nozzles. Compact water boxes on one heat exchanger may be used with Marine Water Boxes on the other heat exchanger.
4. Condenser water must enter the water box through the bottom connection for proper operation of the sub-cooler to achieve rated performance.
5. Add dimension "M" as shown on the unit dimension page for the appropriate isolator type.

Weights - SI

TABLE 10 – APPROXIMATE UNIT WEIGHT INCLUDING MOTOR*

Shells	Compressor	Shipping Weight (kgs.)	Operating Weight (kgs.)	Est. Refrigerant Charge (kgs.)
A-A	Q3	5,942	6,804	367
C-C	Q3, Q4	6,768	8,138	562
C-C	Q5	6,954	8,324	562
D-D	Q3, Q4	7,809	9,571	762
D-D	Q5	7,995	9,757	762
E-E	Q3, Q4	8,142	10,052	776
E-E	Q5,Q6,Q7,P7	8,328	10,238	776
F-F	Q5,Q6,Q7,P7	8,491	10,832	987
G-E	P8	9,208	10,977	903
H-F	P8,P9	10,478	12,701	1,184
J-J	P8,P9	10,886	13,200	1,157
L-L	P8,P9	12,429	15,377	1,436
K-K	H9	12,941	16,329	1,327
K-K	K1	0	0	1,327
M-M	H9	15,513	19,777	1,662
M-M	K1,K2	17,373	21,364	1,662
N-N	K1,K2	18,549	23,043	1,916
N-N	K3	0	0	1,916
P-P	K1,K2	18,824	23,542	1,749
Q-Q	K1,K2	20,548	25,764	1,930
Q-Q	K3	0	0	1,930
R-R	K3	0	0	2,114
R-R	K4	0	0	2,170
S-S	K4	0	0	2,241
S-V	K4	0	0	2,495
X-T	K4	0	0	2,325
X-X	K4	0	0	2,551
W-W	K7	37,467	45,269	3,130
Z-Z	K7	36,968	46,630	2,846

* Refer to product drawings for detailed weight information.

Weights

TABLE 11 EVAPORATOR MARINE WATER BOX WEIGHTS (kgs.)

(To be added to Standard Unit weights shown on Table 10)

Evap. Code	SHIPPING WEIGHT			OPERATING WEIGHT		
	INCREASE - kgs.			INCREASE - kgs.		
	1-Pass	2-Pass	3-Pass	1-Pass	2-Pass	3-Pass
A	419	337	444	666	584	690
C,D	613	505	671	1,009	901	1,067
E,F	852	572	943	1,532	1,252	1,624
G,H	550	588	587	1,204	1,242	1,241
J,K,L	794	836	842	1,753	1,794	1,800
M,N	1,946	924	1,878	3,418	1,481	2,858
P,Q	2,713	1,488	2,596	4,923	2,394	4,283
R,S,W	0	0	0	0	0	0
X,Z	0	0	0	0	0	0

TABLE 12 CONDENSER MARINE WATER BOX WEIGHTS (kgs.)

(To be added to Standard Unit weights shown on Table 10)

Cond. Code	SHIPPING WEIGHT			OPERATING WEIGHT		
	INCREASE - kgs.			INCREASE - kgs.		
	1-Pass	2-Pass	3-Pass	1-Pass	2-Pass	3-Pass
A	346	257	367	578	489	600
C,D	429	353	474	767	691	813
E,F	329	368	359	606	781	772
J,K,L	467	529	522	1,047	1,110	1,103
M,N	1,119	603	1,054	2,206	1,110	2,078
P,Q	1,678	843	1,702	2,976	1,421	2,717
R,S	0	0	0	0	0	0
V,T,W	0	0	0	0	0	0
X,Z	2,649	1,339	2,440	4,491	2,109	3,674

Guide Specifications

GENERAL

Furnish and install where indicated on the drawings _____ YORK MAXE Centrifugal Liquid Chilling Unit(s). Each unit shall produce a capacity _____ of tons, cooling _____ GPM of _____ from _____ °F to _____ °F when supplied with _____ GPM of condenser water at _____ °F. Power input shall not exceed _____ kW with an IPLV (APLV) of _____. The evaporator shall be selected for _____ fouling factor and a maximum liquid pressure drop of _____ ft. Water side shall be designed for 150 PSIG working pressure. The condenser shall be selected for _____ fouling factor and maximum liquid pressure drop of _____ ft. Water-side shall be designed for 150 PSIG working pressure. Power shall be supplied to the compressor motor at _____ volts – 3-phase – (60)(50) Hertz.

(or)

Furnish and install where indicated on the drawings _____ YORK MAXE Centrifugal Liquid Chilling Unit(s). Each unit shall produce a capacity of _____ kW, cooling _____ L/S of _____ from _____ °C to _____ °C when supplied with _____ L/S of condenser water at _____ °C. Power input shall not exceed _____ kW with an IPLV (APLV) of _____. The evaporator shall be selected for _____ m² C/W fouling factor and maximum liquid pressure drop of _____ kPa. Waterside shall be designed for 10.3 bar g working pressure. The condenser shall be selected for _____ fouling factor and maximum liquid pressure drop of _____ kPa. Waterside shall be designed for 10.3 bar g working pressure. Power shall be supplied to the compressor motor at _____ volts – 3-phase – 50 Hertz and controls at 115 volts – 1-phase – 50 Hertz.

Performance shall be certified or rated in accordance with the latest edition of ARI Standard 550/590 as applicable. Only chillers that are listed in the ARI Certification Program for Water Chilling Packages Using the Vapor Compression Cycle are acceptable.

Each unit shall be completely factory-packaged including evaporator, condenser, sub-cooler, compressor, open motor, lubrication system, OptiView Control Center, Variable Speed Drive or Solid State Starter, and all interconnecting unit piping and wiring. The chiller shall be painted prior to shipment.

The initial charge of oil and refrigerant shall be supplied, shipped in containers and cylinders for field installation or factory charged in the chiller.

COMPRESSOR

The compressor shall be a single-stage centrifugal type powered by an open-drive electric motor. The housing shall be fully accessible with vertical circular joints, with the complete operating assembly removable from the com-

pressor and scroll housing. Compressor castings shall be designed for a minimum 235 PSIG working pressure and hydrostatically pressure tested at a minimum of 352 PSIG. The rotor assembly shall consist of a heat-treated alloy steel drive shaft and impeller shaft with a cast aluminum, fully shrouded impeller. The impeller shall be designed for balanced thrust, dynamically balanced and overspeed tested for smooth, vibration-free operation. Insert-type journal and thrust bearings shall be fabricated of aluminum alloy, precision bored and axially grooved.

Internal single helical gears with crowned teeth shall be designed so that more than one tooth is in contact at all times to provide even load distribution and quiet operation. Each gear shall be individually mounted in its own journal and thrust bearings to isolate it from impeller and motor forces. Shaft seal shall be provided in double bellows, double-seal, cartridge type. A gravity-fed oil reservoir shall be built into the top of the compressor to provide lubrication during coastdown in the event of a power failure.

(Fixed Speed Drive) Capacity control shall be achieved by use of pre-rotation vanes to provide fully modulating control from full load to minimum load. (Variable Speed Drive) Capacity control shall be accomplished by the Adaptive Capacity Control (ACC), providing optimal relationship between compressor speed and inlet pre-rotation vane position for maximum energy efficiency. Control shall automatically compensate for adverse operating conditions, such as fouled tubes, and adjust to prior operation after correction of these conditions.

The unit shall be capable of continuous, reliable operation with low ECWT at all load conditions as outlined on the equipment schedule. An external electric actuator shall automatically control pre-rotation vane position.

LUBRICATION SYSTEM

Lubrication oil shall be force-fed to all compressor bearings, gears, and rotating surfaces by an external variable speed oil pump. The oil pump shall vary oil flow to the compressor based on operating and stand-by conditions, ensuring adequate lubrication at all times. The oil pump shall operate prior to start-up, during compressor operation and during coastdown. Compressor shall have an auxiliary reservoir to provide lubrication during coastdown in the event of a power failure.

An oil reservoir, separate from the compressor, shall contain the submersible 2 HP oil pump and a 3000 watt oil heater, thermostatically controlled to remove refrigerant from the oil. The oil reservoir shall be UL listed and shall be factory air strength tested at 1.1 times design working pressure.

Guide Specifications (continued)

Oil shall be filtered by an externally mounted 1/2 micron replaceable cartridge oil filter equipped with service valves. Oil cooling shall be done via a refrigerant cooled oil cooler, with all piping factory-installed. Oil side of the oil cooler shall be provided with service valves. An automatic oil return system to recover any oil that may have migrated to the evaporator shall be provided. Oil piping shall be completely factory-installed and tested.

WATER-COOLED OIL COOLER

Optional condenser water-cooled oil cooler is offered for units with Q3 compressors only. The four tube pass and one shell pass oil cooler is by API Basco, Model 05036 (shell diameter 5" OD, tube length 36"). The shell is steel pipe or tubing and tubesheets are steel to ASME specification. Baffles are precision hot-rolled, punched, carbon steel to assure effective circulation by providing minimum clearances between the tubes and tube holes. The cooler is a straight-tube type and has 180 plain copper tubes of 1/4" OD with 24 BWG. The heat exchanger has either cast iron bonnets to be used for 150 psig condenser water boxes or carbon steel bon-nets to be used for 300 psig condenser water boxes. The water and shell side of the heat exchanger is UL burst pressure tested and certified. Condenser water is the cooling medium and water circulation is obtained by the water pressure drop across the condenser shell. The minimum requirement of 7 to 8 gpm water for this oil cooler is provided at a pressure drop as low as 3ft with the Q3 piping arrangement.

MOTOR DRIVELINE

The compressor motor shall be an open drip-proof, squirrel cage, induction type operating at 3570 rpm (2975 rpm for 50 Hz operation).

The open motor shall be provided with a D-flange, bolted to a cast iron adaptor mounted on the compressor to allow the motor to be rigidly coupled to the compressor to provide factory alignment of motor and compressor shafts.

Motor drive shaft shall be directly connected to the compressor shaft with a flexible disc coupling. Coupling shall have all metal construction with no wearing parts to assure long life, and no lubrication requirements to provide low maintenance. For units utilizing remote electromechanical starters, a large steel terminal box with gasketed front access cover shall be provided for field-connected conduit. Overload/overcurrent transformers shall be furnished with all units. (For units furnished with factory-packaged Solid State Starters or Variable Speed Drive, refer to the "Options" section.)

EVAPORATOR

Evaporator shall be of the shell-and-tube, flooded type

designed for a minimum of 180 PSIG (1241 kPa) on H & K Compressor models, 235 PSIG (1620 kPa) on P & Q Compressor models; working pressure on the refrigerant side. Shell shall be fabricated from rolled carbon steel plates with fusion welded seams, carbon steel tube sheets, drilled and reamed to accommodate the tubes, and intermediate tube supports spaced no more than four feet apart. The refrigerant side of each shell is designed, tested and stamped in accordance with ASME Boiler and Pressure Vessel Code, Section VIII – Division I, or other pressure vessel code as appropriate.

Heat exchanger tubes shall be high-efficiency, externally and internally enhanced type. Tubes shall utilize the "skip-fin" design, providing a smooth internal and external surface at each intermediate tube support. This provides extra wall thickness and non-work hardened copper at the support location, extending the life of the heat exchangers. If skip-fin tubes are not used, minimum tube wall thickness shall be 0.035" (0.889 mm). Each tube shall be roller expanded into the tube sheets providing a leak-proof seal, and be individually replaceable. Water velocity through the tubes shall not exceed 12 ft./sec. (3.65 m/sec). A liquid level sight glass shall be provided on the side of the shell to aid in determining proper refrigerant charge and to check condition of the refrigerant charge. A suction baffle or aluminum mesh eliminators shall be located above the tube bundle to prevent liquid refrigerant carryover to the compressor. The evaporator shall have a refrigerant relief device sized to meet the requirements of the ASHRAE 15 Safety Code for Mechanical Refrigeration.

Water boxes shall be removable to permit tube cleaning and replacement. Stub-out water connections having Victaulic grooves to ANSI/AWWA C-606 Standard for Grooved End Shoulder Joints shall be provided. Water boxes shall be designed for 150 PSIG (1034 kPa) design working pressure and be tested at 225 PSIG (1551 kPa). Vent and drain connections with plugs shall be provided on each water box. Low flow protection shall be provided by a thermal-type water flow sensor, factory mounted in the water nozzle connection and wired to the chiller control panel.

CONDENSER

Condenser shall be of the shell-and-tube type, designed for a minimum of 235 PSIG (1620 kPa) working pressure on the refrigerant side. Shell shall be fabricated from rolled carbon steel plates with fusion welded seams. Carbon steel tube sheets, drilled and reamed to accommodate the tubes, are welded to the end of each shell. Intermediate tube supports are drilled and reamed to eliminate sharp edges, fabricated from carbon steel plates. The refrigerant side of each shell is designed, tested and stamped in accordance with ASME Boiler and Pressure Vessel Code,

Section VIII – Division I, or other pressure vessel code as appropriate.

Heat exchanger tubes shall be high efficiency, externally and internally enhanced type. Tubes shall utilize the “skip-fin” design, providing a smooth internal and external surface at each intermediate tube support. This provides extra wall thickness and non-work hardened copper at the support location, extending the life of the heat exchangers. If skip-fin tubes are not used, minimum tube wall thickness shall be 0.035" (0.889 mm). Each tube shall be roller expanded into the tube sheets providing a leak-proof seal, and be individually replaceable. Water velocity through the tubes shall not exceed 12 ft./sec. (3.65 m/sec.). A liquid level sight glass shall be provided on the side of the shell to aid in determining proper refrigerant charge and to check condition of the refrigerant charge. The condenser shall have dual refrigerant relief devices; each sized to meet the requirements of the ASHRAE 15 Safety Code for Mechanical Refrigeration. Arrangement shall allow either valve to be isolated and replaced without removing the unit refrigerant charge.

(Option) The condenser shall be provided with positive shutoff valves in the compressor discharge line to the condenser and in the liquid line leaving the condenser. This will allow pumpdown and storage of the refrigerant charge in the condenser. Due to the possibility of not seating properly, check valves are not acceptable for isolation purposes. If a check valve is used, a positive shutoff valve must be provided in series with the check valve.

Water boxes shall be removable to permit tube cleaning and replacement. Stubout water connections having Victaulic grooves shall be provided. Water boxes shall be designed for 150 PSIG (1034 kPa) design working pressure and be tested at 225 PSIG (1551 kPa). Vent and drain connections with plugs shall be provided on each water box.

REFRIGERANT FLOW CONTROL

Refrigerant flow to the evaporator shall be controlled by a variable orifice. The variable orifice control shall automatically adjust to maintain proper refrigerant level in the condenser and evaporator. This shall be controlled by monitoring refrigerant liquid level in the condenser, assuring optimal subcooler performance.

OPTIVIEW CONTROL CENTER

General – The chiller shall be controlled by a stand-alone microprocessor based control center. The chiller control panel shall provide control of chiller operation and monitoring of chiller sensors, actuators, relays and switches.

Control Panel – The control panel shall include a 10.4-in. diagonal color liquid crystal display (LCD) surrounded

by “soft “ keys which are redefined based on the screen displayed at that time. This shall be mounted in the middle of a keypad interface and installed in a locked enclosure. The screen shall detail all operations and parameters, using a graphical representation of the chiller and its major components. The panel verbiage is available in eight languages as standard and can be changed on the fly without having to turn off the chiller. Data shall be displayed in either English or Metric units. Smart Freeze Point Protection shall run the chiller at 36°F (2.2°C) leaving chilled water temperature, and not have nuisance trips on low water temperature. The sophisticated program and sensor shall monitor the chiller water temperature to prevent freeze-up. When needed, Hot Gas Bypass is available as an option. The panel shall display countdown timer messages so the operator knows when functions are starting and stopping. Every programmable point shall have a pop-up screen with the allowable ranges, so that the chiller can not be programmed to operate outside of its design limits.

The chiller control panel shall also provide:

1. System operating information including:
 - a. return and leaving chilled water temperature
 - b. return and leaving condenser water temperature
 - c. evaporator and condenser saturation temperature
 - d. differential oil pressure
 - e. percent motor current
 - f. compressor discharge temperature
 - g. oil reservoir temperature
 - h. compressor thrust bearing positioning and oil temperature
 - i. operating hours
 - j. number of unit starts
2. Digital programming of setpoints through the universal keypad including:
 - a. leaving chilled water temperature
 - b. percent current limit
 - c. pull-down demand limiting
 - d. six-week schedule for starting and stopping the chiller, pumps and tower
 - e. remote reset temperature range
3. Status messages indicating:
 - a. system ready to start
 - b. system running

Guide Specifications (continued)

- c. system coastdown
 - d. system safety shutdown – manual restart
 - e. system cycling shutdown – auto restart
 - f. system prelube
 - g. start inhibit
4. The text displayed within the system status and system details field shall be displayed as a color-coded message to indicate severity: red for safety fault, orange for cycling faults, yellow for warnings, and green for normal messages.
5. Safety shutdowns enunciated through the display and the status bar, and consist of system status, system details, day, time, cause of shutdown, and type of restart required. Safety shutdowns with a fixed speed drive shall include:
- a. evaporator – low pressure
 - b. evaporator – transducer or leaving liquid probe
 - c. evaporator – transducer or temperature sensor
 - d. condenser – high pressure contacts open
 - e. condenser – high pressure
 - f. condenser – pressure transducer out-of-range
 - g. auxiliary safety – contacts closed
 - h. discharge – high temperature
 - i. discharge – low temperature
 - j. oil – high temperature
 - k. oil – low differential pressure
 - l. oil – high differential pressure
 - m. oil – sump pressure transducer out-of-range
 - n. oil – differential pressure calibration
 - o. oil – variable speed pump – pressure setpoint not achieved
 - p. control panel – power failure
 - q. motor or starter – current imbalance
 - r. thrust bearing – proximity probe clearance (K compressors only)
 - s. thrust bearing – proximity probe out-of-range (K compressors only)
 - t. thrust bearing – position switch (P, Q & H9 compressors)
 - u. watchdog – software reboot
- 5.1 Safety shutdowns with a VSD shall include:
- a. VSD shutdown – requesting fault data
 - b. VSD – stop contacts open
- c. VSD – 105% motor current overload
 - d. VSD – high phase A, B, C inverter heatsink temp.
 - e. VSD – high converter heatsink temperature
- (Filter Option Only)
- f. harmonic filter – high heatsink temperature
 - g. harmonic filter – high total demand distribution
6. Cycling shutdowns enunciated through the display and the status bar, and consists of system status, system details, day, time, cause of shutdown, and type of restart required.
- Cycling shutdowns with a fixed speed drive shall include:
- a. multi-unit cycling – contacts open
 - b. system cycling – contacts open
 - c. oil – low temperature differential
 - d. oil – low temperature
 - e. control panel – power failure
 - f. leaving chilled liquid – low temperature
 - g. leaving chilled liquid – flow switch open
 - h. motor controller – contacts open
 - i. motor controller – loss of current
 - j. power fault
 - k. control panel – schedule
 - l. starter – low supply line voltage (SSS option)
 - m. starter – high supply line voltage (SSS option)
 - n. proximity probe – low supply voltage (K compressors)
 - o. oil – variable speed pump – drive contacts open
- 6.1 Cycling shutdowns with a VSD shall include:
- a. VSD shutdown – requesting fault data
 - b. VSD – stop contacts open
 - c. VSD – initialization failed
 - d. VSD – high phase A, B, C instantaneous current
 - e. VSD – phase A, B, C gate driver
 - f. VSD – single phase input power
 - g. VSD – high DC bus voltage
 - h. VSD – pre charge DC bus voltage imbalance
 - i. VSD – high internal ambient temperature
 - j. VSD – invalid current scale selection
 - k. VSD – low phase A, B, C inverter heatsink temp.
 - l. VSD – low converter heatsink temperature

- m. VSD – pre-charge – low DC bus voltage
- n. VSD – logic board processor
- o. VSD – run signal
- p. VSD – serial communications

(Filter Option Only)

- q. harmonic filter – logic board or communications
- r. harmonic filter – high DC bus voltage
- s. harmonic filter – high phase A, B, C current
- t. harmonic filter – phase locked loop
- u. harmonic filter – precharge – low DC bus voltage
- v. harmonic filter – DC bus voltage imbalance
- w. harmonic filter – 110% input current overload
- x. harmonic filter – logic board power supply
- y. harmonic filter – run signal
- z. harmonic filter – DC current transformer 1
- aa. harmonic filter – DC current transformer 2

7. Security access to prevent unauthorized change of setpoints, to allow local or remote control of the chiller, and to allow manual operation of the pre-rotation vanes and oil pump. Access shall be through ID and password recognition, which is defined by three different levels of user competence: view, operator, and service.
8. Trending data with the ability to customize points of once every second to once every hour. The panel shall trend up to 6 different parameters from a list of over 140, without the need of an external monitoring system.
9. The operating program stored in non-volatile memory (EPROM) to eliminate reprogramming the chiller due to AC power failure or battery discharge. Programmed setpoints shall be retained in lithium battery-backed RTC memory for a minimum of 11 years with power removed from the system.
10. A fused connection through a transformer in the compressor motor starter to provide individual over-current protected power for all controls.
11. A numbered terminal strip for all required field interlock wiring.

12. An RS-232 port to output all system operating data, shutdown/cycling message, and a record of the last 10 cycling or safety shutdowns to a field-supplied printer. Data logs to a printer at a set programmable interval. This data can be preprogrammed to print from 1 minute to 1 day.

13. The capability to interface with a building automation system via hard-wired connections to each feature to provide:
 - a. remote chiller start and stop
 - b. remote leaving chiller liquid temperature adjust
 - c. remote current limit setpoint adjust
 - d. remote ready to start contacts
 - e. safety shutdown contacts
 - f. cycling shutdown contacts
 - g. run contacts

VARIABLE SPEED DRIVE

A variable speed drive shall be factory-installed on the chiller. It shall vary the compressor motor speed by controlling the frequency and voltage of the electrical power to the motor. The adaptive capacity control logic shall automatically adjust motor speed and compressor pre-rotation vane position independently for maximum part load efficiency by analyzing information fed to it by sensors located throughout the chiller.

Drive shall be PWM type utilizing IGBTs with a power factor of 0.95 or better at all loads and speeds.

The variable speed drive shall be unit-mounted in a NEMA-1 enclosure with all power and control wiring between the drive and chiller factory-installed, including power to the chiller oil pump. Field power wiring shall be a single-point connection and electrical lugs for incoming power wiring shall be provided. The entire chiller package shall be U.L. listed.

The variable speed drive is cooled by a closed loop, fresh water circuit consisting of a water-to-water heat exchanger and circulating pump. All interconnecting water piping is factory installed and rated for 150 PSIG working pressure.

The following features shall be provided: a door interlocked circuit breaker, capable of being padlocked; U.L. listed ground fault protection; overvoltage and undervoltage protection; 3-phase sensing motor overcurrent protection; single phase protection; insensitive to phase

Guide Specifications (continued)

rotation; overtemperature protection; digital readout at the chiller unit control panel of:

- Output Frequency
- Output Voltage
- 3-phase output current
- Input Kilowatts (kW) and Kilowatt-hours (kWH)
- Self diagnostic service parameters

Separate meters for this information shall not be acceptable.

(Optional) A harmonic filter that limits electrical power supply distortion for the variable speed drive to comply with the guidelines of IEEE Std. 519-1992 shall be provided. The filter shall be unit mounted within the same NEMA-1 enclosure and shall be U.L. listed. The following digital readouts shall be provided at the chiller unit control panel as part of the filter package:

- Input KVA
- Total power factor
- 3-phase input voltage
- 3-phase input current
- 3-phase input voltage total harmonic distortion (THD)
- 3-phase input current total demand distortion (TDD)
- Self diagnostic service parameters

Separate meters for this information shall not be acceptable.

FACTORY-INSTALLED COMPRESSOR MOTOR STARTER [OPTION THROUGH 900 HP (671.1 kW) 200-600 VOLTS]

The chiller manufacturer shall furnish a reduced-voltage Solid State Starter for the compressor motor. Starter shall be factory-mounted and wired on the chiller. The starter shall provide, through the use of silicon controlled rectifiers, a smooth acceleration of the motor without current transitions or transients. The starter enclosure shall be NEMA 1, with a hinged access door with lock and key. Electrical lugs for incoming power wiring shall be provided.

Standard Features include: digital readout at the OptiView Control Center of the following:

Display Only

- 3-phase voltage A, B, C
- 3-phase current A, B, C
- Input Power (kW)
- kW Hours
- Starter Model
- Motor Run (LED)

- Motor Current % Full Load Amps
- Current Limit Setpoints
- Pulldown Demand Time Left

Programmable

- Local Motor Current Limit
- Pulldown Demand Limit
- Pulldown Demand Time

Other features include: low line voltage; 115-volt control transformer; three-leg sensing overloads; phase rotation and single-phase failure protection; high temperature safety protection; motor current imbalance and undervoltage safeties; open and close SCR protection; momentary power interruption protection. The Solid State Starter is cooled by a closed loop, fresh water circuit consisting of a water-to-water heat exchanger and circulating pump. All interconnecting water piping is factory-installed and rated for 150 PSIG working pressure.

Optional: Unit-mounted circuit breaker includes ground fault protection and provides 65,000 amp. Short circuit withstand rating in accordance with U.L. Standard 508. A non-fused disconnect switch is also available. Both options are padlockable.

REMOTE ELECTRO-MECHANICAL COMPRESSOR MOTOR STARTER (OPTION)

A remote electro-mechanical starter of the R-1132 type shall be furnished for each compressor motor. The starter shall be furnished in accordance with the chiller manufacturer's starter specifications and as specified elsewhere in these specifications.

PORTABLE REFRIGERANT STORAGE / RECYCLING SYSTEM

A portable, self-contained refrigerant storage/recycling system shall be provided consisting of a refrigerant compressor with oil separator, storage receiver, water-cooled condenser, filter drier and necessary valves and hoses to remove, replace and distill refrigerant. All necessary controls and safety devices shall be a permanent part of the system.

SI Metric Conversion

Values provided in this manual are in the English inch-pound (I-P) system.

The following factors can be used to convert from English to the most common SI Metric values.

MEASUREMENT	MULTIPLY THIS ENGLISH VALUE	BY	TO OBTAIN THIS METRIC VALUE
CAPACITY	TONS REFRIGERANT EFFECT (ton)	3.516	KILOWATTS (kW)
POWER	KILOWATTS (kW)	NO CHANGE	KILOWATTS (kW)
	HORSEPOWER (hp)	0.7457	KILOWATTS (kW)
FLOW RATE	GALLONS / MINUTE (gpm)	0.0631	LITERS / SECOND (L/s)
LENGTH	FEET (ft)	304.8	MILLIMETERS (mm)
	INCHES (in)	25.4	MILLIMETERS (mm)
WEIGHT	POUNDS (lb)	0.4536	KILOGRAMS (kg)
VELOCITY	FEET / SECOND (fps)	0.3048	METERS / SECOND (m/s)
PRESSURE DROP	FEET OF WATER (ft)	2.989	KILOPASCALS (kPa)
	POUNDS / SQ. INCH (psi)	6.895	KILOPASCALS (k Pa)

TEMPERATURE

To convert degrees Fahrenheit (°F) to degrees Celsius (°C), subtract 32° and multiply by 5/9 or 0.5556.

To convert a temperature range (i.e., 10°F or 12°F chilled water range) from Fahrenheit to Celsius, multiply by 5/9 or 0.5556.

EFFICIENCY

In the English I-P system, chiller efficiency is measured in kW / ton:

$$\text{kW / ton} = \frac{\text{kW input}}{\text{tons refrigerant effect}}$$

In the SI Metric system, chiller efficiency is measured in Coefficient of Performance (COP).

$$\text{COP} = \frac{\text{kW refrigeration effect}}{\text{kW input}}$$

kW / ton and COP are related as follows:

$$\text{kW/ton} = \frac{3.516}{\text{COP}}$$

$$\text{COP} = \frac{3.516}{\text{kW/ton}}$$

FOULING FACTOR

ENGLISH I-P (ft ² °F hr/Btu)	EQUIVALENT SI METRIC (m ² k/kW)
0.0001	.018
0.00025	.044
0.0005	.088
0.00075	.132



THIS PAGE INTENTIONALLY LEFT BLANK

THIS PAGE INTENTIONALLY LEFT BLANK



P. O. Box 1592, York, Pennsylvania USA 17504-1592
© by Johnson Controls 2006

Tel: 800-451-1001
www.york.com

Subject to change without notice. Printed in USA
ALL RIGHTS RESERVED

Form 160.75-EG1 (507)
Supersedes: 160.75-EG1 (307)