



The world's largest privately owned HVAC distributor

1.5 TO 5 TONS YORK COOLING ONLY CONDENSING UNITS

HRD 13 SEER R-22 Three Phase (2.5 to 5 tons)

have the following available benefits and options

Please specify the following:

- Micro Channel Condenser Coil
- High/Low Pressure switch, Internal Protections
- Factory Installed Filter Drier
- Isolated Compressor Compartment
- Low Sound Operation with Low RPM Fans
- 5 Years Parts Warranty
- 10 Years Compressor Warranty
- Choice of colors to match building
- T2950 365 Days Thermostat
- BAS Networkable with free Web Software
- ArmorGuard Stainless Steel 316 Corrosion Protection on coils

Please call us!

Samy Rezine
Karine Leblanc
Maher Syada
Michelle Sangalang

310-420-6767
310-420-7066
626-255-6406
626-854-4613

samy@rezine.net
karine@rezine.net
maher@rezine.net
michelle@rezine.net



TECHNICAL GUIDE

SPLIT-SYSTEM AIR CONDITIONERS

13 SEER – R-22

**H*RD036 THRU 060
(2.5 THRU 5 NOMINAL TONS, 3 PHASE)**



Due to continuous product improvement, specifications are subject to change without notice.

Visit us on the web at www.york.com

Additional rating information can be found at www.ari.org/ariDirectory

DESCRIPTION

The 13 SEER Series condensing unit is the outdoor part of a versatile system of air conditioning. It is designed to be custom-matched with one of UPG's complete line of evaporator sections, with each serving a specific function. Matching Air Handlers are available for upflow, downflow, or horizontal applications to provide a complete system. Electric Heaters are available, if required. Add-On coils are available for use with upflow, downflow, or horizontal furnaces and air handlers.

WARRANTY

Single Phase Units:

5-year limited parts warranty.

5-year limited compressor warranty.

Three Phase Units:

1-year limited parts warranty.

5-year limited compressor warranty.

FEATURES

- **QUALITY CONDENSER COILS** - The coil is constructed of copper tube and aluminum fins.
- **PROTECTED COMPRESSOR** - The compressor is internally protected against high pressure and temperature. This is accomplished by the simultaneous operation of high pressure relief valve and a temperature sensor which protects the compressor if undesirable operating conditions occur. A liquid line filter-drier further protects the compressor.
- **DURABLE FINISH** - The cabinet is made of pre-painted steel. The pre-treated galvanized steel provides a better paint to steel bond, which resists corrosion and rust creep. Special primer formulas and matted-textured finish insure less fading when exposed to sunlight.
- **LOWER INSTALLED COST** - Installation time and costs are reduced by easy power and control wiring connections. Discharge line heat exchanger knockouts are provided, if required. Available in sweat connect models only. The unit contains enough refrigerant for matching indoor coils and 15 feet of interconnecting piping. The small base dimension means less space is required on the ground or roof.
- **TOP DISCHARGE** - The warm air from the top mounted fan is blown up away from the structure and any landscaping. This allows compact location on multi-unit applications.
- **LOW OPERATING SOUND LEVEL** - The upward air flow carries the normal operating noise away from the living area. The rigid top panel effectively isolates any motor sound. Isolator mounted compressor and the rippled fins of the condenser coil muffle the normal fan motor and compressor operating sounds.
- **LOW MAINTENANCE** - Long life permanently lubricated motor-bearings need no annual servicing.
- **EASY SERVICE ACCESS** - Fully exposed refrigerant connections, a single panel covering the electrical controls, and the molex plug in the control box connecting the condenser fan make for easy servicing of the unit.
- **SECURED SERVICE VALVES** - Secured re-usable service valves are provided on both the liquid and vapor sweat connections for ease of evacuating and charging.
- **U.L. and C.U.L. listed** - approved for outdoor application.

Certified in accordance with the Unitary Small Equipment certification program, which is based on ARI Standard 210/240.

FOR DISTRIBUTION USE ONLY - NOT TO BE USED AT POINT OF RETAIL SALE

PHYSICAL AND ELECTRICAL DATA - 3 PHASE

MODEL	H1RD 030S25	H1RD 036S25	H1RD 042S25	H1RD 048S25	H1RD 060S25	H1RD 030S46	H1RD 036S46	H1RD 042S46	H1RD 048S46	H1RD 060S46	
Unit Supply Voltage	208-230V, 3 ϕ , 60Hz					460V, 3 ϕ , 60Hz					
Normal Voltage Range ¹	187 to 252					432 to 504					
Minimum Circuit Ampacity	14.3	14.3	12.4	21.5	23.1	6.9	9.6	6.9	10.3	11.3	
Max. Overcurrent Device Amps ²	20	20	20	35	40	15	15	15	15	15	
Min. Overcurrent Device Amps ³	15	15	15	25	25	15	15	15	15	15	
Compressor Type ⁴	Recip	Recip	Recip	Scroll ^D	Scroll ^D	Recip	Recip	Recip	Scroll ^D	Scroll ^D	
Compressor Amps	Rated Load	10.2	10.2	8.8	16.0	17.3	4.9	4.9	4.9	7.7	8.4
	Locked Rotor	72	72	72	115	123	45	45	45	50	70
Crankcase Heater	No	No	No	No	No	No	No	No	No	No	
Fan Motor Amps	Rated Load	1.5	1.5	1.5	1.5	1.5	0.7	0.7	0.7	0.7	
Fan Diameter Inches	22	22	22	22	24	22	22	22	24	24	
Fan Motor	Rated HP	1/4	1/4	1/4	1/4	1/4	1/4	1/4	1/4	1/4	
	Nominal RPM	850	850	850	850	850	850	850	850	850	
	Nominal CFM	3100	3150	3550	3550	3600	3100	3150	3550	3550	3600
Coil	Face Area Sq. Ft.	15.72	15.72	23.60	24.00	27.00	15.72	15.72	23.60	24.00	27.00
	Rows Deep	1	1	1	1	1	1	1	1	2	2
	Fin / Inches	22	22	22	22	22	22	22	22	18	18
Liquid Line Set OD (Field Installed)	3/8	3/8	3/8	3/8	3/8	3/8	3/8	3/8	3/8	3/8	
Vapor Line Set OD (Field Installed)	3/4	7/8	7/8	7/8	1-1/8	3/4	7/8	7/8	7/8	1-1/8	
Unit Charge (Lbs. - Oz.) ⁵	5 - 13	6 - 0	8 - 13	8 - 6	10 - 2	5 - 13	6 - 0	8 - 13	8 - 6	10 - 2	
Charge Per Foot, Oz.	0.68	0.70	0.70	0.70	0.76	0.68	0.70	0.70	0.70	0.76	
Operating Weight Lbs.	208	208	208	215	294	208	208	215	250	294	

1. Rated in accordance with ARI Standard 110, utilization range "A".
2. Dual element fuses or HACR circuit breaker. Maximum allowable overcurrent protection.
3. Dual element fuses or HACR circuit breaker. Minimum recommended overcurrent protection.
4. All scrolls listed with a superscript "D" are Danfoss scrolls. All scrolls listed with a superscript "C" are Copeland scrolls.
5. The Unit Charge is correct for the outdoor unit, matched indoor coil and 15 feet of refrigerant tubing. For tubing lengths other than 15 feet, add or subtract the amount of refrigerant, using the difference in length multiplied by the per foot value.

All dimensions are in inches. They are subject to change without notice. Certified dimensions will be provided upon request.

DIMENSIONS

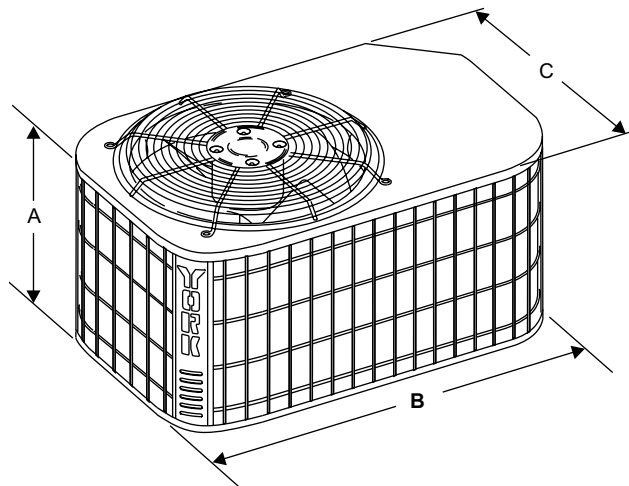

Unit Model	Dimensions (Inches)			Refrigerant Connection Service Valve Size	
	A ¹	B	C	Liquid	Vapor
030	27	37	27	3/8"	3/4"
036	27	37	27		7/8"
042	39	37	27		7/8"
048	34	43	32		7/8"
060	38	43	32		7/8"

1. Including Fan Guard.
- * Adapter fitting required for 1-1/8" line set.

COOLING CAPACITY - With Air Handler Coils								
UNIT MODEL	AIR HANDLER		COIL MODEL ¹	RATED CFM	COOLING		SEER	EER
	MODEL	W			NET MBH			
					TOTAL	SENS.		
HIRD 3 PH 13 SEER AC WITH AHP								
H1RD030S(25,46)	AHP30	17	–	1015	29.7	21.7	13	11
	AHP36	17	–	1040	29.7	22.4	13.5	11
H1RD036S(25,46)	AHP36	17	–	1235	34.7	27	13.5	11
	AHP42	21	–	1255	34.7	27.3	13.5	11
	AHP60	24	–	1200	35.7	26.5	14	11.5
H1RD042S(25,46)	AHP42	21	–	1485	40	30.3	13	11
	AHP48	24	–	1400	41	30	13.5	11
	AHP60	24	–	1400	39.5	32.5	14	11.5
H1RD048S(25,46)	AHP48	24	–	1675	46	36.1	13	11
	AHP60	24	–	1600	46	35.5	13.75	11
H1RD060S(25,46)	AHP60	24	–	1850	54	39.6	13	11

Rated in accordance with DOE test procedures (Federal Register 12-27-79 and 3-18-88) and ARI Standards 210. Cooling MBH based on 80°F entering air temperature, 50% RH, and rated air flow. EER (Energy Efficiency Ratio) is the total cooling output in BTU's at 95°F outdoor ambient divided by the total electric power SEER (Seasonal Energy Efficiency Ratio) is the total cooling output in BTU's during a normal annual usage period for coinput in watt-hours during the same period.

COOLING CAPACITY - Upflow, Downflow & Horizontal Furnaces and Coils								
UNIT MODEL	FURNACE		COIL MODEL	RATED CFM	COOLING		SEER	EER
	Model #	W			NET MBH			
					TOTAL	SENS.		
H1RD030S(25,46)	PM/PC9	14,17	FC30	1000	29	20.9	13	11
		14,17,21	FC36	1000	29	20.9	13	11
		14	HC30	1000	29	20.9	13	11
		17	HC36	1000	29	20.9	13	11
H1RD036S(25,46)	PM/PC9	14,17,21	FC36	1200	34.5	25.2	13	11
		17	HC36	1200	34.7	25.4	13	11
H1RD042S(25,46)	PM/PC9	17,21	FC42	1400	39.5	28.9	13	11
		21,24	FC48	1400	40	29.5	13	11
		21	HC42	1400	40	29.2	13	11
H1RD048S(25,46)	PM/PC9	21,24	FC48	1600	46	34.4	13	11
H1RD060S06	PM/PC9	21,24	FC60	1800	55	39.6	13	11
		24	HC60	1800	55	39.6	13	11

Rated in accordance with DOE test procedures (Federal Register 12-27-79 and 3-18-88) and ARI Standards 210. Cooling MBH based on 80°F entering air temperature, 50% RH, and rated air flow. EER (Energy Efficiency Ratio) is the total cooling output in BTU's at 95°F outdoor ambient divided by the total electric power SEER (Seasonal Energy Efficiency Ratio) is the total cooling output in BTU's during a normal annual usage period for coinput in watt-hours during the same period.

ACCESSORIES

Refer to Price Manual for specific model numbers.

HARD START KIT - Provides increased starting torque for areas with low voltage.

COMPRESSOR BLANKET - Designed to further reduce the normal compressor operating sound. Refer to price pages for specific match-ups.

OFF CYCLE TIMER DELAY - Provides a 5-minute off cycle to prevent rapid recycling of the compressor.

ROOM THERMOSTATS - A wide selection of compatible thermostats are available to provide optimum performance and features for any installation.

1H/1C, manual changeover electronic non-programmable thermostat.

1H/1C, auto/manual changeover, electronic programmable, deluxe 7-day, thermostat.

1H/1C, auto/manual changeover, electronic programmable.

* For the most current accessory information, refer to the price book or consult factory.

SOUND POWER RATINGS*

UNIT MODEL	(dBA)
018	75
024	74
030	75
036	75
042	76
048	76
060	76

* Rated in accordance with ARI 270-95 Standards.

TYPICAL INSTALLATION

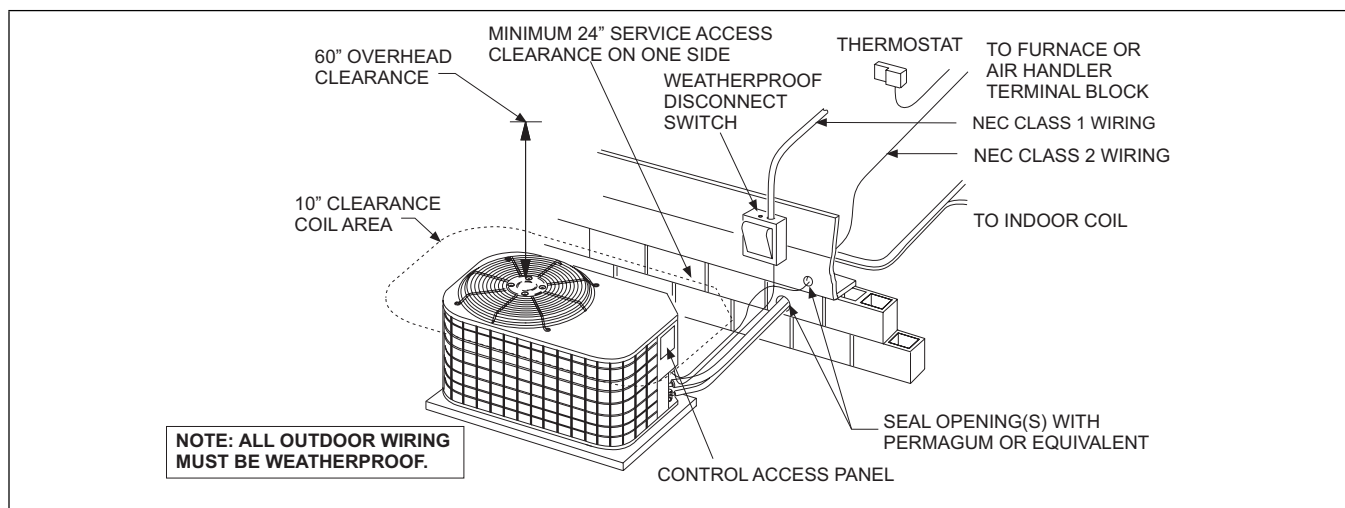

TYPICAL FIELD WIRING - 1 Phase Application

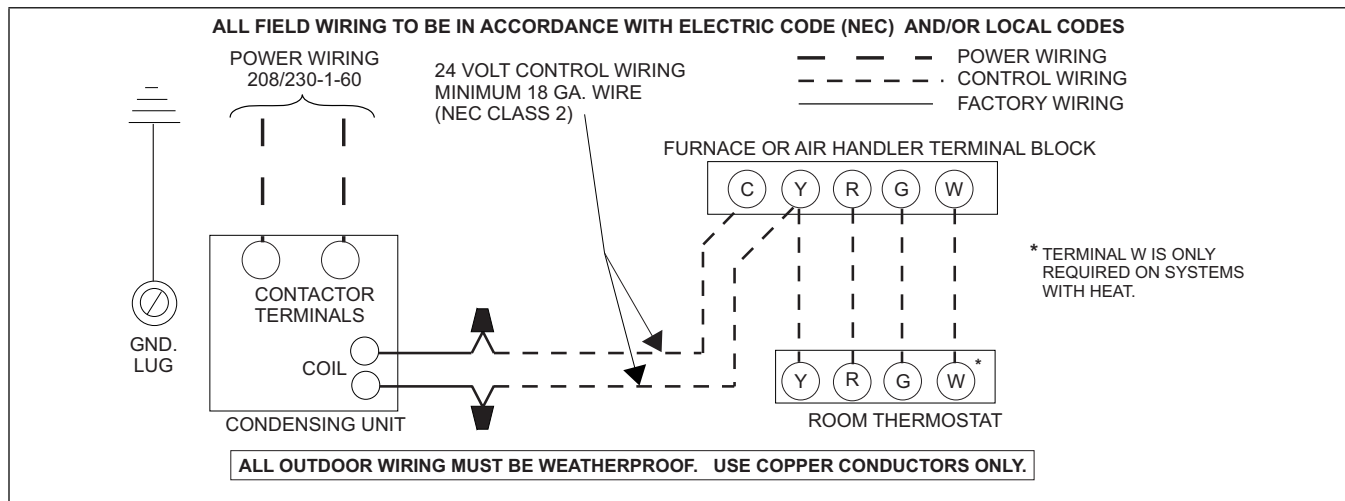

COOLING PERFORMANCE DATA																
AIR CONDITIONER MODEL NO.		H2RD030S06 , H1RD030S(25,46) **														
INDOOR COIL MODEL NO.		FC/MC/PC/UC30														
CONDENSING ENTERING AIR TEMPERATURE	IDCFM	800					1000					1200				
	ID DB (°F)	80	80	75	80	80	80	80	75	80	80	80	80	75	80	80
	ID WB (°F)	57	62	62	67	72	57	62	62	67	72	57	62	62	67	72
65	T.C.	27.0	31.8	30.1	33.7	35.6	29.0	33.4	31.3	35.1	36.7	31.1	35.0	32.6	36.5	37.7
	S.C.	26.9	24.7	20.6	21.2	16.0	29.0	27.7	22.9	23.4	17.7	31.1	30.7	25.2	25.6	19.5
	KW	1.8	1.8	1.8	1.8	1.8	1.8	1.8	1.8	1.8	1.8	1.8	1.8	1.8	1.8	1.8
75	T.C.	25.9	30.3	28.7	32.1	33.6	27.9	31.9	29.9	33.4	34.5	29.8	33.5	31.1	34.7	35.4
	S.C.	25.9	24.2	20.0	20.5	15.6	27.8	27.0	22.3	22.7	17.2	29.8	29.8	24.5	24.9	18.8
	KW	1.9	1.9	1.9	2.0	2.0	1.9	1.9	1.9	2.0	2.0	2.0	1.9	2.0	2.0	2.0
85	T.C.	24.9	28.8	27.2	30.4	31.7	26.7	30.4	28.4	31.7	32.4	28.6	32.0	29.6	32.9	33.1
	S.C.	24.9	23.7	19.5	19.7	15.2	26.7	26.3	21.7	21.9	16.7	28.5	28.9	23.9	24.1	18.1
	KW	2.1	2.1	2.1	2.1	2.1	2.1	2.1	2.1	2.1	2.2	2.1	2.1	2.1	2.1	2.2
95	T.C.	23.8	27.4	25.8	28.7	29.7	25.6	28.9	26.9	30.0	30.2	27.3	30.5	28.1	31.2	30.7
	S.C.	23.8	23.2	18.9	18.9	14.8	25.5	25.6	21.1	21.2	16.2	27.3	28.1	23.3	23.4	17.5
	KW	2.2	2.2	2.2	2.3	2.3	2.2	2.2	2.2	2.3	2.3	2.3	2.3	2.2	2.3	2.3
105	T.C.	22.8	25.9	24.3	27.1	27.8	24.4	27.5	25.3	28.2	28.2	26.0	29.1	26.4	29.3	28.5
	S.C.	22.7	22.4	18.3	18.3	14.1	24.3	24.5	20.4	20.5	15.4	25.9	26.5	22.6	22.6	16.6
	KW	2.4	2.4	2.4	2.4	2.5	2.4	2.4	2.4	2.4	2.5	2.4	2.4	2.4	2.5	2.5
115	T.C.	21.8	24.5	22.8	25.5	25.9	23.2	26.1	23.7	26.5	26.1	24.7	27.8	24.7	27.4	26.4
	S.C.	21.7	21.6	17.6	17.7	13.5	23.2	23.3	19.7	19.8	14.6	24.7	25.0	21.8	21.9	15.8
	KW	2.5	2.5	2.5	2.6	2.6	2.6	2.5	2.5	2.6	2.7	2.6	2.6	2.5	2.6	2.7
125	T.C.	20.8	23.0	21.3	23.9	24.0	22.1	24.8	22.2	24.7	24.1	23.4	26.5	23.0	25.6	24.3
	S.C.	20.6	20.9	17.0	17.1	12.8	22.0	22.2	19.0	19.1	13.9	23.4	23.5	21.1	21.1	15.1
	KW	2.7	2.7	2.6	2.7	2.8	2.7	2.7	2.7	2.7	2.8	2.8	2.7	2.7	2.8	2.8

NOTE: ALL CAPACITIES INCLUDE INDOOR FAN HEAT AT 1250 BTUH/1000 CFM.
****** For three-phase, decrease T.C. by 0.6 and S.C. by 0.3.

Multipliers for determining the performance with other indoor sections.

NOTE: For dry bulb temperatures different than those listed (between 73-87 F), sensible capacity increases by 1060 BTUH per 1000 CFM per degree above the listed temperature and decreases by 1060 BTUH per 1000 CFM per degree below the listed temperature.

Air Handler	Coil	T.C.	S.C.	KW
MA12B	MC30B	1.00	1.00	1.00
MA12B	MC36B	1.00	1.01	1.00
AHP30	-	1.01	1.04	1.01
AHP36	-	1.01	1.08	1.01
F*FP036	-	1.00	1.01	1.00
MV12B*	FC/MC30B	1.01	1.00	0.97
MV12B*	FC/MC36B	1.01	1.01	0.97
MV16C*	FC/MC36C	1.01	1.01	0.97
AV36*	-	1.01	1.01	0.97
-	FC/MC/PC/UC36	1.00	1.01	1.00
-	HC30	1.00	1.03	1.00
-	HC36	1.01	1.04	1.01
-	HD36	1.01	1.05	1.01

* = Single-phase outdoor units only.

Variable Speed Furnace *	Coil	T.C.	S.C.	KW
PV8*A12	FC/MC/PC30A	1.01	1.00	1.01
PV9*A12	FC/MC/PC30A	1.01	1.02	0.97
PV8*B16	FC/MC/PC30B	1.01	1.00	1.01
P(C,V)9*B12	FC/MC/PC30B	1.01	1.00	1.01
PV8*A12	FC/MC/PC36A	1.01	1.02	1.01
PV9*A12	FC/MC/PC36A	1.01	1.03	0.97
PV8*B16	FC/MC/PC36B	1.01	1.03	0.97
P(C,V)9*B12	FC/MC/PC36B	1.01	1.03	0.97
PV8*C16	FC/MC/PC36C	1.01	1.02	1.01
PV8*C20	FC/MC/PC36C	1.01	1.02	1.01
P(C,V)9*C16	FC/MC/PC36C	1.01	1.02	0.97
P(C,V)9*C20	FC/MC/PC36C	1.01	1.02	0.97
PV8*A12	HC30	1.01	1.03	0.97
PV9*A12	HC30	1.01	1.03	0.97
PV8*B16	HC36	1.01	1.05	0.97
P(C,V)9*B12	HC36	1.01	1.05	0.97
PV8*A12	HD36	1.01	1.05	0.97
PV8*B16	HD36	1.01	1.06	0.97
PV8*C16	HD36	1.01	1.06	0.97
PV8*C20	HD36	1.01	1.06	0.97
PV9*A12	HD36	1.01	1.05	0.97
P(C,V)9*B12	HD36	1.01	1.06	0.97
P(C,V)9*C16	HD36	1.01	1.06	0.97
P(C,V)9*C20	HD36	1.01	1.06	0.97

* = Single-phase outdoor units only.

COOLING PERFORMANCE DATA																
AIR CONDITIONER MODEL NO.		H2RD036S06 , H1RD036S(25,46) **														
INDOOR COIL MODEL NO.		FC/MC/PC/UC36														
CONDENSING ENTERING AIR TEMPERATURE	IDCFM	1000					1200					1400				
	ID DB (°F)	80	80	75	80	80	80	80	75	80	80	80	80	75	80	80
	ID WB (°F)	57	62	62	67	72	57	62	62	67	72	57	62	62	67	72
65	T.C.	35.0	35.7	34.7	38.9	40.5	37.2	37.2	35.8	40.0	41.4	39.3	38.8	36.9	41.1	42.3
	S.C.	32.1	30.0	25.0	25.8	19.7	33.8	32.8	27.5	28.1	21.3	35.6	35.7	29.9	30.4	22.9
	KW	2.0	2.0	2.0	2.0	2.1	2.0	2.0	2.0	2.0	2.1	2.0	2.0	2.0	2.0	2.1
75	T.C.	33.3	34.2	33.1	37.0	38.7	35.6	35.9	34.3	38.1	39.5	38.0	37.6	35.4	39.1	40.4
	S.C.	30.5	29.0	24.3	24.9	19.2	32.3	31.7	26.7	27.2	20.7	34.2	34.4	29.1	29.5	22.3
	KW	2.2	2.2	2.2	2.2	2.3	2.2	2.2	2.2	2.2	2.3	2.2	2.2	2.2	2.2	2.3
85	T.C.	31.6	32.6	31.6	35.1	36.8	34.1	34.5	32.8	36.1	37.7	36.6	36.3	34.0	37.1	38.5
	S.C.	28.8	28.0	23.5	24.0	18.6	30.8	30.6	25.9	26.4	20.2	32.9	33.2	28.4	28.7	21.8
	KW	2.3	2.4	2.4	2.4	2.5	2.4	2.4	2.4	2.4	2.5	2.4	2.4	2.4	2.4	2.5
95	T.C.	29.9	31.1	30.0	33.2	35.0	32.5	33.1	31.3	34.8	35.8	35.2	35.1	32.5	35.1	36.6
	S.C.	27.2	27.0	22.7	23.1	18.0	29.3	29.5	25.2	25.4	19.6	31.5	31.9	27.6	27.9	21.2
	KW	2.5	2.5	2.5	2.6	2.7	2.5	2.6	2.6	2.6	2.7	2.6	2.6	2.6	2.6	2.7
105	T.C.	28.8	29.5	28.1	31.1	32.6	31.0	31.3	29.2	32.0	33.3	33.3	33.2	30.3	33.0	34.0
	S.C.	26.1	25.9	21.7	22.2	17.3	27.9	28.0	24.0	24.5	18.8	29.7	30.1	26.3	26.9	20.4
	KW	2.7	2.7	2.7	2.8	2.9	2.7	2.8	2.7	2.8	2.9	2.8	2.8	2.8	2.8	2.9
115	T.C.	27.7	27.9	26.3	29.1	30.4	29.6	29.6	27.2	30.0	30.9	31.5	31.3	28.2	30.9	31.4
	S.C.	25.0	24.9	20.7	21.3	16.6	26.5	26.6	22.9	23.6	18.1	28.0	28.4	25.0	25.9	19.6
	KW	2.9	2.9	2.9	3.0	3.1	2.9	2.9	2.9	3.0	3.1	3.0	3.0	2.9	3.0	3.1
125	T.C.	26.6	26.3	24.4	27.0	28.1	28.2	27.9	25.3	27.9	28.4	29.7	29.5	26.1	28.8	28.8
	S.C.	24.0	23.8	19.8	20.4	15.9	25.1	25.3	21.7	22.7	17.3	26.2	26.7	23.7	25.0	18.8
	KW	3.1	3.1	3.0	3.1	3.3	3.1	3.1	3.1	3.2	3.3	3.2	3.2	3.1	3.2	3.3

NOTE: ALL CAPACITIES INCLUDE INDOOR FAN HEAT AT 1250 BTUH/1000 CFM.
 ** For three-phase, decrease T.C. by 0.3 and S.C. by 0.2.

Multipliers for determining the performance with other indoor sections.

NOTE: For dry bulb temperatures different than those listed (between 73-87 F), sensible capacity increases by 1060 BTUH per 1000 CFM per degree above the listed temperature and decreases by 1060 BTUH per 1000 CFM per degree below the listed temperature.

Air Handler	Coil	T.C.	S.C.	KW
MA12B	FC/MC36B	1.00	1.00	1.00
AHP36	—	1.01	1.07	1.01
AHP42	—	1.01	1.08	1.01
AHP/SHP60	—	1.03	1.05	0.99
F*FP040	—	1.00	1.00	1.00
MV12B*	FC/MC36B	1.01	0.98	1.01
MV16C*	FC/MC36C	1.01	0.99	0.97
AV36*	—	1.01	0.99	0.97
AV/SV48*	—	1.03	0.99	1.00
—	HC36	1.01	1.01	1.01
—	HD36	1.03	1.05	1.03

* = Single-phase outdoor units only.

Variable Speed Furnace *	Coil	T.C.	S.C.	KW
PV8*A12	FC/MC/PC36A	1.01	1.00	1.01
PV9*A12	FC/MC/PC36A	1.00	1.00	1.00
PV8*B16	FC/MC/PC36B	1.01	1.01	1.01
P(C,V)9*B12	FC/MC/PC36B	1.01	1.00	1.01
PV8*C16	FC/MC/PC36C	1.01	1.01	0.97
PV8*C20	FC/MC/PC36C	1.01	1.01	0.97
P(C,V)9*C16	FC/MC/PC36C	1.01	1.01	1.01
P(C,V)9*C20	FC/MC/PC36C	1.01	1.01	0.97
PV8*B16	HC36	1.03	1.05	0.99
P(C,V)9*B12	HC36	1.03	1.04	1.03
PV8*A12	HD36	1.03	1.05	1.03
PV8*B16	HD36	1.03	1.06	0.99
PV8*C16	HD36	1.03	1.06	0.99
PV8*C20	HD36	1.03	1.06	0.99
PV9*A12	HD36	1.03	1.05	1.03
P(C,V)9*B12	HD36	1.03	1.05	0.99
P(C,V)9*C16	HD36	1.03	1.06	0.99
P(C,V)9*C20	HD36	1.03	1.06	0.99

* = Single-phase outdoor units only.

COOLING PERFORMANCE DATA																
AIR CONDITIONER MODEL NO.		H2RD042S06 , H1RD042S(25,46) **														
INDOOR COIL MODEL NO.		FC/MC/PC/UC42														
CONDENSING ENTERING AIR TEMPERATURE	IDCFM	1200					1400					1600				
	ID DB (°F)	80	80	75	80	80	80	80	75	80	80	80	80	75	80	80
	ID WB (°F)	57	62	62	67	72	57	62	62	67	72	57	62	62	67	72
65	T.C.	39.6	44.0	42.6	46.7	50.0	41.5	45.0	43.4	47.6	50.4	43.4	46.0	44.3	48.5	50.8
	S.C.	39.3	37.3	30.7	31.1	23.6	41.0	39.7	33.1	33.3	24.7	42.7	42.2	35.5	35.5	25.7
	KW	2.3	2.3	2.3	2.3	2.3	2.3	2.3	2.3	2.3	2.3	2.3	2.3	2.3	2.3	2.3
75	T.C.	38.0	41.8	40.3	44.4	47.2	40.0	42.9	41.1	45.2	47.7	41.9	43.9	41.9	46.0	48.1
	S.C.	37.6	36.1	29.8	30.0	22.7	39.3	38.5	32.0	32.2	23.8	40.9	40.8	34.2	34.4	24.8
	KW	2.5	2.5	2.5	2.5	2.6	2.5	2.5	2.5	2.5	2.6	2.5	2.5	2.5	2.5	2.6
85	T.C.	36.4	39.6	38.0	42.1	44.4	38.4	40.7	38.7	42.8	44.9	40.4	41.9	39.4	43.4	45.4
	S.C.	36.0	34.9	28.8	28.9	21.8	37.6	37.2	30.9	31.1	22.9	39.2	39.5	33.0	33.4	24.0
	KW	2.7	2.7	2.7	2.7	2.8	2.7	2.7	2.7	2.7	2.8	2.7	2.7	2.7	2.8	2.8
95	T.C.	34.7	37.4	35.7	39.8	41.6	36.9	38.6	36.3	40.5	42.2	39.0	39.8	36.9	40.9	42.8
	S.C.	34.3	33.8	27.8	27.8	20.8	35.9	36.0	29.8	29.6	22.0	37.4	38.2	31.7	32.3	23.1
	KW	2.9	2.9	2.9	3.0	3.1	2.9	2.9	2.9	3.0	3.1	2.9	2.9	2.9	3.0	3.1
105	T.C.	33.3	35.6	33.5	37.4	39.0	35.2	36.7	34.1	37.9	39.4	37.2	37.7	34.7	38.4	39.8
	S.C.	32.1	32.6	26.9	26.9	19.8	33.8	34.5	28.8	29.0	21.0	35.6	36.3	30.8	31.2	22.2
	KW	3.1	3.1	3.1	3.2	3.3	3.1	3.1	3.1	3.2	3.3	3.2	3.2	3.1	3.2	3.3
115	T.C.	31.9	33.8	31.4	35.1	36.4	33.6	34.7	31.9	35.6	36.6	35.4	35.7	32.5	36.0	36.8
	S.C.	31.4	31.5	26.0	26.0	18.9	32.6	33.0	27.9	28.0	20.1	33.8	34.5	29.8	30.1	21.3
	KW	3.3	3.3	3.3	3.4	3.5	3.4	3.4	3.3	3.4	3.5	3.4	3.4	3.4	3.4	3.6
125	T.C.	30.5	32.0	29.2	32.8	33.9	32.1	32.8	29.8	33.2	33.9	33.6	33.7	30.3	33.6	33.9
	S.C.	30.0	30.4	25.2	25.1	17.9	31.0	31.5	27.0	27.0	19.1	32.1	32.6	28.8	28.9	20.4
	KW	3.5	3.5	3.5	3.6	3.8	3.6	3.6	3.5	3.6	3.8	3.6	3.6	3.6	3.7	3.8

NOTE: ALL CAPACITIES INCLUDE INDOOR FAN HEAT AT 1250 BTUH/1000 CFM.
 ** For three-phase, decrease T.C. by 1.0 and S.C. by 0.7.

Multipliers for determining the performance with other indoor sections.

NOTE: For dry bulb temperatures different than those listed (between 73-87 F), sensible capacity increases by 1060 BTUH per 1000 CFM per degree above the listed temperature and decreases by 1060 BTUH per 1000 CFM per degree below the listed temperature.

Air Handler	Coil	T.C.	S.C.	KW
MA12C	MC42C	1.00	1.00	1.00
MA14D	MC42D	1.00	1.00	1.00
MA12C	MC48C	1.01	1.02	1.01
MA14D	MC48D	1.01	1.02	1.01
AHP42	-	1.01	1.05	1.01
AHP/SHP48	-	1.04	1.04	1.04
AHP/SHP60	-	1.00	1.12	0.96
MV16C*	FC/MC42C	1.00	0.98	1.00
MV16C*	FC/MC48C	1.02	1.00	0.98
MV20D*	FC/MC48D	1.02	1.01	0.98
AV/SV48*	-	1.00	0.98	1.00
-	FC/MC/PC/UC48	1.01	1.02	1.01
-	HC42	1.01	1.01	1.01
-	HD48	1.02	1.00	1.02

* = Single-phase outdoor units only.

Variable Speed Furnace *	Coil	T.C.	S.C.	KW
PV8*B16	FC/MC/PC42B	1.00	1.00	1.00
PV8*C16	FC/MC/PC42C	1.00	1.00	1.00
PV8*C20	FC/MC/PC42C	1.00	1.00	1.00
PV8*C16	FC/MC/PC48C	1.02	1.02	1.02
PV8*C20	FC/MC/PC48C	1.02	1.02	0.98
P(C,V)9*C16	FC/MC/PC48C	1.02	1.02	1.02
P(C,V)9*C20	FC/MC/PC48C	1.02	1.02	1.02
P(C,V)9*D20	FC/MC/PC48D	1.02	1.02	1.02
PV8*C16	HC42	1.01	1.01	1.01
PV8*C20	HC42	1.02	1.02	1.02
P(C,V)9*C16	HC42	1.01	1.01	1.01
P(C,V)9*C20	HC42	1.01	1.02	1.01
PV8*C16	HD48	1.04	1.03	0.99
PV8*C20	HD48	1.04	1.03	0.99
P(C,V)9*C16	HD48	1.04	1.03	1.04
P(C,V)9*C20	HD48	1.04	1.03	0.99
P(C,V)9*D20	HD48	1.04	1.03	0.99

* = Single-phase outdoor units only.

COOLING PERFORMANCE DATA																
AIR CONDITIONER MODEL NO.		H2RD048S06, H1RD048S(25,46) **														
INDOOR COIL MODEL NO.		FC/MC/PC/UC48														
CONDENSING ENTERING AIR TEMPERATURE	IDCFM	1400					1600					1800				
	ID DB (°F)	80	80	75	80	80	80	80	75	80	80	80	80	75	80	80
	ID WB (°F)	57	62	62	67	72	57	62	62	67	72	57	62	62	67	72
65	T.C.	45.9	49.0	47.2	51.9	54.5	48.7	50.8	48.2	52.9	54.7	51.5	52.5	49.2	53.9	54.9
	S.C.	44.2	41.8	34.6	34.7	27.5	45.8	44.4	36.9	36.9	28.2	47.5	47.0	39.2	39.0	29.0
	KW	2.6	2.6	2.6	2.7	2.7	2.6	2.6	2.6	2.7	2.7	2.6	2.6	2.6	2.7	2.7
75	T.C.	44.6	47.5	45.7	50.3	52.8	47.4	48.9	46.5	51.0	53.0	50.1	50.4	47.4	51.7	53.2
	S.C.	42.9	41.2	34.0	34.2	26.9	44.5	43.7	36.2	36.3	28.0	46.1	46.1	38.5	38.4	29.0
	KW	3.0	3.0	3.0	3.0	3.0	3.0	3.0	3.0	3.0	3.0	3.0	3.0	3.0	3.0	3.0
85	T.C.	43.3	45.9	44.1	48.7	51.1	46.0	47.1	44.9	49.1	51.3	48.8	48.2	45.6	49.6	51.6
	S.C.	41.6	40.6	33.4	33.7	26.4	43.1	42.9	35.6	35.7	27.7	44.6	45.2	37.7	37.8	28.9
	KW	3.3	3.3	3.3	3.4	3.4	3.3	3.3	3.3	3.4	3.4	3.3	3.3	3.3	3.4	3.4
95	T.C.	42.0	44.4	42.6	47.1	49.3	44.7	45.2	43.2	47.0	49.7	47.4	46.1	43.8	47.5	50.0
	S.C.	40.4	39.9	32.8	33.1	25.9	41.8	42.1	34.9	35.1	27.4	43.1	44.3	37.0	37.2	28.9
	KW	3.7	3.7	3.6	3.7	3.7	3.7	3.7	3.7	3.7	3.7	3.7	3.7	3.7	3.7	3.7
105	T.C.	40.5	42.5	40.5	44.7	46.4	43.1	43.5	41.1	44.8	46.7	45.6	44.4	41.7	45.0	47.0
	S.C.	38.7	38.5	31.8	32.2	24.9	40.0	40.4	33.9	34.2	26.4	41.4	42.3	36.0	36.3	27.8
	KW	4.2	4.2	4.1	4.2	4.2	4.2	4.2	4.2	4.2	4.2	4.2	4.2	4.2	4.2	4.2
115	T.C.	39.1	40.7	38.4	42.3	43.5	41.5	41.7	39.0	42.5	43.8	43.9	42.8	39.7	42.6	44.1
	S.C.	37.2	37.2	30.8	31.2	24.0	38.4	38.7	32.9	33.3	25.4	39.6	40.3	35.0	35.4	26.8
	KW	4.7	4.6	4.6	4.7	4.7	4.7	4.7	4.6	4.7	4.7	4.7	4.7	4.6	4.7	4.7
125	T.C.	37.7	38.8	36.3	40.0	40.7	39.9	40.0	37.0	40.1	40.9	42.1	41.2	37.6	40.3	41.2
	S.C.	35.6	35.8	29.9	30.3	23.1	36.7	37.0	32.0	32.4	24.4	37.9	38.3	34.0	34.5	25.8
	KW	5.2	5.1	5.1	5.2	5.2	5.2	5.1	5.1	5.2	5.2	5.2	5.2	5.1	5.2	5.2

NOTE: ALL CAPACITIES INCLUDE INDOOR FAN HEAT AT 1250 BTUH/1000 CFM.
 ** For three-phase, decrease T.C. by 1.0 and S.C. by 0.7.

Multipliers for determining the performance with other indoor sections.

NOTE: For dry bulb temperatures different than those listed (between 73-87 F), sensible capacity increases by 1060 BTUH per 1000 CFM per degree above the listed temperature and decreases by 1060 BTUH per 1000 CFM per degree below the listed temperature.

Air Handler	Coil	T.C.	S.C.	KW
MA12C	MC48C	1.01	1.02	1.01
MA20D	MC48D	1.00	1.00	1.00
AHP/SHP48	-	1.00	1.05	1.00
F*FV060*	-	1.01	1.05	1.01
AHP/SHP60	-	1.01	1.03	1.01
MV16C*	FC/MC48C	1.00	0.99	1.00
MV20D*	FC/MC48D	1.00	0.99	1.00
AV/SV48*	-	1.00	0.99	1.00
-	HD48	1.00	0.99	1.00

* = Single-phase outdoor units only.

Variable Speed Furnace *	Coil	T.C.	S.C.	KW
PV8*C16	FC/MC/PC48C	0.99	0.97	0.99
PV8*C20	FC/MC/PC48C	1.00	1.00	1.00
P(C,V)9*C16	FC/MC/PC48C	1.00	1.00	1.00
P(C,V)9*C20	FC/MC/PC48C	1.00	1.00	1.00
P(C,V)9*D20	FC/MC/PC48D	1.00	1.00	1.00
PV8*C16	HD48	1.01	0.99	1.01
PV8*C20	HD48	1.01	1.02	1.01
P(C,V)9*C16	HD48	1.01	1.02	1.01
P(C,V)9*C20	HD48	1.01	1.02	1.01
P(C,V)9*D20	HD48	1.01	1.02	1.01

* = Single-phase outdoor units only.

COOLING PERFORMANCE DATA

AIR CONDITIONER MODEL NO.		H2RD060S06, H1RD060S(25,46)**														
INDOOR COIL MODEL NO.		FC/MC/PC/UC60														
CONDENSING ENTERING AIR TEMPERATURE	IDCFM	1650					1900					2150				
	ID DB (°F)	80	80	75	80	80	80	80	75	80	80	80	80	75	80	80
	ID WB (°F)	57	62	62	67	72	57	62	62	67	72	57	62	62	67	72
65	T.C.	57.2	57.4	54.0	59.6	59.1	58.9	59.1	55.2	60.4	61.1	60.6	60.8	56.3	61.2	63.1
	S.C.	52.1	48.7	39.6	38.8	28.1	54.1	51.9	42.7	42.0	31.1	56.1	55.2	45.7	45.3	34.1
	KW	3.0	3.1	3.1	3.1	3.1	3.0	3.1	3.1	3.1	3.1	3.1	3.1	3.1	3.1	3.1
75	T.C.	54.9	55.1	51.6	57.2	57.0	56.9	56.8	52.7	58.1	58.2	59.0	58.5	53.8	59.0	59.5
	S.C.	50.0	47.4	38.6	38.0	27.7	52.1	50.5	41.6	41.1	30.0	54.2	53.6	44.7	44.2	32.3
	KW	3.5	3.5	3.5	3.6	3.6	3.5	3.5	3.5	3.6	3.6	3.5	3.5	3.5	3.6	3.6
85	T.C.	52.6	52.9	49.3	54.8	54.8	54.9	54.5	50.3	55.8	55.4	57.3	56.1	51.2	56.9	55.9
	S.C.	48.0	46.1	37.6	37.3	27.3	50.1	49.0	40.6	40.2	28.8	52.3	52.0	43.6	43.2	30.4
	KW	4.0	4.0	4.0	4.0	4.1	4.0	4.0	4.0	4.0	4.1	4.0	4.0	4.0	4.0	4.1
95	T.C.	50.2	50.7	46.9	52.4	52.7	52.9	52.2	47.8	55.0	52.5	55.6	53.7	48.7	54.7	52.3
	S.C.	45.9	44.8	36.5	36.5	26.9	48.1	47.6	39.5	39.6	27.7	50.4	50.4	42.5	42.1	28.5
	KW	4.4	4.4	4.4	4.4	4.6	4.5	4.4	4.4	4.5	4.6	4.5	4.4	4.4	4.5	4.6
105	T.C.	48.3	48.2	44.9	49.9	49.4	50.5	49.9	45.3	50.8	49.2	52.8	51.6	45.6	51.6	49.0
	S.C.	43.9	43.2	35.6	35.4	25.7	46.0	45.6	38.4	38.1	26.8	48.0	47.9	41.1	40.8	28.0
	KW	5.1	5.0	5.1	5.1	5.2	5.1	5.1	5.1	5.1	5.2	5.1	5.1	5.1	5.1	5.2
115	T.C.	46.4	45.9	43.0	47.5	46.1	48.2	47.7	42.8	48.1	46.0	50.0	49.6	42.5	48.6	45.9
	S.C.	42.0	41.7	34.7	34.4	24.6	43.9	43.6	37.2	37.0	26.0	45.7	45.5	39.8	39.5	27.5
	KW	5.7	5.7	5.7	5.7	5.8	5.7	5.7	5.7	5.7	5.8	5.7	5.7	5.7	5.7	5.8
125	T.C.	44.5	43.5	41.1	45.1	42.9	45.8	45.5	40.3	45.3	42.8	47.2	47.6	39.5	45.6	42.7
	S.C.	40.1	40.2	33.7	33.4	23.5	41.8	41.6	36.1	35.8	25.2	43.4	43.1	38.4	38.3	26.9
	KW	6.3	6.3	6.3	6.3	6.4	6.3	6.3	6.3	6.3	6.5	6.3	6.4	6.3	6.3	6.5

NOTE: ALL CAPACITIES INCLUDE INDOOR FAN HEAT AT 1250 BTUH/1000 CFM.
****** For three-phase, decrease T.C. by 0.5 and S.C. by 0.3.

Multipliers for determining the performance with other indoor sections.

NOTE: For dry bulb temperatures different than those listed (between 73-87 F), sensible capacity increases by 1060 BTUH per 1000 CFM per degree above the listed temperature and decreases by 1060 BTUH per 1000 CFM per degree below the listed temperature.

Air Handler	Coil	T.C.	S.C.	KW
MA20D	MC60D	1.00	1.00	1.00
MA20D	MC61D	1.01	1.01	1.01
AHP/SHP60	-	1.00	1.02	1.00
F*FV060*	-	1.00	1.02	1.00
MV20D*	FC/MC60D	0.98	0.97	0.98
MV20D*	MC61D	1.01	0.99	1.01
AV/SV60*	-	1.00	1.02	1.00
-	MC61	1.01	1.01	1.01
-	HC60	1.00	1.00	1.00
-	HD60	1.00	1.01	1.00
MA20D	MC60D	1.00	1.00	1.00

* = Single-phase outdoor units only.

Variable Speed Furnace*	Coil	T.C.	S.C.	KW
P(C,V)9*D20	FC/MC/PC60D	0.99	0.96	0.99
PV8*C20	FC/PC60C	0.98	0.98	0.98
P(C,V)9*C20	FC/PC60C	0.99	0.96	0.99
PV8*C20	HC60	0.98	0.98	0.98
P(C,V)9*D20	HC60	0.99	0.96	0.99
PV8*C20	HD60	1.00	0.99	1.00
P(C,V)9*C20	HD60	0.99	0.96	0.99
P(C,V)9*D20	HD60	0.98	0.96	0.98
PV8*C20	MC61D	1.00	0.99	1.00
P(C,V)9*C20	MC61D	0.98	0.96	0.98
P(C,V)9*D20	MC61D	1.00	0.96	1.00

* = Single-phase outdoor units only.

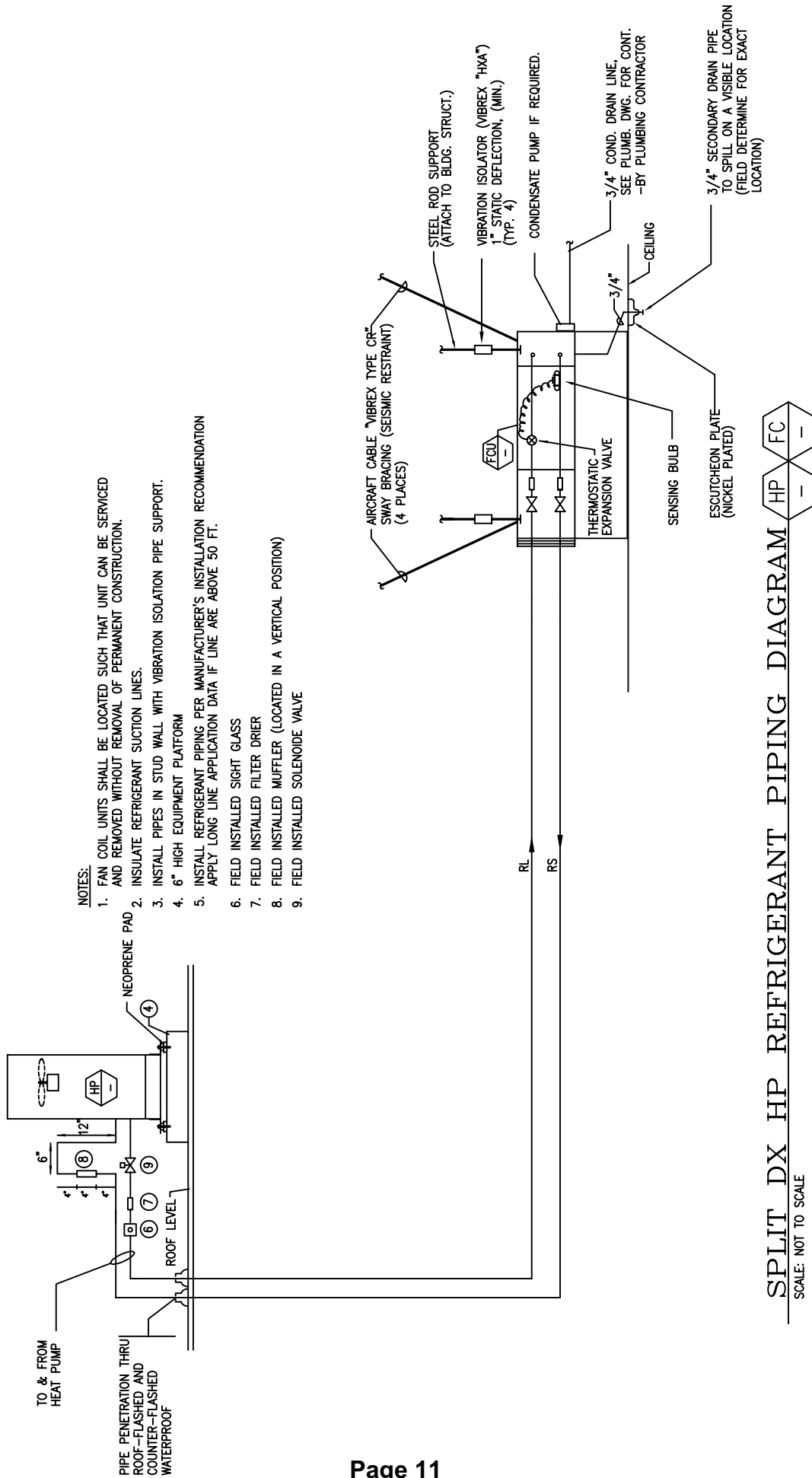

NOTES:

1. FAN COIL UNITS SHALL BE LOCATED SUCH THAT UNIT CAN BE SERVICED AND REMOVED WITHOUT REMOVAL OF PERMANENT CONSTRUCTION.
2. INSULATE REFRIGERANT SUCTION LINES.
3. INSTALL PIPES IN STUD WALL WITH VIBRATION ISOLATION PIPE SUPPORT.
4. 6" HIGH EQUIPMENT PLATFORM
5. INSTALL REFRIGERANT PIPING PER MANUFACTURER'S INSTALLATION RECOMMENDATION APPLY LONG LINE APPLICATION DATA IF LINE ARE ABOVE 50 FT.
6. FIELD INSTALLED SIGHT GLASS
7. FIELD INSTALLED FILTER DRIER
8. FIELD INSTALLED MUFFLER (LOCATED IN A VERTICAL POSITION)
9. FIELD INSTALLED SOLENOIDE VALVE

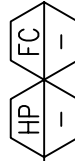

SPLIT DX HP REFRIGERANT PIPING DIAGRAM

SCALE: NOT TO SCALE

R-410a Refrigerant lines and the losses												
Unit Nominal Size	Liquid Line is 3/8" Vapor Line Diameters (In. O.D.)	Cooling Capacity Loss (%) Total Equivalent Line Length (ft)										
		25'	50'	80'	100'	125'	150'	175'	200'	225'	250'	
1.5 Ton	1/2	1	2	3	4	6	7	8	9	10	12	
	5/8	0	0	1	1	1	2	2	3	3	3	
	5/8	0	1	1	2	3	3	4	4	5	6	
2 Tons	3/4	0	0	0	0	1	1	1	1	1	2	
	7/8	0	0	0	0	0	0	0	0	0	1	
	5/8	1	2	3	3	4	5	6	7	8	9	
2.5 Tons	3/4	0	0	1	1	1	2	2	2	3	3	
	7/8	0	0	0	0	1	1	1	1	1	1	
	5/8	1	2	4	5	6	7	9	10	11	13	
3 tons	3/4	0	0	1	1	2	2	3	3	4	4	
	7/8	0	0	0	0	1	1	1	1	2	2	
	3/4	0	1	2	2	3	4	4	5	6	6	
3.5 Tons	7/8	0	0	1	1	1	2	2	2	3	3	
	1--1/8	0	0	0	0	0	0	0	0	0	1	
	3/4	0	1	2	3	4	5	5	6	7	8	
4 Tons	7/8	0	0	1	1	2	2	2	3	3	4	
	1--1/8	0	0	0	0	0	0	0	1	1	1	
	3/4	1	2	4	5	6	7	9	10	11	12	
5 Tons	7/8	0	1	2	2	3	4	4	5	5	6	
	1--1/8	0	0	0	1	1	1	1	1	1	2	

Required Accessories are Solenoid valve, crankcase heater, star capacitor, hard shut off TXV, filter drier.

VENSTAR®

COMMERCIAL THERMOSTAT

MODEL NO. T2950

365-DAY PROGRAMMABLE

UP TO 3-HEAT
& 2-COOL

HEAT
COOL & HEAT
PUMP

TITLE-24 COMPLIANT

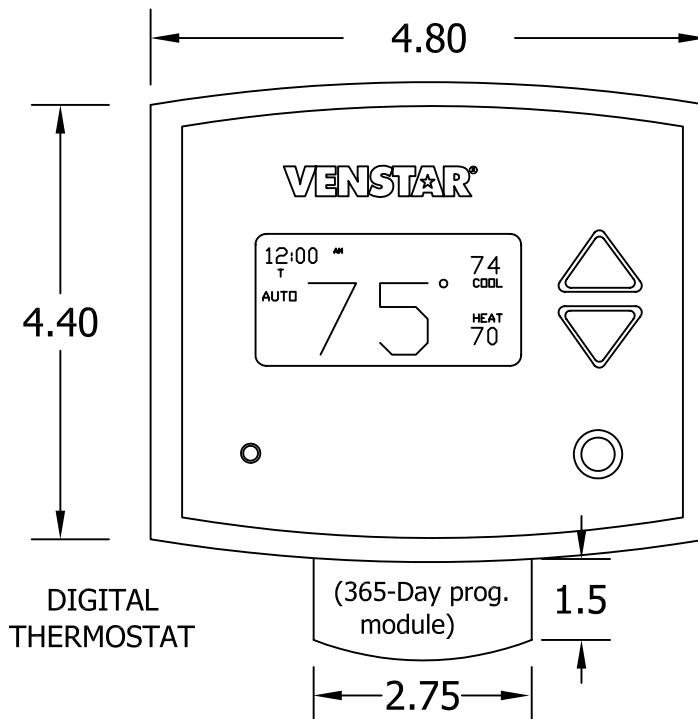

STANDARD FEATURES:

- **365-day programmable (up to 10 years, includes full calendar with preprogrammed holidays)**
- Up to 3-Occupied, 1-Unoccupied periods per day, with copy command for easy programming
- **Light Activated occupied period (defeatable)**
- **Auto changeover, 3-stage heat, 2-stage cool for use with gas/electric, heat pump, split systems, electric & hydronic heat**
- Configurable for manual changeover, also configurable programmable or non-programmable
- Adjustable deadbands and timers
- 2 configurable outputs for maximum flexibility. Can be used for humidification, dehumidification, 3rd stage heating or programmable output for lighting, exhaust fans, remote sensor etc.
- Energy Watch keeps track of energy use by tracking heating and cooling hours
- Smart Fan (keeps the fan from running during unoccupied periods)
- Smart recovery (reaches selected comfort temperature at exact time is scheduled for energy savings)
- **Pre-occupancy fan purge**
- Display shows both heating and cooling setpoints and room temperature simultaneously
- All programming and setpoints stored in non-volatile memory, and are never lost in power failure
- Service filter and service UV lamp indicators
- Red/Green LED shows whether thermostat is calling for heating or cooling
- **5-minute compressor time guard and adjustable cycle limit, both defeatable for servicing equipment**
- Thermoglow backlit electro-luminous display and backlit color coded keys and legends

ACCESORY FEATURES:

- **Accepts humidification/dehumidification control module (Venstar part number ACC0430)**
- **Control to, or monitor a second remote sensor. Can average up to 8 (wired or wireless) remote sensors (Venstar part number ACC0401)**
- Outdoor sensor ready with high and low temperature of the day (Venstar part number ACC0400)
- Accepts accessory IR remote control system (Venstar part number ACC0431)
- Accepts accessory EZ Programmer- programmed via USB through computer (Venstar part number ACC0)
- **For accessory locking cover use (Venstar part number ACC0620)**

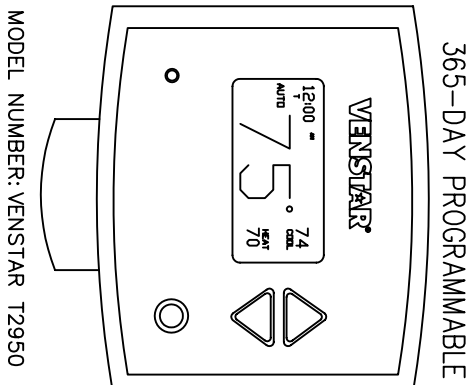

365-DAY PROGRAMMABLE

MODEL NUMBER: VENSTAR T2950

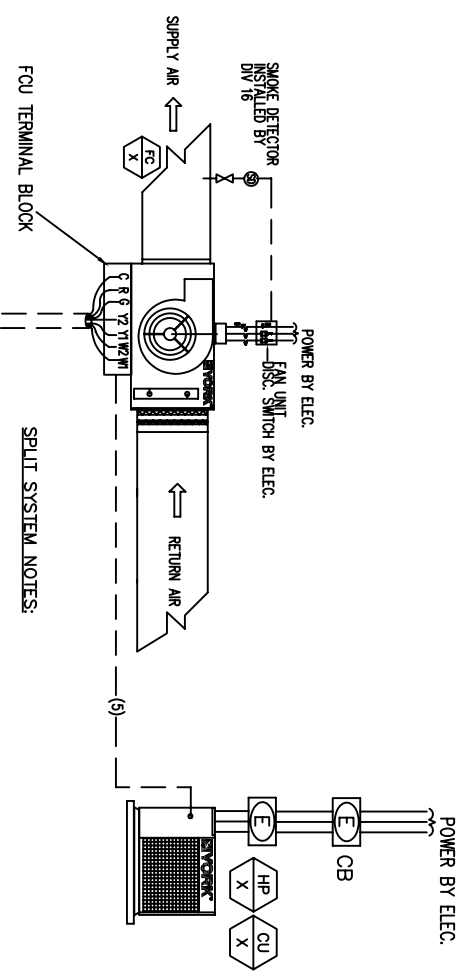

SPLIT SYSTEM NOTES:

1. SEE MANUFACTURER INSTALLATION MANUAL FOR SENSOR INSTALLATION AND REQUIREMENTS.
2. ALL CONTROLS AND EQUIPMENT PROVIDED BY USACD.
3. EACH ROOFTOP UNIT WILL HAVE NECESSARY SAFETIES.
4. THE SYSTEM IS ENABLED AND DISABLED AS PROGRAMMED BY THE PROGRAMMABLE THERMOSTAT (MODEL NO: VENSTAR T2950). TSTAT SHALL BE TITLE-24 APPROVED AND 365-DAY PROGRAMMABLE.

(7) WIRES IN RIGID CONDUIT SEPARATE FROM PWR LINE

WIRING LEGEND:

- 24VAC COMMON — C
- 24VAC POWER — R
- FAN RELAY — G
- 1ST STAGE COOLING — Y1
- 2ND STAGE COOLING — Y2
- 1ST STAGE HEATING — W1
- 2ND STAGE HEATING — W2

TYPICAL STAND ALONE SPLIT SYSTEM CONTROL DIAGRAM

SCALE: NONE

Simplicity[®] Intelli-Comfort[™] Controls

Only York[®] offers the easiest solution to help you take control of controls.

COMFORT
ONLINE ALARMING
NO HASSLE SET-UP
TOTAL HVAC CONTROL SOLUTIONS
RELIABILITY
OPEN PROTOCOL
LOW COST



HVAC control just became a whole lot smarter and easier!

More control for more savings

Cut energy costs, and achieve higher levels of comfort—automatically with Simplicity[®] Intelli-Comfort[™] controls.

More intelligence for more capabilities

Intelli-Comfort controls use intelligent hardware and software to give you better monitoring, more flexibility in control set-up, and finer control of every aspect of your HVAC system. In addition, the more intelligent the control, the greater savings you will realize through operational efficiencies and conservation.

More control for greater comfort

The flexibility of the Simplicity Intelli-Comfort control means comfortable, happier, and more productive occupants—thanks to the ability to optimize temperature, humidity, and indoor air quality simultaneously.

More compatibility for more flexibility

The controls are compatible with the MODBUS protocol, and are factory-installed on 3- to 25-ton Sunline[™] and Predator[®] products and Millennium[®] HA/HB Systems.

More power with less effort

Intelli-Comfort is a control that's so easy to use that you actually benefit from the power at your fingertips.

Easier to manage

Intelli-Comfort raises the intelligence of an already smart Simplicity control.

Put the intelligence of Simplicity Intelli-Comfort controls to work in your building.

Simplicity Intelli-Comfort controls give you powerful capabilities without complexity. Easy to set-up, program, and use, the controls give you everything you need to monitor and control Sunline and Predator units. And because they can be connected as your HVAC Energy Management System you can save even more by making the intelligence of Simplicity Intelli-Comfort part of your building automation strategy.



New features for superior monitoring and control

365-Day Real Time Clock with automatic Daylight Savings Time adjustment

Occupancy Schedule allowing two different occupied schedules per day for each of the seven days of the week

20 Holiday Schedules with a length of up to 99 days, each with flexible start times. You can now choose the time of day your holiday begins saving energy

Energy-Saving Economizer Operation with the flexibility of using dry bulb, outside enthalpy and differential enthalpy. Our economizer enthalpy control has setpoints for outside air temperature, supply air temperature, small space cooling demand, and large space cooling demand

Outside Air CO₂ Sensor to close the economizer if CO₂ is present

Inside Demand Ventilation using one CO₂ sensor or differential demand ventilation using inside and outside CO₂ sensors

IAQ Operation with programmable maximum outside air damper position

Comfort Ventilation Control tempers the ventilation air when heating or cooling is not required, increasing comfort

Patent Pending Temperature Humidity Algorithm offsets the operating setpoint based on high humidity in the space—with programmable limits to control humidity

High and Low Ambient Lockout to lockout cooling below or heating above a programmable setpoint of outside air temperature

Space Temperature Alarm when temperatures are outside of program setpoints. Alarm setpoints are user programmable

Unit Monitors Airflow to detect dirty filters and insufficient airflow

Intelligent Recovery brings the space temperature to the occupied setpoint just before or at the beginning of the first occupied schedule each day. The control will "learn" and apply the minimum runtime required to heat or cool the space to minimize energy use



LEGEND
 COMM York Control Network
 DCY DemandControlledVentilation
 PAT PrimaryAirTemperatureSensor
 RTU Rooftop Unit

(OPTIONAL)
 OWNER PROVIDES FRONT END COMPUTER
 AND WINDOWS OPERATING SYSTEM
 GRAPHICS SHALL BE OWNER MAINTAINED

- SYSTEM NOTES:
1. ALL CONDUIT BY DIV. 16
 2. ALL LOW VOLTAGE WIRING BY CONTROL CONTRACTOR.
 3. ALL 120V TO CONTROL DEVICES SHALL BE BY DIV16.

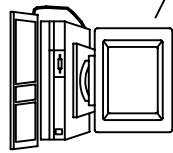

REMOTE PC (VIA INTERNET)

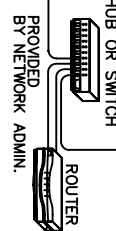

INTERNET CONNECTION
 CUSTOMER FIREWALL

PROVIDED BY NETWORK ADMIN.
 NETWORK BY NETWORK ADMIN.
 TCP/IP

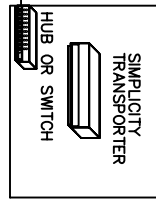

HUB OR SWITCH
 SIMPLICITY TRANSPORTER



73 YORK
 S2 - 031-02529-006 - YORK
 SENSOR WITH SETPOINT ADJUST
 OVERRIDE BUTTON AND LCD
 TYPICAL

COMM BUS IN RIGID CONDUIT
 SEPARATE FROM PWR LINE

RTU TERMINAL BLOCK
 WITH YORK INTELLICOMFORT CONTROLLER

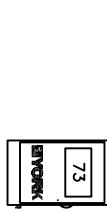

73 YORK

COMM BUS IN RIGID CONDUIT
 SEPARATE FROM PWR LINE

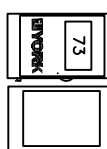

73 YORK

CO2 SENSOR

AC UNIT NOTES:

1. SEE MANUFACTURER INSTALLATION MANUAL FOR SENSOR INSTALLATION AND REQUIREMENTS.
2. ALL CONTROLS AND EQUIPMENT PROVIDED BY USACD.
3. EACH ROOFTOP UNIT WILL HAVE NECESSARY SAFETIES.
4. THE UNIT IS ENABLED AND DISABLED AS PROGRAMMED BY THE PROGRAMMABLE THERMOSTAT (MODEL NO: 031-02529-00). TSTAT SHALL BE TITLE-24 APPROVED AND 7-DAY PROGRAMMABLE.
5. SYSTEM SHALL COMMUNICATE FROM FACTORY STANDARD PROVIDED SIMPLICITY CONTROLLER.
6. UNITS SHALL OPERATE IN STAND ALONE OPERATION.
7. DURING EQUIPMENT ALARM, SYSTEM SHALL RECEIVE ALARM THRU NETWORK TO FRONT END COMPUTER.
8. EQUIPMENT STATUS SHALL BE MONITORED THRU FRONT END. ALL CHANGES SHALL BE DONE AT LOCAL THERMOSTAT.
9. ALARM SHALL ALSO FLASH ON THE CONTROLLER PC BOARD. LED LIGHT SHALL PROVIDE COMPRESSOR LOOKOUT, SUPPLY FAN FAILURE, HEATING/COOLING FAILURE, SAT, PAT, OAT, RH FAILURE SENSOR, DIRTY FILTER ALARM.

TYPICAL SINGLE ZONE CV CONTROL RISER DIAGRAM STANDARD NETWORK

SCALE: NONE

COMMERCIAL ZONING PACKAGE

FACILITY EXPLORER

BY JOHNSON CONTROLS

The Facility Explorer Commercial Zoning Package is a complete, turnkey control system used to improve occupant comfort in a building (or section of a building) that is conditioned with a packaged rooftop HVAC unit. It accomplishes this by varying the amount of conditioned air delivered to individual zones and by intelligently cycling the rooftop unit's heating and cooling stages to best satisfy all the zone demands.

Manufacturer Independent

The Facility Explorer Commercial Zoning Package is designed to work with any standard, packaged HVAC equipment, regardless of manufacturer. This allows you to apply this control package to equipment provided by a variety of suppliers or to equipment that has already been installed. This flexibility makes the Facility Explorer Commercial Zoning Package perfectly suited for both new and retrofit installations.

Affordable Intelligence

The Facility Explorer Commercial Zoning Package utilizes the distributed application architecture of the FX16 Master Controller. This feature allows direct communications to occur between the FX16 and all the zone controllers. This means that there is no need for a traditional supervisory class controller to manage the data sharing. This direct communication flow allows the FX16 to monitor each zone's status to intelligently determine the proper mode of operation for the rooftop unit.



Easy Installation

Several pieces of the Facility Explorer Commercial Zoning Package can be ordered pre-assembled from the factory to simplify installation:

- Zone Controller and Actuator Assembly (FXZAN)
 - The FX05 Field Controller is combined with an M9104AGA non-spring return actuator and an electrical termination wiring block, all in one packaged assembly
 - Perfect for retrofit installations where the zone damper is already installed
- Zone Controller, Actuator, and Damper Assembly
 - FXZAN Zone Controller and Actuator Assembly is combined with a round or rectangular zone damper
 - Perfect for new installations or for retrofit installations where the zone damper has not yet been installed

- Bypass Damper and Actuator Assembly
 - A round or rectangular bypass damper is combined with an M910xHGA non-spring return actuator
- FX16 Master Controller with Pre-Downloaded Zoning Application
 - FX16 Master Controller can be ordered with the commercial zoning application pre-downloaded
 - Once installed, the FX16 takes care of downloading the corresponding parts of the zoning application to each of the zone controllers
 - Eliminates the downloading steps from the field installation and startup
 - This provides the possibility (with an onsite Medium User Interface) to download, configure and commission the entire system, including the rooftop, bypass, and all zone controllers without any software tool

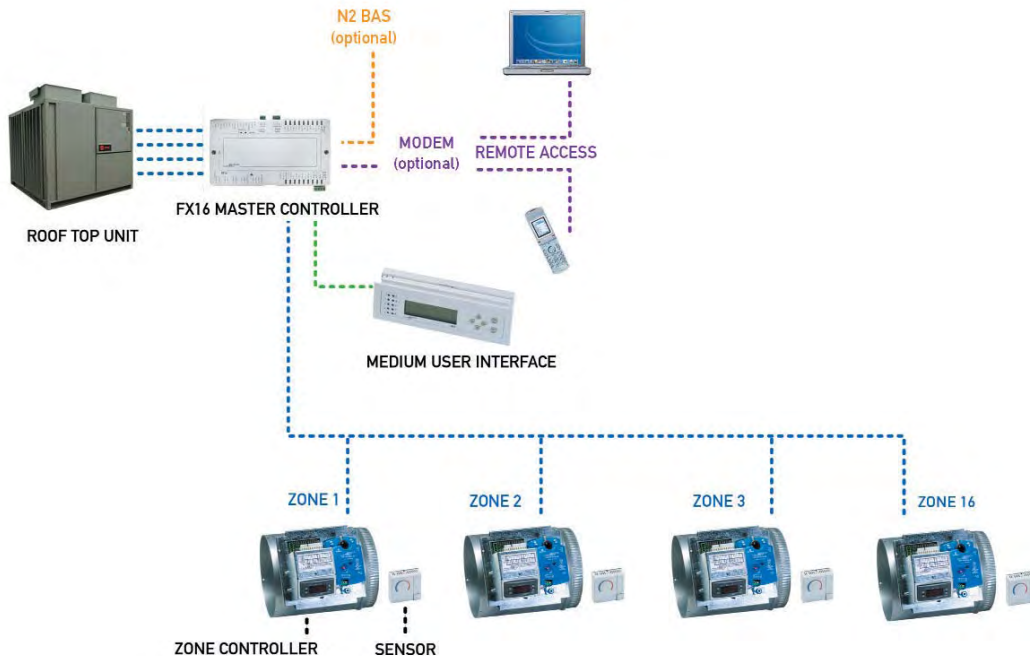

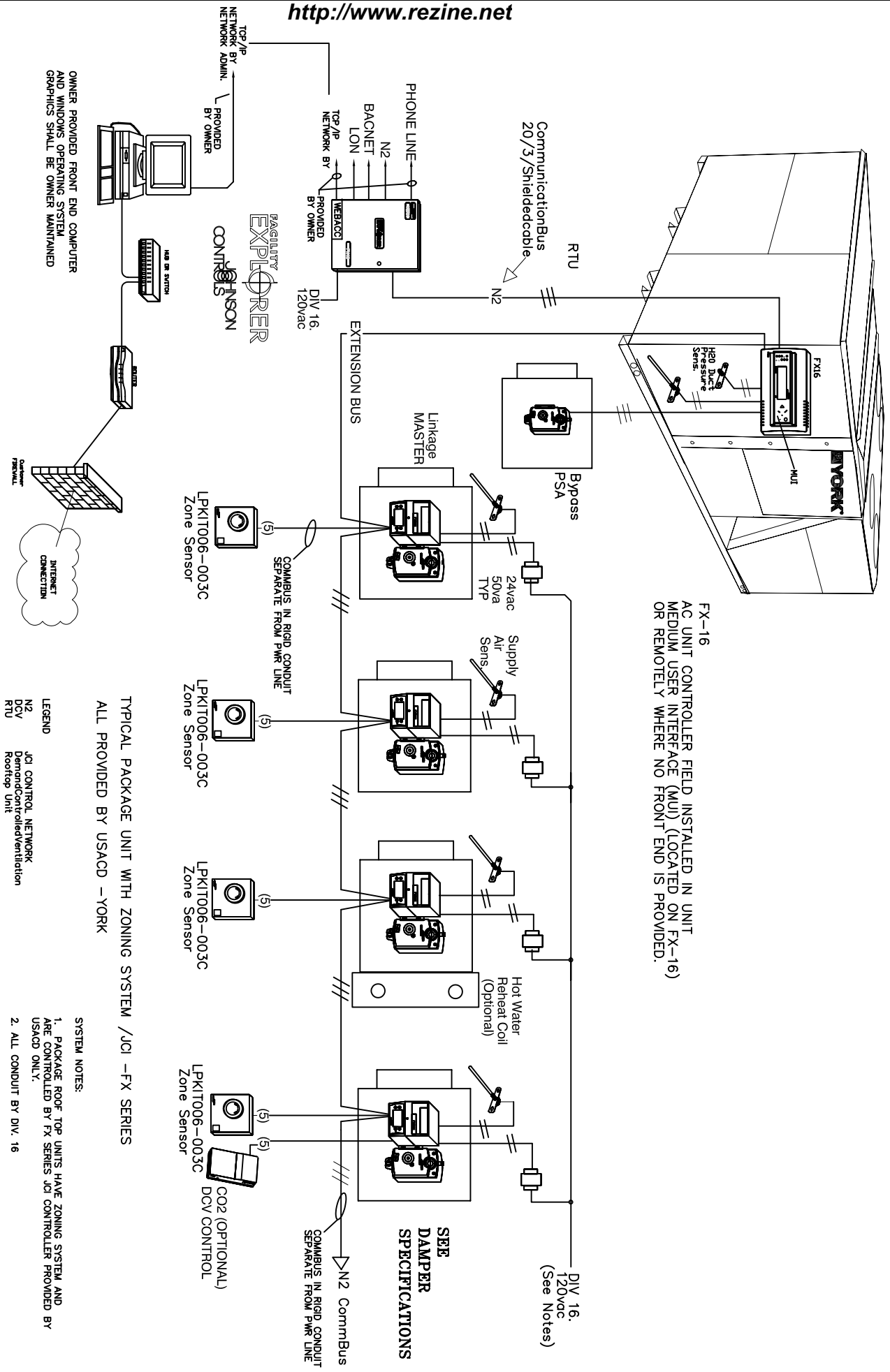

FX-16
AC UNIT CONTROLLER FIELD INSTALLED IN UNIT
MEDIUM USER INTERFACE (MUI) (LOCATED ON FX-16)
OR REMOTELY WHERE NO FRONT END IS PROVIDED.

TYPICAL PACKAGE UNIT WITH ZONING SYSTEM / JCI - FX SERIES
ALL PROVIDED BY USACD - YORK

LEGEND
N2 DCV JCI CONTROL NETWORK
RTU DemandControlledVentilation Rooftop Unit

SYSTEM NOTES:
1. PACKAGE ROOF TOP UNITS HAVE ZONING SYSTEM AND ARE CONTROLLED BY FX SERIES JCI CONTROLLER PROVIDED BY USACD ONLY.
2. ALL CONDUIT BY DIV. 16
3. ALL LOW VOLTAGE WIRING BY CONTROL CONTRACTOR.
4. ALL 120V TO ZONE DAMPERS AND CONTROL DEVICES SHALL BE BY DIV.16
5. ALL SENSORS AND TRANSFORMERS PROVIDED BY CONTROL CONTRACTOR.

TYPICAL ZONING SYSTEM-FX CONTROLS

SCALE: NONE

TSS – Single Duct Variable Air Volume Terminal



- An integrated VAV box with direct digital controls eliminates the coordination and difficulties associated with factory mounting
- Downloading of software, setting of parameters, addressing and testing at the factory reduces startup time and lowers risk
- Superior flow measuring provides for lower minimum cubic feet per minute (CFM) values, which reduces energy costs and noise while maintaining comforts in the zone
- Installation time can be reduced with the low profile compact design and standard metal hanging straps
- Units wired in compliance with all applicable National Electrical Code (NEC) requirements and tested in accordance with Air Conditioning and Refrigeration Institute (ARI) standard 880
- Offers damper stall detection, starved box detection, actuator motor duty cycle, VAV box flow test, and other diagnostics on most models (VMA Series)

TSS Terminals provide Variable Air Volume (VAV) control beyond the typical single duct box. They are specifically designed for precise air delivery throughout the entire operating range, regardless of the installed inlet conditions. These units can be ordered with or without a Direct Digital Controller (DDC), which can operate as a stand-alone unit, on a Johnson Controls N2 trunk, or on a LON® trunk.

TSS Terminals take advantage of typical benefits provided by single duct units, while performing at extremely low sound levels. This is critical in today's buildings where occupants are placing more emphasis on indoor acoustics. The TSS Terminal is manufactured and assembled with a multi-point, center-averaging airflow sensor, which provides a signal to the controller enabling it to quietly and precisely measure airflow.

Bundled with the TSS Terminal is a digital controller from the VAV Modular Assembly (VMA) Series or the LN Series. Each model in the VMA1400 Series and the LN Series combines a controller, pressure sensor, and actuator housed in one pre-assembled unit.

Standard Features

Construction

- ARI 880 certified and labeled
- 22-gauge galvanized steel casing and valve
- G90 galvanized steel
- 1/2", 4lb/ft³ skin, dual density fiberglass insulation, glued and clinch-pinned in place

Hot Water Coils

- ARI 410 certified and labeled
- 1-, 2-, 3-, 4-row coils
- Tested at a minimum of 350 psig under water
- Mechanically expanded copper tubes leak tested to 350 psig air pressure
- Male sweat type water connections

Primary Air Valve

- Embossed rigidity rings
- Low-thermal conducting damper shaft with position indicator
- Mechanical stops for open and closed position
- Multi-point center-averaging airflow sensor
- Brass balancing tees
- Plenum-rated sensor tubing

Electrical Components

- cETL listed for safety compliance
- National Electrical Manufacturers Association (NEMA) Type 1 wiring enclosure

Electric Heat

- ETL listed as an assembly for safety compliance
- Integral electric heat assembly
- Automatic reset primary and back-up secondary thermal limits
- Single-point power connection
- Hinged electrical enclosure
- Fusing per NEC
- Airflow switch
- Ni-chrome elements
- Primary/Secondary power terminations
- Wiring diagram

Optional Features

Construction

- 20-gauge galvanized steel construction
- 3/4" or 1" fiberglass insulation
- Scrim-reinforced, foil-faced insulation meeting American Society for Testing and Materials (ASTM) C1136 for mold, mildew, and humidity resistance
- 1/2" Elastomeric closed-cell foam insulation
- Double wall construction with 22-gauge liner
- Mounting brackets to accept all-thread hanging rods or wire hangers
- Low temperature construction for use in thermal storage applications, including a thermally isolated primary air inlet and a composite damper shaft

Hot Water Coils

- Low pressure steam coils
- Multi-circuit coils for reduced water pressure drop
- Opposite hand water connections
- Bottom and top access plates for cleaning

Electrical Components

- Full unit toggle disconnect and inline motor fusing
- Primary and secondary transformer fusing

Electric Heat

- Proportional solid state relay (SSR) heater control
- Mercury contactors
- Door interlocking disconnect switches
- Disconnect (toggle or door interlocking)
- Pneumatic Electric (PE) switches
- Mercury and magnetic contactors
- Manual reset secondary limit
- 24 volt control transformer
- Special watt densities
- Finned tubular elements

Controls

- Factory-provided controls
- Direct digital controls (DDC) for N2 or LON® networks
- Pneumatic controls

TSL – Single Duct Low Height Variable Air Volume Terminal



- An integrated VAV box with direct digital controls eliminates the coordination and difficulties associated with factory mounting
- Downloading of software, setting of parameters, addressing and testing at the factory reduces startup time and lowers risk
- Superior flow measuring provides for lower minimum cubic feet per minute (CFM) values, which reduces energy costs and noise while maintaining comforts in the zone
- Installation time can be reduced with the low profile compact design and standard metal hanging straps
- Units wired in compliance with all applicable National Electrical Code (NEC) requirements and tested in accordance with Air Conditioning and Refrigeration Institute (ARI) standard 880

TSL Terminals provide variable air volume (VAV) control beyond the typical single duct box. They are specifically designed for precise air delivery throughout the entire operating range and are only 10" in height, making them ideal for shallow or congested ceiling plenum applications. These units can be ordered with or without a Direct Digital Controller (DDC), which can operate as a stand-alone unit, on a Johnson Controls N2 trunk, or on a LON® trunk.

TSL Terminals take advantage of typical benefits provided by single duct units, while performing at extremely low sound levels. This is critical in today's buildings where occupants are placing more emphasis on indoor acoustics. The TSS Terminal is manufactured and assembled with a multi-point, center-averaging airflow sensor, which provides a signal to the controller enabling it to quietly and precisely measure airflow.

Bundled with the TSL Terminal is a digital controller from the VAV Modular Assembly (VMA) Series or the LN Series. Each model in the VMA1400 Series and the LN Series combines a controller, pressure sensor, and actuator housed in one pre-assembled unit.

Standard Features

Construction

- ARI 880 certified and labeled
- 20-gauge, galvanized steel casing and valve
- G90 galvanized steel construction
- 1/2", 4 lb/ft³ skin, dual density fiberglass insulation glued and clinch pinned
- Invertible unit facilitates control installation on the left- or right-hand side

Hot Water Coils

- ARI 410 certified and labeled
- 1-, 2-, 3-, 4-row coils
- Left- or right-hand connections
- Tested at a minimum of 450 psig under water and rated at 300 psig working pressure at 200°F
- Aluminum fin construction with die-formed spacer collars for uniform spacing
- Mechanically expanded copper tubes leak tested to 450 psig air pressure and rated at 300 psig working pressure at 200°F
- Male sweat type water connections

Primary Air Valve

- 18-gauge, G90 galvanized steel construction
- Low thermal conductance damper shaft
- Position indicator on external end of damper shaft
- Mechanical stops for open and closed position
- Multi-point center-averaging airflow sensor
- Brass balancing tees
- Plenum-rated sensor tubing

Electrical Components

- cETL listed for safety compliance with Underwriters Laboratories Inc.® (UL) 1995
- National Electrical Manufacturers Association (NEMA) Type 1 wiring enclosure

Electric Heat

- Invertible unit facilitates control installation on the left- or right-hand side (not applicable if equipped with a mercury contactor)
- cETL listed as an assembly for safety compliance
- Automatic reset primary and back-up secondary thermal limits
- Primary auto-reset high limit

- Secondary high limit
- Airflow switch
- Single-point power connection
- Hinged electrical enclosure door
- Fusing per NEC

Optional Features

Construction

- Scrim-reinforced, foil-faced insulation meeting American Society for Testing and Materials (ASTM) C1136 for mold, mildew, and humidity resistance
- 1/2" Elastomeric closed-cell foam insulation
- Double wall construction with a 22-gauge liner
- Mounting brackets to accept all thread hanging rods or wire hangers
- Discharge sound attenuator (Model TSL-SA)

Hot Water Coil

- Coil access plate for cleaning coil
- Coil circuiting options for reduced water pressure drop
- Right- or left-hand water connections
- Bottom and top access plates for cleaning
- Steam coils

Electrical Components

- Toggle disconnect switch
- Primary and secondary transformer fusing

Electric Heat

- Proportional solid state relay (SSR) heater control
- Mercury contactors (if equipped with a mercury contactor, the unit cannot be inverted)
- Door interlocking disconnect switches
- Disconnect (toggle or door interlocking)
- Pneumatic Electric (PE) switches
- Mercury and magnetic contactors
- Manual reset secondary limit

Controls

- Factory-provided controls
- Direct Digital Controls (DDC), for N2 or LON® networks
- Pneumatic controls

Single Duct Variable Air Volume Terminal (Model TSS)

Unit Size	CFM	Bypass CFM	Weight	Dimensions				
				W x H x L	A	I	X	Y
6	200	300	18	10" x 10" x 11"	6 1/2"	5 7/8"	8 3/4"	8 3/4"
8	400	600	20	12" x 10" x 11"	6 1/2"	7 7/8"	10 3/4"	8 3/4"
10	600	900	25	14" x 12.5" x 13"	6 1/2"	9 7/8"	12 3/4"	11 1/4"
12	800	1200	30	16" x 15" x 13"	6 1/2"	11 7/8"	14 3/4"	13 3/4"
14	1100	1800	38	20" x 17.5" x 17.5"	6 1/2"	13 7/8"	18 3/4"	16 1/4"
16	1500	2200	42	24" x 17.5" x 17.5"	6 1/2"	15 7/8"	22 3/4"	16 1/4"
22	3000	5400	72	34" x 17.5" x 11"	8"	32 1/4" x 15 7/8"	32 3/4"	16 1/4"

Note: All dimensions are in inches with a tolerance of +1/8". Size 22 has a rectangular inlet collar. CFM based on 1000 FPM (Bypass 1500 FPM) for low to medium pressure applications.

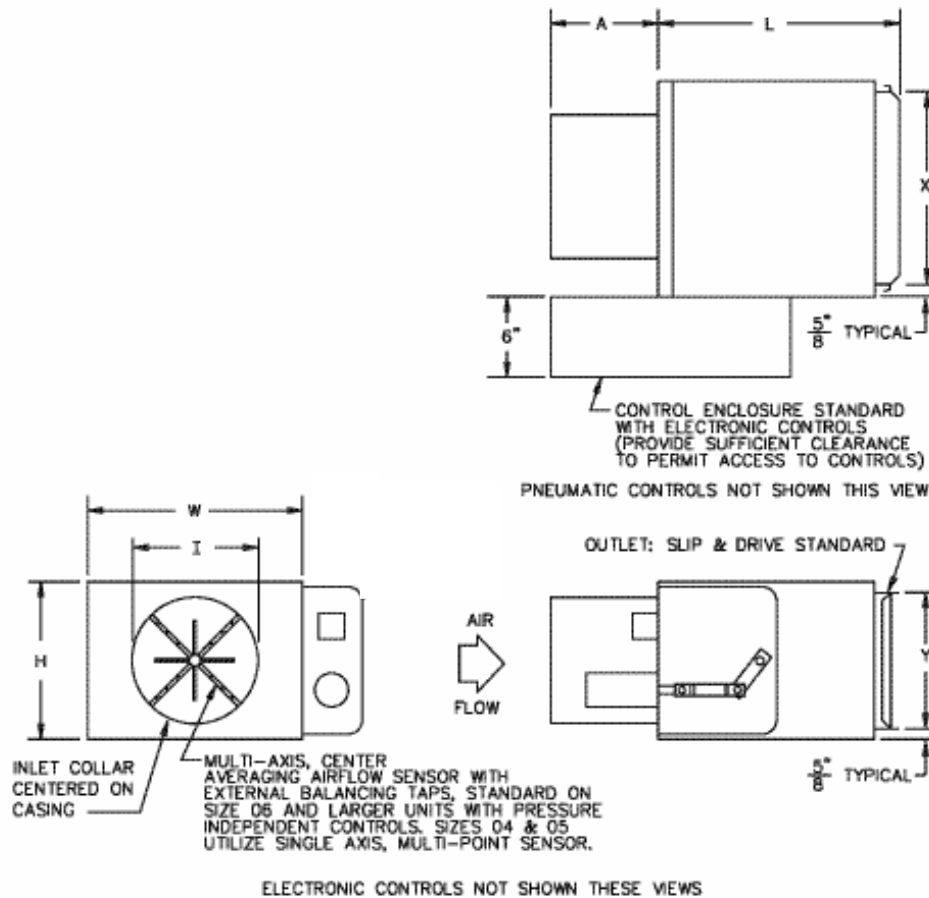

Clearance 24"

Dimensions – Model TSS

Single Duct Variable Air Volume Terminal - Rectangular (Model TSL)

Unit Size	CFM	Bypass CFM	Dimensions				Weight
			A	W	L	X	
10	600	1200	10"	15"	12 1/2"	13 3/4"	26
12	800	1600	14"	19"	12 1/2"	17 3/4"	28
14	1200	2200	20"	25"	16 1/2"	23 3/4"	39
16	1500	3000	26"	31"	16 1/2"	29 3/4"	45

Notes: 1. For dimensional data for unit sizes 6 and 8, refer to the Single Duct Variable Air Volume Terminal (Model TSS). All dimensions are in inches with a tolerance of +1/8". Weights are in pounds. Weights are for the basic unit with the indicated option and control enclosure. Actual weight varies based on project-specific requirements for unit options, appurtenances, and controls. 2. Control enclosure is standard with factory-mounted electronic controls. 3. Check all national and local codes for required clearances.

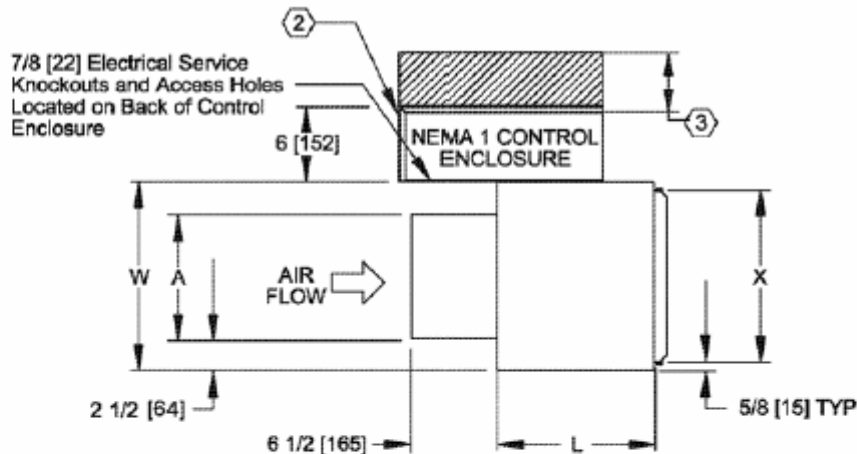

Top View

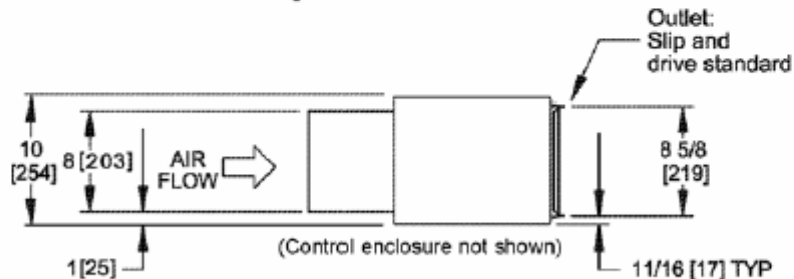

Side View

Dimensions – Model TSL

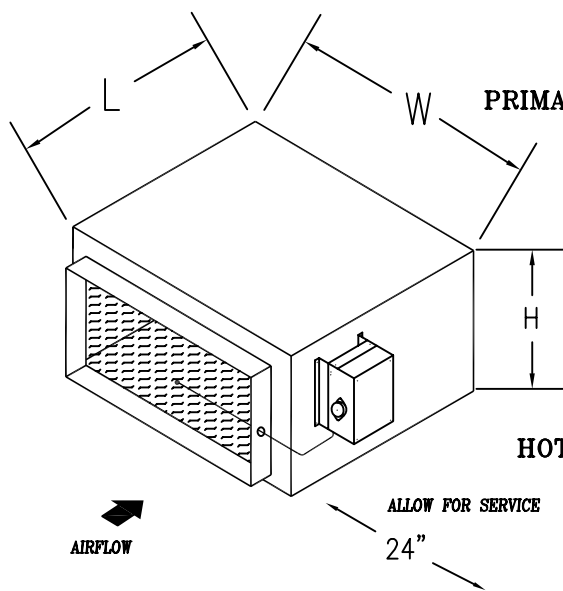

CASING: Minimum 22 gauge galvanized steel reinforced for maximum rigidity and minimum leakage. Units complete with a minimum of 1 inch to 1 1/2 inch density insulation in accordance with NFPR-90

PRIMARY AIR VALVE: Constructed of welded steel channel frame with 18 gauge galvanized steel blades, die formed stiffeners are full blade stop. Stainless steel side seals standard along with blade seals to minimize leakage. All hardware is zinc plated with brass pivot points and bronze oilite bearings.

ACTUATOR: Electronic, manufactured by JCI (FX SERIES),

HOT WATER COIL: Add 4 1/2 inches to airway length for 1 or 2 rows, 1/2 inch SW connection.

NOTES: 1. Dampers may be mounted in any position.
2. Bypass dampers are sized for 100% bypass relief. (see bypass damper selection chart)

35PSA ZONE/BYPASS DAMPER							
MODEL NUMBER	ZONE CFM	BYPASS CFM	INLET + 1/4"	H	W	L	(lbs)
PSA-06-006	600	1000	10 X 9	12	11	13	17
PSA-08-010	1000	2000	16 X 10	12	18	13	23
PSA-10-016	1000	2000	16 X 10	12	18	13	23
PSA-12-022	1500	2500	16 X 10	12	18	13	23
PSA-14-028	2000	4000	29 X 10	12	31	13	38
PSA-16-035	2000	4000	29 X 10	12	31	13	38
PSA-18-050	3000	6000	26 X 16	18	28	22	45
PSA-20-065	4000	8000	32 X 16	18	34	22	51
PSA-24-100	5000	10000	40 X 16	18	42	22	63

*ZONE CFM BASED ON 1000 FPM

*BYPASS CFM BASED ON 2000 FPM

SIZE TO 100% OF UNIT AIRFLOW (MANF. RECOMMENDED)

*PROVIDED BY USACD-YORK

ADDITIONAL DAMPER
SPECIFICATIONS – 35PSA (RECTANGULAR)

SCALE: NONE

STERIL-AIRE®

UVC for HVAC™

Model SE Series UVC Emitters™

Single-Ended, Very High
Output Germicidal Light
Source for HVAC Systems

needed to maintain microbial control. The UVC Emitter, by contrast, has a 12-month service life – and even after a full year, it has 2-1/2 times greater output than competitive devices deliver on Day 1! As a result, only Steril-Aire can ensure the germicidal performance you need, with no return of microbial growth, for 3-4 times longer than the competition.



Applications

Steril-Aire Single-Ended (SE Series) fixtures install from the exterior of HVAC equipment, making them ideal for germicidal sites that are difficult to access. They are easily installed by making a one-inch hole in the equipment wall and/or duct, and then simply mounting the fixture to the unit exterior. Only the lamp or tube penetrates into the system, while the power supply remains external. Choose from six tube lengths (16", 20", 24", 30", 36" and 42") and four voltage options (115, 208, 230 or 277 Vac) to fit most applications, including:

- Fan coils, heat pumps, unit ventilators, terminal units and ductwork.

Benefits

- Kills or inactivates surface and airborne microorganisms that contribute to poor IAQ and/or the spread of infectious disease, including: mold and mold spores, bacteria (*including TB, Legionella, E. coli, Listeria, salmonella and whooping cough*); and viruses (*including colds, flu, measles*).
- Delivers an average of 5 times the output of competitive UVC products at HVAC operating temperatures, for 3-4 times longer life and more reliable germicidal control.
- Uses patented state-of-the-art solid-state electronic power supply for enhanced reliability and performance.
- Continuously cleans coils, drain pans, plenums and ducts, eliminating costly cleaning programs and the use of harmful chemicals and disinfectants.
- Lowers HVAC energy costs by restoring heat transfer and net cooling capacity.
- Produces no ozone or other secondary contaminants – will not harm building occupants, equipment or furnishings.
- Offers lowest life-cycle cost of any UVC product. Return on investment is often less than one year.
- Installs quickly and easily, with no need to open equipment – ideal for small systems and/or ducts.

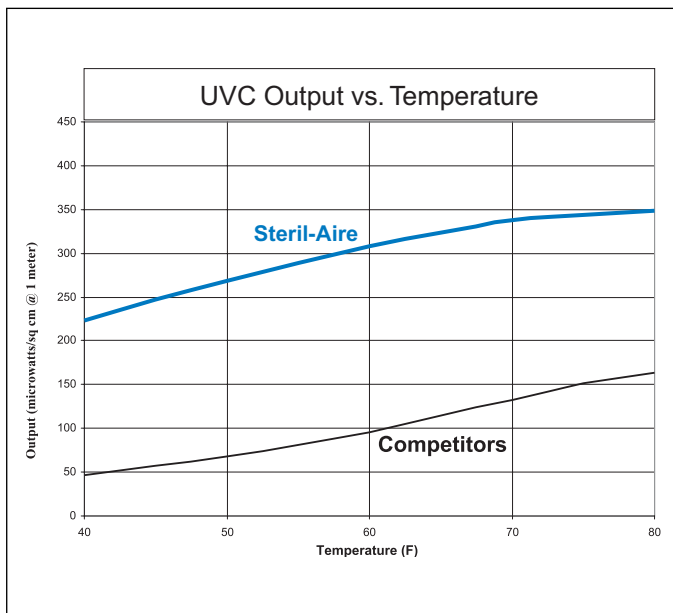

Steril-Aire's multi-patented UVC Emitter™ provides the best and longest-lasting UVC performance available. As shown in the comparison graph (*above*), it has been independently tested to deliver an average of 5 times the output of other ultraviolet devices under HVAC operating conditions (45° F @ 550 fpm air velocity).

Competitive UVC lights must be changed every 3-4 months because they quickly lose the output or "killing power"

Model SE Specifications

The UVC Emitter™ and fixture shall be factory assembled and tested. They shall consist of a housing, power source, Emitter socket and Emitter.

The housing shall be constructed of 304 stainless steel to withstand HVAC environments and shall be equipped with a 1/2" electrical conduit opening to facilitate wiring. All components shall be

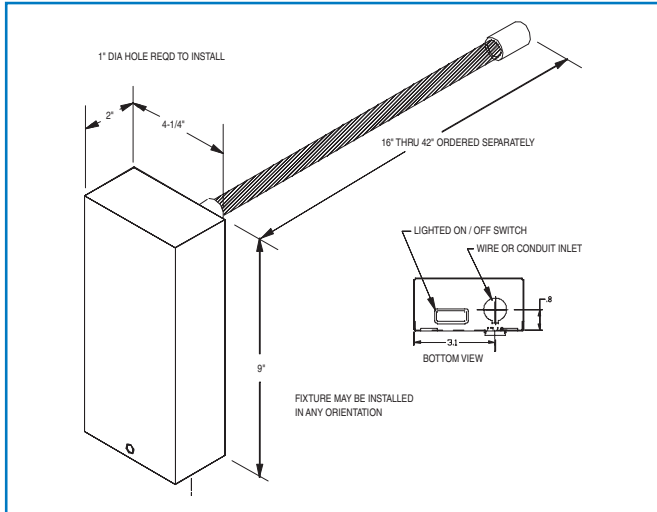

This product may be covered by one or more of the following patents, others pending: 5,334,347/ 5,866,076/ 5,817,276/ 6,372,186/ 6,313,470/ 6,245,293/ 6,267,924/ 6,280,686/ 6,423,882.

incorporated into one integral assembly that maximizes serviceability. It shall be designed for mounting from outside the airstream with only the Emitter in the conditioned air. Emitter shall be held in place and supported in the airstream by a patented integral collar, o-ring and heavy-duty spring wire fastener. The housing shall include an on-off switch and an indicator light to verify unit function.

The power supply shall be a Class P2, electronic rapid start type with a power factor of >0.95 and a power conversion of >75%. It shall be available in 115-208/230 or 277 Vac, 50/60 Hertz, and single phase. It shall be designed to maximize photon production, irradiance and reliability in cold or moving airstreams of 35-170° F, 100% RH and up to 2000 fpm. The design shall include RF and EMI suppression.

The socket shall be a Circline® 4 pin type with sufficient wire length to facilitate service.

The Emitter shall be a very high output, hot cathode, T5 diameter, Circline® cell-base type that produces a UVC band of 250-260 nm. Each tube shall be capable of producing the specified output at up to 2000 fpm velocity and temperatures of 35-170° F. It shall produce no ozone or other secondary contaminants.

Independent testing: The unit shall be tested by an independent test laboratory in accordance with the general provisions of IES Lighting Handbook, 1981 Applications Volume, and shall be verified through independent testing to provide output per 1" arc length of not less than 10 µW/cm² at 1 meter in a 400 fpm airstream of 45° F.

Unit shall comply with UL Standard 1995 for use in HVAC equipment and shall carry the "UL" and "ULC" labels.

Ordering Information

Model No.	Part No.	Description	Length	Electrical	Weight
SE 1 VO	11001900	Single-Ended Fixture	N/A	115, 208, 230V: 70-85 watts	3.0 lb.
SE 1 VO	11002100	Single-Ended Fixture	N/A	277V: 70-85 watts	3.0 lb.
GTS 16 VO	21000100	UVC Emitter	16"	N/A	0.15 lb.
GTS 20 VO	21000200	UVC Emitter	20"	N/A	0.15 lb.
GTS 24 VO	21000300	UVC Emitter	24"	N/A	0.20 lb.
GTS 30 VO	21000400	UVC Emitter	30"	N/A	0.20 lb.
GTS 36 VO	21000500	UVC Emitter	36"	N/A	0.25 lb.
GTS 42 VO	21000600	UVC Emitter	42"	N/A	0.25 lb.

STERIL-AIRE®

Steril-Aire, Inc.

Corporate Office:

2840 N. Lima St.
 Burbank, CA 91504
 Telephone: 800-2STERIL or 818-565-1128
 Fax: 818-565-1129

Website: www.steril-aire.com
 Email: sales@steril-aire.com



Complies with current U.S. and Canadian UL Standards for use in HVAC equipment.

Represented By: