



2 TONS YORK AFFINITY DNX/BHX

Above 2 Tons, please, use ZJ and XP in the next tab.
have the following available benefits and options

Please, specify the following:

- R-410a Refrigerant
- 15 SEER
- Direct Drive Unit
- T2950 365 Days Thermostat
- BAS Networkable with free Web Software
- Freeze protection, High/Low Pressure Switch
- ArmorGuard Stainless Steel 316 Corrosion Protection on coils
- Modulating Economizer
- Fully Welded IBC Calculated Isolation Curb
- Steril-Aire UVC Lights

Please, call us

Samy Rezine	310-420-6767	samy@rezine.net
Karine Leblanc	310-420-7066	karine@rezine.net
Maher Syada	626-255-6406	maher@rezine.net
Michelle Sangalang	626-854-4613	michelle@rezine.net

<http://www.rezine.net>







USAirconditioning

DISTRIBUTORS

The world's largest privately owned HVAC distributor

<http://www.rezine.net>

LINE CARD

 <p>YORK BY JOHNSON CONTROLS</p> <p>Full line of AC & controls www.yorkupg.com</p>	 <p>City Multi & Ductless Mini Splits www.mrslim.com</p>	 <p>Custom Air Handlers allianceairproducts.com</p>
 <p>Fans all sizes www.tcf.com</p>	 <p>Rooftop Accessories www.micrometl.com</p>	 <p>SS316 Corrosion Coating www.armorguards316.com</p>
 <p>UVC lights for HVAC www.steril-aire-usa.com</p>	 <p>Quiet & Efficient High CFM Air Handlers www.miair.com</p>	 <p>Boilers www.raypak.com</p>
 <p>365 Days Various Thermostats www.thermostatusa.com</p>	 <p>Quietest Fan Coil in the Market www.aermec.com</p>	 <p>Multi Fuel Absorption Chillers www.broad.com</p>

samy@rezine.net
310-420-6767

karine@rezine.net
310-420-7066

maher@rezine.net
626-255-6406

michelle@rezine.net
626-854-4613



Heating and Air Conditioning

TECHNICAL GUIDE

R-410A

AFFINITY™ SERIES

2 - 5 TON

60 Hertz

Description

These York® Affinity™ packaged cooling/heating air conditioners are designed for outdoor installation. Only utility and duct connections are required at the point of installation.

The single or two stage gas-fired heaters have aluminized steel tubular heat exchangers and spark to pilot ignition. They are available in natural gas with field conversion to propane.

Field-installed electric heater accessories are available to provide electric heat, if required.

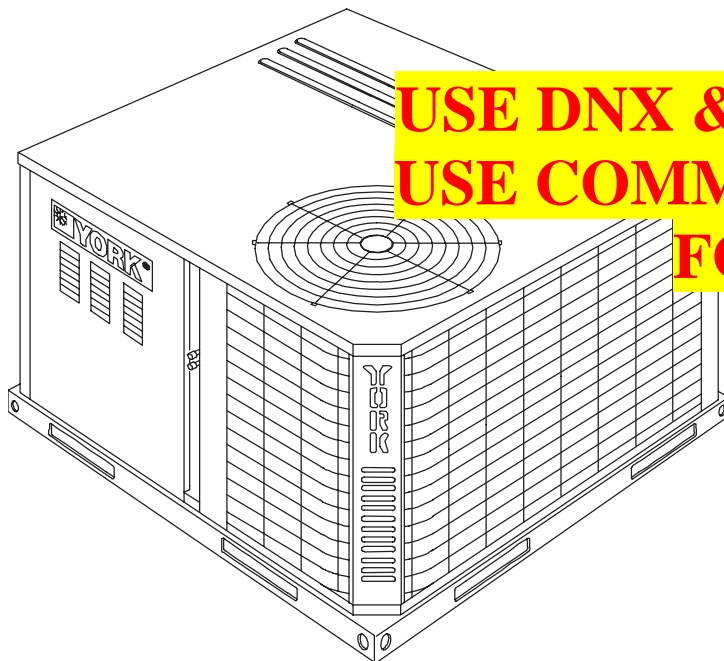

**USE DNX & BHX FOR 2 TONS ONLY
USE COMMERCIAL TYPE ZJ OR XP
FOR 3,4 & 5 TONS**

Tested in accordance with:



ISO 9001
Certified Quality
Management System

Table of Contents

Description	1
Table of Contents	2
Component Location	2
Nomenclature	3
Features and Benefits	4
Guide Specifications	6
Physical Data	8
Capacity Performance	18
Airflow Performance	69
Sound Performance	86
Electrical Data	87
Weights and Dimensions	122

Component Location

Cooling/Gas Unit

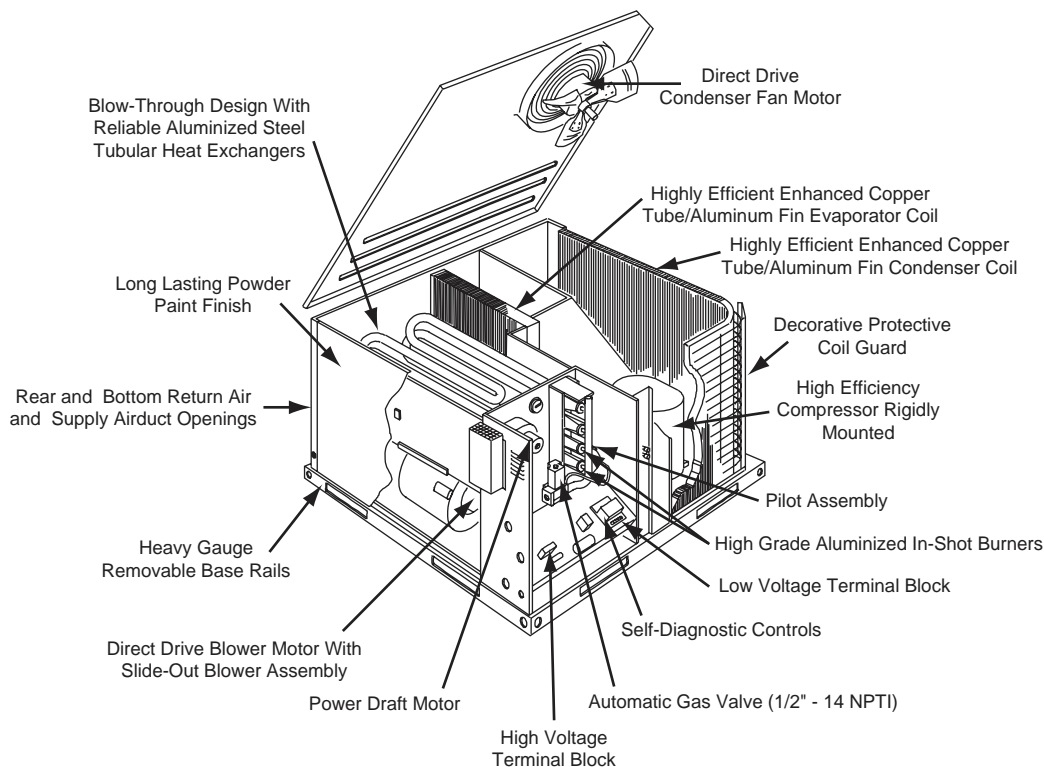

Cooling Only/Heat Pump

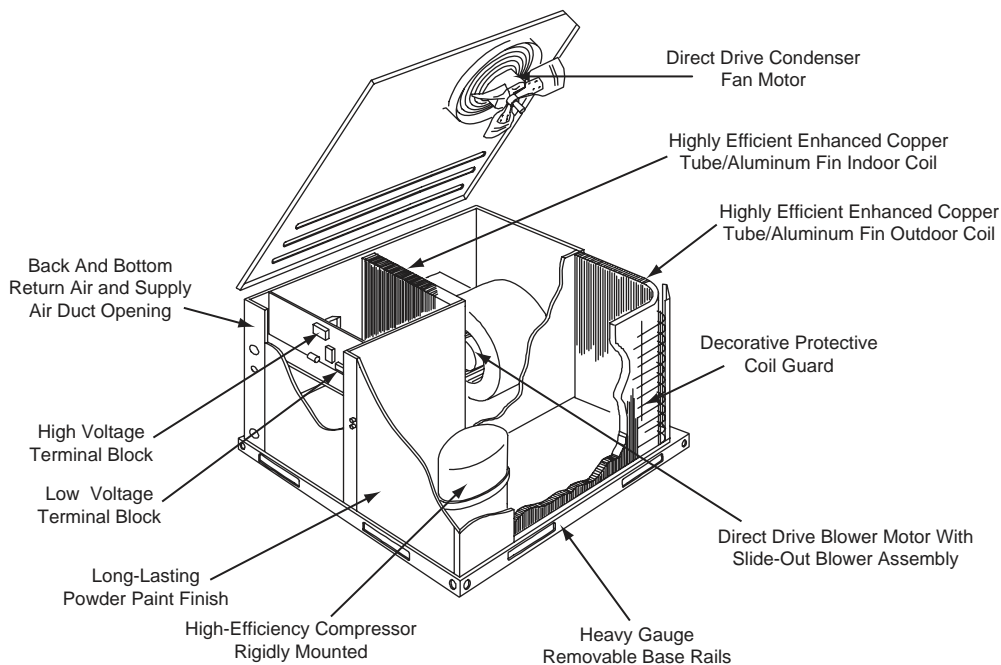

Nomenclature

Cooling/Gas Unit

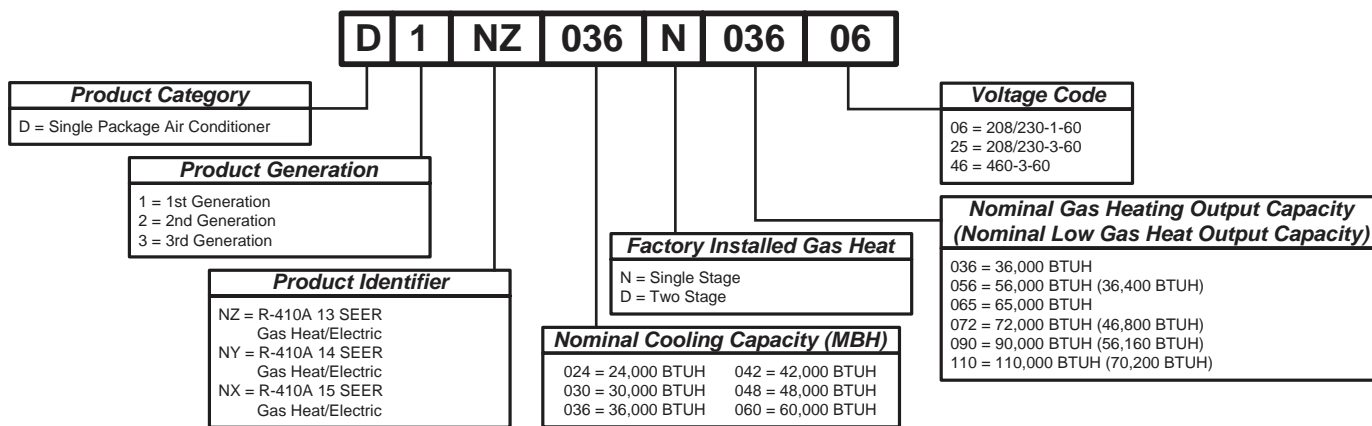

Heat Pump

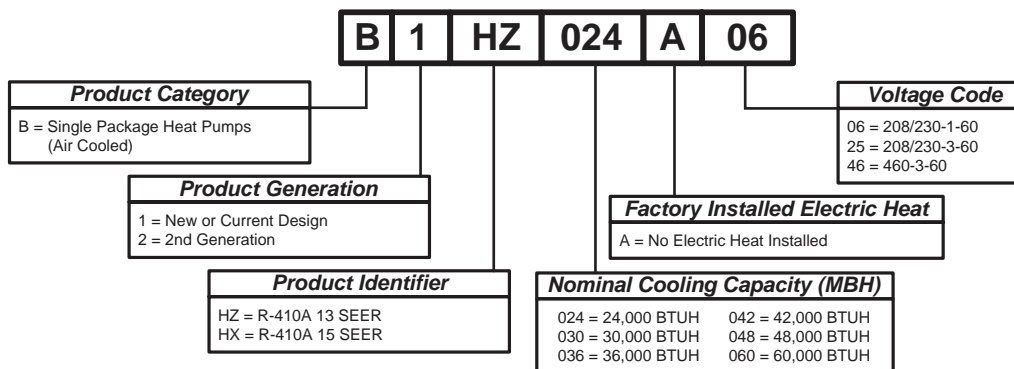

Cooling Only

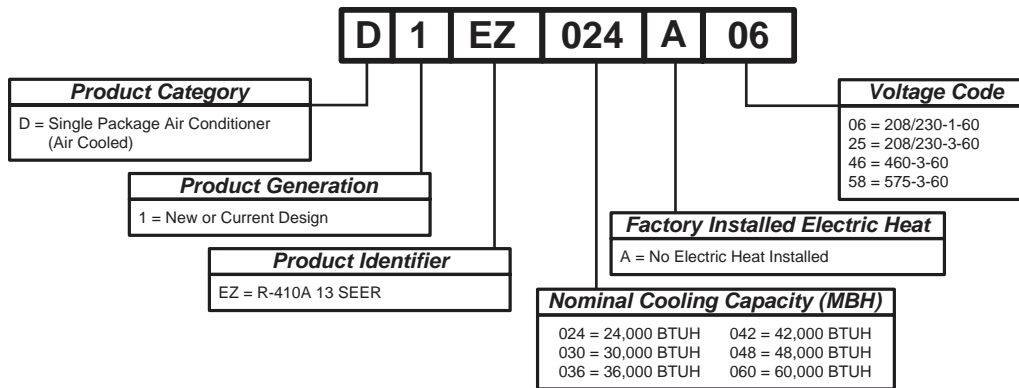

Features and Benefits

Standard Features

- Operating Efficiency** - All gas units provide a minimum AFUE of 80% and SEERS of 13.0 to 16.5. All efficiencies exceed legislated minimum levels.

All heat pump units provide operating efficiencies of 13 to 15 SEER and 7.7 to 8.0 HSPF. All efficiencies exceed legislated minimum levels.
- On Site Flexibility** - All model sizes share a common, compact design cabinet in a single footprint. The installer has the flexibility of setting one curb and placing the proper tonnage unit on that curb after the internal load has been determined. Field convertible duct connections from side shot to down shot allows the installer to have greater flexibility with less inventory.
- Lower Installation Cost** - Installation time and costs are reduced by easy power and control wiring connections. The small base dimension means less space is required on the ground or roof, plus, the installer can fit this unit between the wheel wells of full size pick-up truck.

All units are completely wired, charged with R-410A and tested prior to shipment. Unique test stations using a new state of the art computerized process system are used to insure product quality. Refrigerant charge and component part numbers are verified via computers at assembly. Vital run test statistics such as system pressure, motor currents, air velocity and temperature, unit vibration, and gas system safeties are monitored and recorded by the system to insure unit performance.

Equal size, side supply and return duct connections allows easy hook-up of ducts to match low crawl spaces without transition pieces.
- Utility Connections Made Easy** - Gas and electric utility knockouts are provided through the bottom as well as the side of the unit. Utility connections can be made quickly and with a minimum amount of field labor. A field supplied and field installed electrical disconnect switch must be installed.
- Convertible Airflow Design** - The bottom duct openings are covered when they leave the factory ready to be used for a side supply/side return application. If a bottom

supply/bottom return application is desired, you simply remove the two panels from the bottom of the unit and place them in the side supply/side return duct openings. No panel cutting is required and no accessory panel is necessary. Convertible airflow design allows maximum field flexibility and minimum inventory.

- Condensate Pan** - A non-corrosive, long-lasting, water-tight pan is positioned below the evaporator coil to collect and drain all condensate. Less collection of stagnate condensate will build-up. The condensate pan conforms to ASHRAE 62-89 standards (Ventilation for Acceptable Indoor Air Quality).
- Condensate Drain** - The heavy duty, 3/4 inch NPTI copper connection is more durable over time. The connection is rigidly mounted to assure proper fit and leak tight seal.
- Durable Finish** - With a heavy duty cabinet made of powder-painted, galvanized steel the neutral color blends into surrounding areas. The powdered paint provides a better paint to steel bond, which resists corrosion and rust creep. The special primer formulas and glossy finish insures less fading when exposed to sunlight and offers a more attractive on site appearance. This paint finish meets ASTM-B117 standards for 1000 hours salt spray rating. The highest in the industry.
- Full Perimeter Base Rails** - The easily removable base rails provide a solid foundation for the entire unit and protects the unit during shipment. The rails provide fork lift access from all sides, and rigging holes are also provided so that an overhead crane can be used to place the units on a roof. On applications where the unit is placed on a pad, the base will keep the unit off the pad to deter corrosion. On applications where height is limited, the inch high base rails may be removed on location.
- More Attractive Appearance** - A single piece Water Shed top cover containing a top discharge condenser fan arrangement requires less square footage on installation and provides a wider variety of installations. The one piece design adds greater water integrity. Rounded corners with water drip edges add to the attractive appearance. The cabinet panels have a non-fibrous insulation that will not release insulation fibers into conditioned area.

- **Top Discharge** - The top discharge condenser fan does not disrupt neighboring areas or dry-out vegetation surrounding the unit. The warm air from the top mounted fan is blown up away from the structure and any landscaping. This allows compact location on multi-unit applications.
- **Condenser Coil Grille** - A multi-piece totally enclosed, rigidly mounted condenser coil grille provides protection from objects after installation and provides protection during transit.
- **Low Operating Sound Level** - The upward air flow carries the normal operating noise up and away from the living area. The rigid top panel effectively isolates any motor sound. Isolator mounted compressor and the rippled fins of the condenser coil muffle the normal fan motor and compressor operating sounds. The unique formed base pan also aids in sound alterations with it's Super-Structure design. This design strategically places embossments in the pan for optimum strength and rigidity.
- **Fan System** - All models operate over a wide range of design conditions with an electrically commutated fan motor. These units easily match all types of applications and provide greater on site flexibility to match comfort requirement. The cooling speed is factory set and can be field adjusted to a second speed. The heating speed is factory set to maintain mid point rise at the units heating input, but can be field adjusted. This allows maximum comfort conditions.
- **Simple Control Circuit** - A low voltage printed circuit board contains a diagnostic indicator light and a low voltage terminal strip. An additional set of pin connectors is also provided to simplify the field interface of external controls. Mate-n-lock plug connectors are used. The electrical control box is not located in the compressor compartment. The controls are mounted on a Control-Tilt control panel to allow the access cover to be removed for trouble shooting and maintenance without affecting the normal system operating pressures. All wiring internal to the unit is color/number coded.
- **Protected Compressor** - The compressor is internally protected against high pressure and temperature. This is accomplished by the simultaneous operation of high pressure relief valve and a temperature sensor which protect the compressor if undesirable operating conditions occur.
- **Pressure Switches** - High pressure and low pressure/loss of charge switches standard in all units. When abnormal conditions are sensed through the pressure switches, the unit will lock out preventing any further operation until reset or problem is corrected.
- **Exclusive Coil Design** - Grooved copper tubes and enhanced aluminum fin construction improves heat transfer for maximum efficiency and durability.
- **Heat Exchangers** - Are corrosion-resistant, aluminized-steel tubular construction to provide long-life, trouble-free operation. The unique blow-through design also assures that condensate does not collect in humid areas when in the cooling cycle. This adds to longer heat exchanger life and higher long term efficiencies.
- **Post Purge Induced Draft Combustion** - Exhausts combustion products from the heat exchanger upon completion of the heating cycle to prolong the heat exchanger life.
- **Self Diagnostic Fan Control Module** - Due to this self diagnostic control, less on site time is required to trouble shoot these units.
- **Spark To Pilot Ignition** - Provides faster heat delivery. This ignition is highly reliable, durable and eliminates nuisance lockouts.
- **Multi Port In-shot Burners** - No field adjustment is required to mix the air and gas. These burners are constructed of high-grade corrosion-resistant, aluminized-steel.
- **Low Maintenance** - Long life, permanently lubricated condenser and evaporator fan motor bearings need no annual maintenance adding greater reliability to the unit. Blower assembly can be easily cleaned by the unique Slip- Track slide-out blower assembly.
- **Secured Service Access Ports** - Protected, externally mounted, re-usable service access ports are provided on both the high and low lines for ease of evacuating and charging the system. No final field mounting required.
- **Easy Service Access** - A large, single panel covers the electrical and gas controls makes servicing easy. The blower compartment has an additional large panel with a built-in handle tab. Removing this panel will allow the blower assembly to slide-out for easy removal for maintenance and ease of trouble shooting.
- **Replacement Parts** - The installer requires no special training to replace any of the components of these units and does not need to maintain an inventory of unique parts.
- **System Integration** - Each unit has the internal ability to integrate an electronic air cleaner or humidifier to work in conjunction with the base unit.

Field Installed Accessories

- **Low NOx Kit** - Kit includes all the necessary hardware and instructions to field convert units to reduce emissions to less than 40 nanogram per Joule. California requirement on single phase models only.
- **Propane Conversion Kit** - Kit includes burner orifices, gas valve conversion and installation instructions necessary to field convert unit from natural gas to propane.
- **High Altitude Conversion Kit (Natural Gas/Propane)** - Kit includes all necessary labels and instructions to field alter units with natural gas/propane for installations above 2000 feet. Burner orifices must be obtained from Source 1 Parts. Propane Conversion Kit must be obtained separately.
- **Economizer Down Discharge/Supply Kit** - Modulating integrated economizer provides simultaneous operation between the mechanical cooling and economizer operation. Independent blade design insures proper control and less than 1% leak rate. Includes hood and mesh bird screen filter integrated into the hood, dry bulb

sensor and relief damper. Separate field accessories of single enthalpy and dual enthalpy are also available. A built-in barometric relief of 25% is provided.

- **Single Enthalpy Sensor** - Sensor replaces dry bulb sensor standard in economizer kit. Provides improved economizer operation by sensing the dry bulb temperature from outdoors plus the enthalpy content of the outdoor air.
- **Dual Enthalpy Sensor** - Additional sensor to single enthalpy sensor. Sensor senses both the return air temperature dry bulb and humidity in conjunction with the single enthalpy to determine the most economical mix. Single Enthalpy sensor also required.
- **Hail Guard Kit** - Kit contains protective grilles made of expanded aluminum with full perimeter frame. Sloped hoods are also included to assure maximum protection.
- **Anti Short Cycle Timer (DNZ and BHZ Units Only)** - Automatically prevents the compressor from restarting for 5 minutes after cycled off. Not required if Thermostat 2ET07700224 and 2ET04700224 are used. Standard in all DNX, DNY and BHX units.
- **Filter/Frame Kit (Single Phase Only)** - Kit contains the necessary hardware to field install return air filters into the base unit. Pre-cut filter racks and appropriate cleanable standard size filters are shipped in one kit. The filter rack is suitable for either 1" or 2" filters. (1" filter is supplied) This kit is available for single phase horizontal or vertical duct application only. Standard in all 3 Phase models.
- **Motorized Fresh Air Damper** - Designed for duct mounted side supply/return and unit mounted down supply/return applications. Damper capable of providing 0% through 50% of outdoor air (field supplied). Closes on power loss, includes hood and screen assembly.
- **Rectangle To Round Adapters** - Kit includes one supply and one return air rectangle to round duct adapter. Adapters are preformed and designed to fit over current duct openings on the base unit. Transition is from side square duct opening to 14" round duct opening.
- **Roof Curbs** - NRCA approved curbs provide proper fit to base unit for rooftop installations. Curbs are designed to be assembled through hinge pins in each corner. Kit also provides seal strip to assure a water tight seal. 8 and 14 inch high roof curbs are available.
- **Manual Outdoor Damper** - Provides 0% through 50% outdoor air capability (field adjustable). Designed for duct mounted side supply/return applications. Includes hood and screen assembly.
- **Wall Thermostat** - The units are designed to operate with 24-volt electronic and electro-mechanical thermostats. All units can operate with single stage heat/single stage cool thermostats - with or without the economizer.
- **Low Ambient Kit** - Kit provides necessary hardware to convert unit to operate in cooling cycle down to 0° F. Standard unit operation 45° F.
- **Transformer Kit** - Kit provides necessary hardware to provide single phase models from factory furnished 40 VA

transformer capability to 75 VA transformer capability. (Required on installations with economizer or motorized damper.)

Guide Specifications

General

Units shall be manufactured by York International Unitary Products Group in an ISO 9001 certified facility. YORK's Affinity™ package units give you the flexibility and choices you need in today's market. These packaged cooling/heating air conditioners are designed for outdoor installation. Only utility and duct connections are required at the point of installation. The single or two stage gas fired heaters have aluminized steel tubular heat exchangers and spark to pilot ignition. They are available in natural gas with field conversion to propane.

Description

Units shall be factory-assembled, single packaged, Electric Cooling/Gas Heating units, designed for outdoor mounted installation. For SEER ratings, refer to technical literature. They shall have built in, equal size, field convertible duct connections for down discharge supply/return or horizontal discharge supply/return. The units shall be factory wired, piped, charged with R-410A Refrigerant and factory tested prior to shipment. All unit wiring shall be both numbered and color coded. All units shall be manufactured in a facility certified to ISO 9001 standards, and the cooling performance shall be rated in accordance with DOE and ARI test procedures. The heating performance shall be rated to DOE and GAMA test procedures. Units shall be CSA listed and classified to ANSI Z21.47/CAN/CSA 2.3 standards and UL 1995/CAN/CSA No. 236-M90 conditions.

Unit Cabinet

Unit cabinet shall be constructed of G90 galvanized steel, with exterior surfaces coated with a non-chalking, powdered paint finish, certified at 1000 hours salt spray test per ASTM-B117 standards. The unit top shall be a single piece "Water Shed" design, with drip edges and no-seam corners to provide optimum water integrity. Unit shall have a rigidly mounted condenser coil guard to provide protection from objects and personnel after installation. Indoor blower section shall be insulated with up to 3/4" thick, aluminum, foil faced insulation, fastened to prevent insulation from entering the air stream. Cabinet panels shall be "large" size, easily removable for servicing and maintenance, with built-in lift handles. Unit shall be built on a formed, "Super-Structure" design base pan, with embossments at critical points to add strength, rigidity and aid in minimizing sound. Full perimeter base rails shall be provided to assure reliable transit of equipment, overhead rigging, for truck access and proper sealing on roof curb applications. Base rails shall be removable, when required, to lower unit height. Filters shall be furnished and be accessible through a removable access door, sealed airtight. Units vertical discharge and return duct configuration shall be designed to fit between standard 24" O.C. beams without modification to building

structure, duct work and base unit. Condensate pan shall be internally sloped and conform to ASHRAE 62-89 self-draining standards, with 3/4" NPTI copper, ridged mount connection.

Indoor (Evaporator) Fan Assembly

Fan shall be direct drive design. Fan wheel shall be double-inlet type with forward-curved blades, dynamically balanced to operate smoothly throughout the entire range of operation. Airflow design shall be constant air volume. Bearings shall be sealed and permanently lubricated for longer life and no maintenance. Fan assembly shall be "Slip Track" (slide-out) design for easy removal and cleaning.

Outdoor (Condenser) Fan Assembly

The outdoor fan shall be of the direct-driven propeller type, discharge air vertically, have aluminum blades riveted to corrosion resistant steel spider bracket and shall be statically balanced for smooth operation. The outdoor fan motor shall be totally enclosed with permanently lubricated bearings and internally protected against overload conditions.

Refrigerant Components

Compressors:

- a. Shall be fully hermetic type, direct drive, internally protected with internal high-pressure relief and over temperature protection. The hermetic motor shall be suction gas cooled and have a voltage range of +/- 10% of the unit nameplate voltage.
- b. Shall have internal isolation and sound muffling to minimize vibration and noise, and be externally isolated on a dedicated, independent mounting.

Coils:

- a. Evaporator and condenser coils shall have aluminum plate fins mechanically bonded to seamless internally enhanced copper tubes with all joints brazed.
- b. Evaporator coil shall be of the direct expansion, blow through design, while condenser coil shall be draw through design.

Refrigerant Circuit and Refrigerant Safety Components shall include:

- a. Shall include independent fixed orifice expansion devices.
- b. Shall include filter/strainer to eliminate any foreign matter.

Gas Heating Section (If Equipped)

Heat exchanger and exhaust system shall be constructed of aluminized steel and shall be designed with induced draft combustion with post purge logic and redundant main gas valve. The heat exchanger shall be of the tubular type, constructed of T1-40 aluminized steel for corrosion resistance and allowing minimum mixed air entering temperature of 40 °F. Burners shall be of the in-shot type, constructed of aluminum-coated steel. All gas piping shall enter the unit cabinet at a single location through either the side or bottom, without any field modifications. An integrated control board shall provide timed control of evaporator fan functioning and burner ignition. Heating section shall be provided with the following minimum protection:

- a. Primary and auxiliary high-temperature limit switches.
- b. Induced draft pressure sensor.
- c. Flame roll out switch (manual reset).
- d. Flame proving controls.

Electric Heating Section (Field Install Accessory)

An electric heating section, with nickel chromium elements, shall be provided in a range of 5 thru 25 KW. The heating section shall have a primary limit control(s) (automatic reset) to prevent the heating element system from operating at an excessive temperature. The Heating Section assembly shall slide out of the unit for easy maintenance and service. Units with Electric Heating Sections shall be wired for a single point power supply with branch circuit fusing (where required).

DNX024-048 Single Stage Gas Heat

Component	Models						
	DNX024		DNX036		DNX048		
Nominal Tonnage	2.0		3.0		4.0		
ARI COOLING PERFORMANCE							
Gross Capacity @ ARI A point (Btu)	24.6		38.4		50.0		
ARI net capacity (Btu)	24.0		37.0		48.0		
EER	11.5		12.3		11.2		
SEER	15.0		16.5		15.0		
Nominal CFM	800		1275		1550		
System power (KW)	2.1		3.0		4.3		
Refrigerant type	R-410A		R-410A		R-410A		
Refrigerant charge (lb-oz)	7-8		9-12		9-8		
ARI HEATING PERFORMANCE							
Heating model	36	56	65	90	65	90	110
Heat input (K Btu)	45	70	80	108	80	108	135
Heat output (K Btu)	36	56	64	87	64	87	108
AFUE %	80.0	80.0	80.0	80.0	80.0	80.0	80.0
Steady state efficiency (%)	80	80	80	80	80	80	80
No. burners	2	3	3	4	3	4	5
No. stages	1	1	1	1	1	1	1
Temperature Rise Range (°F)	25-55	30-60	25-55	45-75	25-55	35-65	45-75
Gas Limit Setting (°F)	140	160	140	160	150	170	160
Gas piping connection (in.)	1/2		1/2		1/2		
DIMENSIONS (inches)							
Length	49 1/8		49 1/8		49 1/8		
Width	47 1/4		47 1/4		47 1/4		
Height	33 1/2		41 1/2		41 1/2		
OPERATING WT. (lbs.)							
COMPRESSORS							
Type	Scroll 2-spd		Scroll 2-spd		Scroll 2-spd		
Quantity	1		1		1		
CONDENSER COIL DATA							
Face area (Sq. Ft.)	11.7		14.7		14.7		
Rows	2		2		2		
Fins per inch	20		20		20		
Tube diameter (in.)	3/8		3/8		3/8		
Circuitry Type	Interlaced		Interlaced		Interlaced		
EVAPORATOR COIL DATA							
Face area (Sq. Ft.)	3.4		4.4		4.4		
Rows	2		3		3		
Fins per inch	15		16		16		
Tube diameter	3/8		3/8		3/8		
Circuitry Type	Interlaced		Interlaced		Interlaced		
Refrigerant control	TXV		TXV		TXV		
CONDENSER FAN DATA							
Quantity	1		1		1		
Fan diameter (Inch)	22		22		22		
Type	Prop		Prop		Prop		
Drive type	Direct		Direct		Direct		
No. speeds	1		2		1		
Number of motors	1		1		2		
Motor HP each	1/4		1/3		1/3		
RPM	1100		900/1100		900/1100		
Nominal total CFM	2400		2400		3000		
DIRECT DRIVE EVAP FAN DATA							
Quantity	1		1		1		
Fan Size (Inch)	10 x 8		11 x 10		11 x 10		
Type	Centrifugal		Centrifugal		Centrifugal		
Motor HP each	1/2		1		1		
RPM	Variable		Variable		Variable		
Frame size	48		48		48		
FILTERS							
Quantity - Size	1 - 20 x 20 x 1		2 - 20 x 12 x 1		2 - 20 x 12 x 1		

DNX024-048 Two Stage Gas Heat

Component	Models			
	DNX024	DNX036	DNX048	
Nominal Tonnage	2.0	3.0	4.0	
ARI COOLING PERFORMANCE				
Gross Capacity @ ARI A point (Btu)	24.6	38.4	50.0	
ARI net capacity (Btu)	24.0	37.0	48.0	
EER	11.5	12.3	11.2	
SEER	15.0	16.5	15.0	
Nominal CFM	800	1275	1550	
System power (KW)	2.1	3.0	4.3	
Refrigerant type	R-410A	R-410A	R-410A	
Refrigerant charge (lb-oz)	7-8	9-12	9-8	
ARI HEATING PERFORMANCE				
Heating model	56	90	90	110
Heat input (K Btu)	70/45.5	108/70.2	108/70.2	135/87.8
Heat output (K Btu)	56/36.4	87/56.2	87/56.2	108/70.2
AFUE %	80.0	80.0	80.0	80.0
Steady state efficiency (%)	80	80	80	80
No. burners	3	4	4	5
No. stages	2	2	2	2
Temperature Rise Range (°F)	30-60	45-75	35-65	45-75
Gas Limit Setting (°F)	160	175	170	160
Gas piping connection (in.)	1/2	1/2	1/2	
DIMENSIONS (inches)				
Length	49 1/8	49 1/8	49 1/8	
Width	47 1/4	47 1/4	47 1/4	
Height	33 1/2	41 1/2	41 1/2	
OPERATING WT. (lbs.)				
	440	480	500	
COMPRESSORS				
Type	Scroll 2-spd	Scroll 2-spd	Scroll 2-spd	
Quantity	1	1	1	
CONDENSER COIL DATA				
Face area (Sq. Ft.)	11.7	14.7	14.7	
Rows	2	2	2	
Fins per inch	20	20	20	
Tube diameter (in.)	3/8	3/8	3/8	
Circuitry Type	Interlaced	Interlaced	Interlaced	
EVAPORATOR COIL DATA				
Face area (Sq. Ft.)	3.4	4.4	4.4	
Rows	2	3	3	
Fins per inch	15	16	16	
Tube diameter	3/8	3/8	3/8	
Circuitry Type	Interlaced	Interlaced	Interlaced	
Refrigerant control	TXV	TXV	TXV	
CONDENSER FAN DATA				
Quantity	1	1	1	
Fan diameter (Inch)	22	22	22	
Type	Prop	Prop	Prop	
Drive type	Direct	Direct	Direct	
No. speeds	1	2	1	
Number of motors	1	1	2	
Motor HP each	1/4	1/3	1/3	
RPM	1100	900/1100	900/1100	
Nominal total CFM	2400	2400	3000	
DIRECT DRIVE EVAP FAN DATA				
Quantity	1	1	1	
Fan Size (Inch)	10 x 8	11 x 10	11 x 10	
Type	Centrifugal	Centrifugal	Centrifugal	
Motor HP each	1/2	1	1	
RPM	Variable	Variable	Variable	
Frame size	48	48	48	
FILTERS				
Quantity - Size	1 - 20 x 20 x 1	2 - 20 x 12 x 1	2 - 20 x 12 x 1	

BHX024-060 Physical Data

Component	Models			
	BHX024	BHX036	BHX048	BHX060
Nominal Tonnage	2.0	3.0	4.0	5.0
ARI COOLING PERFORMANCE				
Gross Capacity @ ARI A point (Btu)	24.9	35.3	49.2	58.8
ARI net capacity (Btu)	24.4	34.4	47.0	57.0
EER	12.0	11.5	11.3	11.0
SEER	16	15	15	14.5
Nominal CFM	800	1200	1600	1700
System power (KW)	2.0	3.0	4.2	5.2
Refrigerant type	R410a	R410a	R410a	R410a
Refrigerant charge (lb-oz)	7-10	10-4	12-4	12-0
ARI HEATING PERFORMANCE				
47°F Capacity Rating (Mbh)	19.8	33.0	45.0	55.0
System Power (Kw/COP)	3.5	3.1	3.0	3.1
17°F Capacity Rating (Mbh)	11.1	18.9	27.2	32.4
System Power (Kw/COP)	2.1	2.0	2.1	2.1
HSPF (BTU/Watts-hr.)	8.0	8.0	8.0	8.0
DIMENSIONS (inches)				
Length	49 1/8	49 1/8	49 1/8	49 1/8
Width	47 1/4	47 1/4	47 1/4	47 1/4
Height	33 1/2	33 1/2	41 1/2	41 1/2
OPERATING WT. (lbs.)	350	400	440	460
COMPRESSORS				
Type	Scroll 2-spd	Scroll 2-spd	Scroll 2-spd	Scroll 2-spd
Quantity	1	1	1	1
CONDENSER COIL DATA				
Face area (Sq. Ft.)	11.7	11.7	16.4	16.4
Rows	1	2	2	2
Fins per inch	20	20	20	20
Tube diameter (in.)	3/8	3/8	3/8	3/8
Circuitry Type	Interlaced	Interlaced	Interlaced	Interlaced
Refrigerant control	Orifice	TXV	TXV	TXV
EVAPORATOR COIL DATA				
Face area (Sq. Ft.)	4.38	4.38	5.63	5.63
Rows	3	3	3	3
Fins per inch	15	15	16	16
Tube diameter	3/8	3/8	3/8	3/8
Circuitry Type	Interlaced	Interlaced	Interlaced	Interlaced
Refrigerant control	TXV	TXV	TXV	TXV
CONDENSER FAN DATA				
Fan diameter (Inch)	22	22	22	22
Type	Axial	Axial	Axial	Axial
Drive type	Direct	Direct	Direct	Direct
No. speeds	2	1	2	2
Number of motors	1	1	1	1
Motor HP each	1/3	1/4	1/3	1/3
RPM	850/1100	1100	900/1100	950/1100
Nominal total CFM	2400	2400	3000	3000
DIRECT DRIVE EVAP FAN DATA				
Quantity	1	1	1	1
Fan Size (Inch)	10 x 8	11 x 10	11 x 10	11 x 10
Type	Centrifugal	Centrifugal	Centrifugal	Centrifugal
No. speeds	1	1	1	1
Motor HP each	1/2	3/4	3/4	1
RPM	Variable	Variable	Variable	Variable
Frame size	48	48	48	48
FILTERS				
Quantity - Size	2 - 22 x 14 x 1	2 - 22 x 14 x 1	2 - 22 x 14 x 1	2 - 22 x 14 x 1

DNX024-048 Cooling Capacities

DNX024 (2.0 Ton)

Air on Evaporator Coil		Temperature of Air on Condenser Coil															
CFM	WB (°F)	Net Capacity ¹ (MBh)	Total Input (kW) ²	Sensible Capacity (MBh)						Net Capacity ¹ (MBh)	Total Input (kW) ²	Sensible Capacity (MBh)					
				Return Dry Bulb (°F)								Return Dry Bulb (°F)					
				90	85	80	75	70	65			90	85	80	75	70	65
				75°F						85°F							
600	77	24.9	1.2	11.4	8.7	9.0	-	-	-	23.6	1.3	11.9	10.1	8.3	-	-	
	72	22.8	1.1	16.1	13.0	11.8	9.7	-	-	21.4	1.3	15.6	13.4	11.2	9.0	-	
	67	20.8	1.1	20.8	17.3	14.7	12.1	9.5	-	19.2	1.3	19.2	16.7	14.0	11.4	8.7	
	62	18.3	1.1	18.3	18.3	17.7	13.7	9.8	5.8	17.2	1.3	17.2	17.2	16.9	12.8	8.8	4.7
	57	19.5	1.0	19.5	19.5	19.4	15.1	10.9	6.6	17.8	1.2	17.8	17.8	17.7	13.5	9.3	5.1
800	77	32.1	1.8	15.1	13.3	10.8	-	-	-	30.6	2.0	15.6	12.9	10.3	-	-	
	72	29.8	1.8	21.1	18.2	15.3	12.4	-	-	28.2	1.9	20.6	17.6	14.6	11.6	-	
	67	27.4	1.7	27.1	23.0	19.7	16.5	13.2	-	25.7	1.9	25.5	22.2	18.9	15.7	12.4	
	62	25.0	1.7	25.0	25.0	24.2	20.8	17.4	14.0	23.6	1.8	23.6	23.6	23.1	19.7	16.2	12.8
	57	25.6	1.7	25.6	25.6	25.6	21.9	18.1	14.3	23.9	1.9	23.9	23.9	23.7	20.1	16.5	12.9
				95°F						105°F							
600	77	22.3	1.5	12.5	11.4	7.6	-	-	-	20.1	1.7	13.0	8.7	6.8	-	-	
	72	19.9	1.5	15.1	13.7	10.5	8.2	-	-	18.0	1.7	14.5	11.4	9.8	7.4	-	
	67	17.6	1.4	17.6	16.0	13.4	10.7	8.0	-	15.9	1.6	15.9	14.1	12.7	9.1	5.6	
	62	16.1	1.4	16.1	16.1	16.1	11.9	7.7	3.6	14.6	1.6	14.6	14.6	15.1	10.8	5.9	2.3
	57	16.1	1.4	16.1	16.1	15.9	11.8	7.7	3.6	14.9	1.6	14.9	14.7	14.6	11.2	7.8	4.3
800	77	29.2	2.1	16.1	12.5	9.8	-	-	-	26.9	2.4	17.0	11.9	9.0	-	-	
	72	26.6	2.1	20.1	17.0	14.0	10.9	-	-	24.4	2.3	19.4	16.3	13.2	10.0	-	
	67	24.0	2.1	24.0	21.5	18.2	14.8	11.5	-	21.9	2.3	21.9	20.7	17.3	13.9	10.5	
	62	22.2	2.0	22.2	22.2	22.1	18.6	15.1	11.5	20.3	2.3	20.3	20.3	21.0	17.4	13.8	10.1
	57	22.2	2.0	22.2	22.2	21.7	18.3	14.9	11.5	20.7	2.3	20.7	20.7	20.1	16.6	13.1	9.6
				115°F													
600	77	18.0	1.9	13.5	6.0	6.0	-	-	-								
	72	16.1	1.9	13.9	9.0	9.0	6.6	-	-								
	67	14.3	1.8	14.3	12.1	12.1	7.6	3.1	-								
	62	13.1	1.8	13.1	13.1	14.1	9.7	4.1	1.0								
	57	13.8	1.8	13.8	13.3	13.3	10.5	7.8	5.1								
800	77	24.5	2.6	17.8	11.4	8.3	-	-	-								
	72	22.2	2.6	18.8	15.6	12.4	9.1	-	-								
	67	19.8	2.5	19.8	19.8	16.5	13.0	9.4	-								
	62	18.5	2.5	18.5	18.5	19.9	16.2	12.5	8.7								
	57	19.2	2.5	19.2	19.2	18.5	14.9	11.3	7.6								

1. These capacities are Net Capacities.
2. These ratings include the compressor, condenser fan and supply air blower motors.

DNX036 (3.0 Ton)

Air on Evaporator Coil		Temperature of Air on Condenser Coil																	
		Net Capacity ¹ (MBh)	Total Input (kW) ²	Sensible Capacity (MBh)						Net Capacity ¹ (MBh)	Total Input (kW) ²	Sensible Capacity (MBh)							
				Return Dry Bulb (°F)								Return Dry Bulb (°F)							
CFM	WB (°F)			90	85	80	75	70	65			90	85	80	75	70	65		
		75°F									85°F								
925	77	35.2	1.5	20.9	13.3	11.6	-	-	-	33.3	1.7	21.2	15.1	11.3	-	-	-		
	72	32.3	1.5	25.2	20.0	17.0	12.9	-	-	30.4	1.7	24.4	20.3	16.3	12.3	-	-		
	67	29.5	1.5	29.5	26.8	22.4	18.1	13.8	-	27.5	1.7	27.5	25.5	21.4	17.2	13.0	-		
	62	26.8	1.5	26.8	26.8	27.2	22.5	17.8	13.2	25.1	1.7	25.1	25.1	25.1	20.8	16.5	12.2		
	57	28.2	1.6	28.2	28.2	25.4	21.2	17.0	12.8	25.9	1.8	25.9	25.9	24.2	20.0	15.9	11.7		
1275	77	48.7	2.8	23.8	19.3	14.7	-	-	-	46.5	3.0	25.5	19.4	14.7	-	-	-		
	72	45.7	2.6	33.3	28.3	23.2	18.2	-	-	43.2	2.9	32.7	27.6	22.5	17.3	-	-		
	67	42.8	2.5	42.8	37.2	31.7	26.1	20.6	-	39.9	2.8	39.9	35.8	30.2	24.6	19.0	-		
	62	38.0	2.3	38.0	38.0	34.6	29.8	24.9	20.0	36.7	2.6	36.7	36.7	34.0	28.7	23.5	18.3		
	57	38.4	2.5	38.4	38.4	35.9	30.3	24.7	19.1	36.7	2.8	36.7	36.7	34.4	28.8	23.1	17.5		
		95°F									105°F								
925	77	31.5	1.9	21.5	17.0	11.0	-	-	-	29.0	2.2	21.9	13.1	10.1	-	-	-		
	72	28.5	1.9	23.6	20.7	15.6	11.7	-	-	26.2	2.2	22.7	17.3	14.8	10.9	-	-		
	67	25.6	1.9	25.6	24.3	20.3	16.2	12.2	-	23.4	2.2	23.4	21.5	19.5	15.4	11.3	-		
	62	23.4	1.9	23.4	23.4	23.0	19.1	15.1	11.2	21.5	2.2	21.5	21.5	21.3	17.3	12.3	9.4		
	57	23.6	1.9	23.6	23.6	22.9	18.8	14.8	10.7	22.3	2.2	22.3	21.6	21.3	17.2	13.2	9.2		
1275	77	44.4	3.2	27.2	19.4	14.7	-	-	-	41.3	3.5	27.9	18.8	13.7	-	-	-		
	72	40.7	3.1	32.1	26.9	21.7	16.5	-	-	37.8	3.4	31.1	25.9	20.7	15.4	-	-		
	67	37.0	3.1	37.0	34.3	28.7	23.1	17.4	-	34.3	3.4	34.3	33.0	27.6	22.0	16.3	-		
	62	35.4	2.9	35.4	35.4	33.3	27.7	22.1	16.5	32.4	3.3	32.4	32.4	31.4	25.6	19.8	14.1		
	57	35.0	3.0	35.0	35.0	32.9	27.2	21.6	15.9	33.0	3.3	33.0	33.0	31.1	25.4	19.6	13.9		
		115°F																	
925	77	26.5	2.4	22.3	9.2	9.2	-	-	-										
	72	23.9	2.4	21.8	14.0	14.0	10.1	-	-										
	67	21.3	2.4	21.3	18.7	18.7	14.6	10.4	-										
	62	19.6	2.4	19.6	19.6	19.6	15.6	9.6	7.7										
	57	21.0	2.4	21.0	19.7	19.7	15.7	11.7	7.6										
1275	77	38.3	3.8	28.6	18.1	12.8	-	-	-										
	72	35.0	3.8	30.2	24.9	19.6	14.4	-	-										
	67	31.7	3.7	31.7	31.7	26.5	20.8	15.2	-										
	62	29.5	3.6	29.5	29.5	29.5	23.5	17.6	11.6										
	57	30.9	3.6	30.9	30.9	29.4	23.5	17.7	11.8										

1. These capacities are Net Capacities.
2. These ratings include the compressor, condenser fan and supply air blower motors.

DNX048 (4.0 Ton)

Air on Evaporator Coil		Temperature of Air on Condenser Coil																	
		Net Capacity ¹ (MBh)	Total Input (kW) ²	Sensible Capacity (MBh)						Net Capacity ¹ (MBh)	Total Input (kW) ²	Sensible Capacity (MBh)							
				Return Dry Bulb (°F)								Return Dry Bulb (°F)							
CFM	WB (°F)			90	85	80	75	70	65			90	85	80	75	70	65		
		75°F									85°F								
1000	77	45.3	2.2	23.2	17.3	14.8	-	-	-	42.8	2.5	22.7	18.4	14.2	-	-	-		
	72	42.0	2.2	29.7	24.2	20.6	16.0	-	-	39.6	2.5	28.9	24.3	19.8	15.2	-	-		
	67	38.8	2.2	36.3	31.1	26.3	21.5	16.7	-	36.4	2.5	35.1	30.2	25.3	20.5	15.6	-		
	62	34.4	2.2	34.4	34.4	31.7	27.3	22.8	18.4	32.4	2.5	32.4	32.4	30.7	26.2	21.7	17.2		
	57	33.6	2.2	33.6	33.6	33.0	28.4	23.8	19.2	31.7	2.4	31.7	31.7	31.2	26.6	21.9	17.3		
1550	77	64.7	3.9	31.1	26.6	20.8	-	-	-	60.7	4.2	31.0	25.2	19.4	-	-	-		
	72	59.6	3.8	42.0	35.7	29.4	23.2	-	-	56.0	4.1	40.7	34.4	28.1	21.7	-	-		
	67	54.5	3.7	52.9	44.9	38.1	31.2	24.4	-	51.2	4.0	50.4	43.6	36.8	29.9	23.1	-		
	62	50.3	3.5	50.3	50.3	46.3	39.4	32.4	25.5	47.6	3.8	47.6	47.6	44.4	37.5	30.5	23.6		
	57	48.8	3.5	48.8	48.8	48.3	41.5	34.7	27.9	46.5	3.7	46.5	46.5	46.3	39.3	32.3	25.4		
		95°F									105°F								
1000	77	40.4	2.8	22.2	19.6	13.5	-	-	-	37.5	3.1	23.2	15.4	12.4	-	-	-		
	72	37.2	2.8	28.1	24.4	18.9	14.4	-	-	34.3	3.1	27.2	20.6	17.9	13.2	-	-		
	67	34.0	2.8	34.0	29.3	24.4	19.4	14.4	-	31.1	3.1	31.1	25.8	23.3	18.6	13.8	-		
	62	30.5	2.7	30.5	30.5	29.6	25.0	20.5	15.9	28.0	3.1	28.0	28.0	27.7	23.1	18.1	13.8		
	57	29.8	2.7	29.8	29.8	29.4	24.7	20.0	15.4	28.0	3.0	28.0	27.9	27.7	22.8	17.9	13.0		
1550	77	56.8	4.5	30.9	23.8	17.9	-	-	-	52.1	4.9	32.0	22.7	16.7	-	-	-		
	72	52.4	4.4	39.4	33.1	26.7	20.3	-	-	48.4	4.7	38.4	31.9	25.5	19.0	-	-		
	67	48.0	4.3	48.0	42.3	35.5	28.6	21.8	-	44.8	4.6	44.8	41.2	34.2	27.2	20.2	-		
	62	44.8	4.1	44.8	44.8	42.6	35.6	28.6	21.6	42.0	4.4	42.0	42.0	40.4	33.4	26.4	19.3		
	57	44.3	4.0	44.3	44.3	44.3	37.1	30.0	22.8	41.9	4.4	41.9	41.9	41.0	33.9	26.7	19.6		
		115°F																	
1000	77	34.7	3.5	24.2	11.2	11.2	-	-	-										
	72	31.5	3.5	26.2	16.8	16.8	12.0	-	-										
	67	28.2	3.4	28.2	22.3	22.3	17.8	13.3	-										
	62	25.4	3.4	25.4	25.4	25.8	21.1	15.8	11.7										
	57	26.3	3.4	26.3	25.9	25.9	20.9	15.8	10.7										
1550	77	47.4	5.3	33.2	21.6	15.5	-	-	-										
	72	44.5	5.1	37.4	30.8	24.2	17.6	-	-										
	67	41.6	5.0	41.6	40.0	32.9	25.8	18.7	-										
	62	39.2	4.8	39.2	39.2	38.2	31.2	24.1	17.0										
	57	39.4	4.8	39.4	39.4	37.8	30.6	23.5	16.3										

1. These capacities are Net Capacities.
2. These ratings include the compressor, condenser fan and supply air blower motors.

BHX024-060 Cooling Capacities

BHX024 (2.0 Ton)

Air on Evaporator Coil		Temperature of Air on Condenser Coil																	
CFM	WB (°F)	Net Capacity ¹ (MBh)	Total Input (kW) ²	Sensible Capacity (MBh)						Net Capacity ¹ (MBh)	Total Input (kW) ²	Sensible Capacity (MBh)							
				Return Dry Bulb (°F)								Return Dry Bulb (°F)							
				90	85	80	75	70	65			90	85	80	75	70	65		
		75°F									85°F								
600	77	26.8	1.1	14.8	11.4	8.4	-	-	-	24.6	1.2	15.2	10.8	7.8	-	-			
	72	24.1	1.1	18.1	15.0	12.0	9.0	-	-	22.1	1.2	17.4	14.4	11.3	8.3	-			
	67	21.4	1.0	21.4	18.7	15.6	12.6	9.6	-	19.7	1.2	19.7	17.9	14.9	11.8	8.8			
	62	19.6	1.1	19.6	19.6	19.1	16.1	13.0	10.0	18.1	1.2	18.1	18.1	17.8	14.7	11.7	8.6		
	57	19.4	1.1	19.4	19.4	19.2	16.2	13.1	10.1	17.9	1.2	17.9	17.9	17.7	14.6	11.6	8.5		
800	77	34.1	1.8	17.5	15.3	11.6	-	-	-	32.0	1.9	18.3	14.5	10.8	-	-			
	72	31.3	1.7	23.0	19.3	15.6	12.0	-	-	29.2	1.9	22.3	18.6	14.9	11.2	-			
	67	28.5	1.6	28.5	23.3	19.7	16.0	12.3	-	26.4	1.8	26.4	22.7	19.0	15.3	11.6			
	62	25.3	1.6	25.3	25.3	24.8	21.1	17.4	13.8	23.6	1.8	23.6	23.6	23.2	19.5	15.8	12.1		
	57	25.0	1.6	25.0	25.0	25.1	21.4	17.8	15.0	23.6	1.8	23.6	23.6	23.4	19.7	16.0	12.7		
		95°F									105°F								
600	77	22.4	1.4	15.5	10.2	7.2	-	-	-	20.7	1.6	17.3	12.0	6.6	-	-			
	72	20.2	1.4	16.8	13.7	10.6	7.5	-	-	18.3	1.6	16.6	13.8	9.9	6.1	-			
	67	18.0	1.4	18.0	17.2	14.1	11.0	7.9	-	16.0	1.6	16.0	15.5	13.3	9.5	5.6			
	62	16.7	1.4	16.7	16.7	16.4	13.4	10.3	7.2	15.3	1.6	15.3	15.3	15.2	11.4	7.6	7.2		
	57	16.5	1.4	16.5	16.5	16.2	13.1	10.0	7.0	15.0	1.6	15.0	15.0	14.7	10.8	7.0	7.0		
800	77	29.8	2.1	19.0	13.8	10.0	-	-	-	27.3	2.4	19.6	13.1	9.1	-	-			
	72	27.1	2.1	21.7	17.9	14.2	10.4	-	-	24.8	2.3	20.9	17.1	13.3	9.5	-			
	67	24.4	2.0	24.4	22.1	18.4	14.6	10.8	-	22.3	2.3	22.3	21.1	17.5	13.7	9.9			
	62	22.0	2.0	22.0	22.0	21.7	17.9	14.1	10.4	20.4	2.3	20.4	20.4	20.1	16.3	12.5	8.7		
	57	22.3	2.0	22.3	22.3	21.7	17.9	14.1	10.4	20.7	2.3	20.7	20.7	20.1	16.3	12.5	8.7		
		115°F																	
600	77	19.0	1.8	19.0	13.8	6.1	-	-	-										
	72	16.5	1.8	16.5	13.8	9.3	4.7	-	-										
	67	13.9	1.8	13.9	13.9	12.5	7.9	3.4	-										
	62	13.9	1.8	13.9	13.9	13.9	9.4	4.8	-										
	57	13.5	1.9	13.5	13.5	13.1	8.6	4.0	-										
800	77	24.8	2.6	20.1	12.4	8.3	-	-	-										
	72	22.5	2.6	20.1	16.3	12.4	8.6	-	-										
	67	20.1	2.6	20.1	20.1	16.6	12.8	8.9	-										
	62	18.8	2.5	18.8	18.8	18.6	14.7	10.9	7.0										
	57	19.1	2.5	19.1	19.1	18.6	14.7	10.9	7.0										

1. These capacities are Net Capacities.
2. These ratings include the compressor, condenser fan and supply air blower motors.

BHX036 (3.0 Ton)

Air on Evaporator Coil		Temperature of Air on Condenser Coil																	
		Net Capacity ¹ (MBh)	Total Input (kW) ²	Sensible Capacity (MBh)						Net Capacity ¹ (MBh)	Total Input (kW) ²	Sensible Capacity (MBh)							
				Return Dry Bulb (°F)								Return Dry Bulb (°F)							
CFM	WB (°F)			90	85	80	75	70	65			90	85	80	75	70	65		
		75°F									85°F								
900	77	36.8	1.5	20.7	16.2	11.9	-	-	-	34.2	1.7	21.5	15.2	11.0	-	-	-		
	72	33.8	1.5	25.7	21.5	17.3	13.1	-	-	31.0	1.8	24.7	20.5	16.3	12.1	-	-		
	67	30.8	1.5	30.8	26.8	22.6	18.4	14.2	-	27.9	1.8	27.9	25.8	21.6	17.4	13.2	-		
	62	28.3	1.5	28.3	28.3	28.3	24.1	19.8	15.6	26.1	1.8	26.1	26.1	26.1	21.9	17.7	13.5		
	57	28.1	1.5	28.1	28.1	28.2	23.9	19.7	15.5	26.3	1.7	26.3	26.3	26.2	22.0	17.8	13.6		
1200	77	49.8	2.7	24.5	20.9	15.9	-	-	-	46.0	2.9	24.9	19.4	14.5	-	-	-		
	72	44.7	2.6	32.0	27.1	22.1	17.2	-	-	41.5	2.8	30.9	26.0	21.0	16.0	-	-		
	67	39.5	2.4	39.5	33.3	28.4	23.4	18.5	-	37.0	2.7	37.0	32.5	27.5	22.5	17.6	-		
	62	36.5	2.3	36.5	36.5	35.8	30.9	25.9	21.0	34.2	2.6	34.2	34.2	33.9	28.9	23.9	18.9		
	57	36.6	2.3	36.6	36.6	36.5	31.5	26.6	23.9	34.3	2.6	34.3	34.3	34.2	29.2	24.2	20.4		
		95°F									105°F								
900	77	31.5	2.0	22.4	14.2	10.1	-	-	-	28.3	2.2	23.1	14.7	9.0	-	-	-		
	72	28.2	2.0	23.7	19.5	15.3	11.2	-	-	25.3	2.3	22.8	18.5	14.3	10.1	-	-		
	67	25.0	2.0	25.0	24.8	20.6	16.4	12.2	-	22.4	2.3	22.4	22.3	19.6	15.3	11.1	-		
	62	24.0	2.0	24.0	24.0	24.0	19.8	15.7	11.5	21.7	2.2	21.7	21.7	21.8	17.5	13.3	9.0		
	57	24.5	2.0	24.5	24.5	24.2	20.0	15.8	11.7	22.4	2.2	22.4	22.4	22.0	17.8	13.6	9.3		
1200	77	42.1	3.1	25.3	18.0	13.0	-	-	-	37.9	3.4	25.6	17.1	12.2	-	-	-		
	72	38.2	3.0	29.9	24.8	19.8	14.8	-	-	34.6	3.4	28.5	23.6	18.7	13.8	-	-		
	67	34.4	3.0	34.4	31.7	26.7	21.7	16.7	-	31.4	3.3	31.4	30.0	25.2	20.3	15.4	-		
	62	31.9	2.9	31.9	31.9	31.9	26.9	21.9	16.9	29.5	3.2	29.5	29.5	29.5	24.6	19.7	14.8		
	57	31.9	2.9	31.9	31.9	31.9	26.9	21.9	16.9	29.6	3.2	29.6	29.6	29.6	24.7	19.8	14.9		
		115°F																	
900	77	25.0	2.5	23.8	15.2	8.0	-	-	-										
	72	22.5	2.5	21.9	17.6	13.3	9.0	-	-										
	67	19.9	2.5	19.9	19.9	18.5	14.2	9.9	-										
	62	19.5	2.5	19.5	19.5	19.5	15.2	10.9	6.6										
	57	20.4	2.5	20.4	20.4	19.9	15.6	11.3	7.0										
1200	77	33.7	3.8	25.8	16.3	11.4	-	-	-										
	72	31.0	3.7	27.1	22.3	17.5	12.7	-	-										
	67	28.4	3.7	28.4	28.4	23.7	18.9	14.1	-										
	62	27.1	3.6	27.1	27.1	27.1	22.4	17.6	12.8										
	57	27.3	3.6	27.3	27.3	27.3	22.5	17.7	12.9										

1. These capacities are Net Capacities.
2. These ratings include the compressor, condenser fan and supply air blower motors.

BHX048 (4.0 Ton)

Air on Evaporator Coil		Temperature of Air on Condenser Coil															
CFM	WB (°F)	Net Capacity ¹ (MBh)	Total Input (kW) ²	Sensible Capacity (MBh)						Net Capacity ¹ (MBh)	Total Input (kW) ²	Sensible Capacity (MBh)					
				Return Dry Bulb (°F)								Return Dry Bulb (°F)					
				90	85	80	75	70	65			90	85	80	75	70	65
				75°F						85°F							
1050	77	47.4	2.2	25.0	20.4	15.4	-	-	-	43.6	2.4	24.5	19.1	14.1	-	-	-
	72	42.5	2.2	31.3	26.3	21.3	16.3	-	-	39.6	2.5	30.0	25.0	19.9	14.9	-	-
	67	37.6	2.3	37.6	32.1	27.1	22.1	17.1	-	35.5	2.6	35.5	30.8	25.8	20.8	15.8	-
	62	33.3	2.5	33.3	33.3	31.9	26.9	21.9	16.9	31.0	2.8	31.0	31.0	30.1	25.1	20.0	15.0
	57	34.0	2.3	34.0	34.0	33.7	28.6	23.6	18.6	32.0	2.6	32.0	32.0	31.7	26.7	21.7	16.6
1600	77	66.1	3.9	29.2	24.8	18.0	-	-	-	62.6	4.1	31.5	24.3	17.4	-	-	-
	72	60.2	3.7	41.7	34.9	28.0	21.1	-	-	56.7	3.9	41.2	34.2	27.2	20.2	-	-
	67	54.3	3.5	54.3	44.9	38.0	31.1	24.3	-	50.8	3.8	50.8	44.0	37.0	30.0	23.1	-
	62	48.4	3.6	48.4	48.4	49.4	42.5	35.6	28.7	46.5	3.9	46.5	46.5	46.5	39.5	32.6	25.6
	57	53.5	3.6	53.5	53.5	48.8	41.9	35.0	32.8	50.5	3.9	50.5	50.5	46.0	39.0	32.1	27.4
				95°F						105°F							
1050	77	39.9	2.7	24.0	17.8	12.7	-	-	-	36.8	3.1	23.8	16.4	11.6	-	-	-
	72	36.6	2.8	28.7	23.7	18.6	13.6	-	-	33.5	3.1	27.0	22.3	17.5	12.8	-	-
	67	33.4	2.8	33.4	29.6	24.5	19.5	14.5	-	30.1	3.1	30.1	28.1	23.4	18.7	14.0	-
	62	28.8	3.1	28.8	28.8	28.2	23.2	18.1	13.1	26.6	3.4	26.6	26.6	26.1	21.3	16.6	11.9
	57	30.1	2.8	30.1	30.1	29.7	24.7	19.7	14.6	27.9	3.2	27.9	27.9	27.5	22.8	18.1	13.4
1600	77	59.0	4.2	33.8	23.9	16.8	-	-	-	53.4	4.6	34.7	22.5	15.2	-	-	-
	72	53.2	4.2	40.6	33.5	26.4	19.3	-	-	48.4	4.6	39.1	31.9	24.7	17.6	-	-
	67	47.4	4.2	47.4	43.1	36.0	29.0	21.9	-	43.5	4.6	43.5	41.3	34.3	27.1	20.0	-
	62	44.7	4.2	44.7	44.7	43.7	36.6	29.5	22.4	42.1	4.5	42.1	42.1	40.3	33.2	26.0	18.8
	57	47.5	4.2	47.5	47.5	43.2	36.2	29.1	22.0	44.3	4.5	44.3	44.3	40.1	33.0	25.8	18.7
				115°F													
1050	77	33.8	3.4	23.6	15.0	10.5	-	-	-								
	72	30.4	3.4	25.3	20.8	16.4	12.0	-	-								
	67	26.9	3.5	26.9	26.7	22.3	17.9	13.5	-								
	62	24.4	3.7	24.4	24.4	23.9	19.5	15.1	10.7								
	57	25.7	3.5	25.7	25.7	25.3	20.9	16.5	12.1								
1600	77	47.8	4.9	35.5	21.1	13.6	-	-	-								
	72	43.7	4.9	37.5	30.3	23.1	15.8	-	-								
	67	39.5	5.0	39.5	39.5	32.5	25.3	18.1	-								
	62	39.6	4.9	39.6	39.6	37.0	29.7	22.5	15.3								
	57	41.2	4.9	41.2	41.2	37.0	29.8	22.6	15.4								

1. These capacities are Net Capacities.
2. These ratings include the compressor, condenser fan and supply air blower motors.

BHX060 (5.0 Ton)

Air on Evaporator Coil		Temperature of Air on Condenser Coil																	
		Net Capacity ¹ (MBh)	Total Input (kW) ²	Sensible Capacity (MBh)						Net Capacity ¹ (MBh)	Total Input (kW) ²	Sensible Capacity (MBh)							
				Return Dry Bulb (°F)								Return Dry Bulb (°F)							
CFM	WB (°F)			90	85	80	75	70	65			90	85	80	75	70	65		
		75°F									85°F								
1200	77	55.4	2.6	27.9	22.7	17.5	-	-	-	52.0	3.0	26.9	21.7	16.4	-	-	-		
	72	50.6	2.7	34.5	29.3	24.1	18.9	-	-	47.3	3.0	33.4	28.1	22.9	17.6	-	-		
	67	45.8	2.7	41.0	35.8	30.7	25.5	20.3	-	42.6	3.0	39.8	34.6	29.3	24.1	18.8	-		
	62	40.8	2.6	40.8	40.8	37.1	31.9	26.8	21.6	38.3	3.0	38.3	38.3	35.9	30.7	25.4	20.2		
	57	40.1	2.6	40.1	40.1	39.4	34.2	29.1	23.9	38.0	3.1	38.0	38.0	37.2	32.0	26.7	21.5		
1700	77	77.6	4.5	37.0	30.4	23.7	-	-	-	72.6	4.9	36.1	29.4	22.6	-	-	-		
	72	71.5	4.4	46.1	39.5	32.9	26.2	-	-	66.9	4.8	45.0	38.3	31.5	24.8	-	-		
	67	65.4	4.2	55.3	48.6	42.0	35.4	28.7	-	61.2	4.7	54.0	47.2	40.5	33.7	27.0	-		
	62	59.3	4.1	59.3	59.3	53.5	46.8	40.2	33.6	55.6	4.5	55.6	55.6	51.2	44.4	37.7	30.9		
	57	57.6	4.1	57.6	57.6	56.3	49.7	43.1	40.3	54.6	4.6	54.6	54.6	53.3	46.5	39.8	34.9		
		95°F									105°F								
1200	77	48.5	3.5	25.9	20.6	15.3	-	-	-	44.5	3.9	23.4	18.6	14.0	-	-	-		
	72	44.0	3.4	32.2	26.9	21.6	16.4	-	-	40.2	3.9	29.4	24.8	20.2	15.6	-	-		
	67	39.4	3.4	38.6	33.3	28.0	22.7	17.4	-	35.8	3.9	35.4	31.0	26.4	21.8	17.2	-		
	62	35.8	3.4	35.8	35.8	34.7	29.4	24.1	18.8	33.0	3.8	33.0	33.0	32.5	27.9	23.3	18.7		
	57	35.8	3.5	35.8	35.8	35.0	29.7	24.4	19.1	32.9	4.0	32.9	32.9	32.0	27.4	22.8	18.2		
1700	77	67.5	5.3	35.2	28.4	21.5	-	-	-	62.6	6.0	33.7	26.1	19.2	-	-	-		
	72	62.3	5.2	44.0	37.1	30.2	23.4	-	-	57.6	5.8	42.1	35.2	28.3	21.5	-	-		
	67	57.1	5.1	52.7	45.8	39.0	32.1	25.2	-	52.7	5.7	50.5	44.3	37.4	30.6	23.7	-		
	62	51.9	5.0	51.9	51.9	48.9	42.0	35.2	28.3	48.3	5.6	48.3	48.3	46.5	39.7	32.8	25.9		
	57	51.6	5.1	51.6	51.6	50.2	43.4	36.5	29.6	48.1	5.7	48.1	48.1	46.8	39.9	33.0	26.1		
		115°F																	
1200	77	40.5	4.4	21.0	16.6	12.7	-	-	-										
	72	36.3	4.4	26.6	22.7	18.8	14.9	-	-										
	67	32.2	4.3	32.2	28.8	24.9	21.0	17.1	-										
	62	30.2	4.3	30.2	30.2	30.2	26.3	22.4	18.5										
	57	30.0	4.6	30.0	30.0	29.1	25.2	21.3	17.4										
1700	77	57.7	6.7	32.1	23.8	17.0	-	-	-										
	72	53.0	6.5	40.2	33.3	26.4	19.5	-	-										
	67	48.3	6.2	48.3	42.8	35.9	29.0	22.1	-										
	62	44.6	6.1	44.6	44.6	44.2	37.3	30.4	23.5										
	57	44.6	6.3	44.6	44.6	43.3	36.4	29.5	22.6										

1. These capacities are Net Capacities.
2. These ratings include the compressor, condenser fan and supply air blower motors.

BHX024-060 (5.0 Ton)

Size (Tons)	Air Over Evaporator Coil		Capacity ¹ & kW ²	Outdoor Temperature (°F @ 72% RH)							
	CFM	DB (°F)		-10	0	10	20	30	40	50	60
024 (2.0)	650	55	MBH	5.52	6.55	7.81	9.35	11.24	13.55	16.38	19.85
			KW	0.89	0.90	0.91	0.92	0.93	0.94	0.96	0.97
		70	MBH	4.58	5.61	6.87	8.41	10.30	12.61	15.44	18.91
			KW	1.07	1.08	1.09	1.10	1.11	1.13	1.14	1.15
		80	MBH	3.55	4.58	5.84	7.38	9.27	11.58	14.41	17.88
			KW	1.22	1.23	1.24	1.25	1.26	1.27	1.29	1.30
	800	55	MBH	11.33	12.80	14.53	16.54	18.91	21.67	24.91	28.71
			KW	1.03	1.07	1.13	1.19	1.25	1.31	1.37	1.43
		70	MBH	8.60	10.07	11.79	13.81	16.17	18.94	22.18	25.97
			KW	1.25	1.28	1.34	1.40	1.47	1.53	1.59	1.65
		80	MBH	7.49	8.96	10.68	12.70	15.06	17.83	21.07	24.87
			KW	1.44	1.48	1.54	1.60	1.66	1.72	1.78	1.84
036 (3.0)	900	55	MBH	10.90	12.40	14.14	16.14	18.46	21.15	24.25	27.84
			KW	1.44	1.48	1.53	1.57	1.62	1.67	1.72	1.77
		70	MBH	9.57	11.07	12.80	14.81	17.13	19.81	22.92	26.51
			KW	1.73	1.77	1.82	1.86	1.91	1.96	2.01	2.06
		80	MBH	8.77	10.27	12.01	14.01	16.33	19.01	22.12	25.71
			KW	2.05	2.10	2.14	2.19	2.23	2.28	2.33	2.38
	1100	55	MBH	13.92	16.10	18.68	21.75	25.38	29.69	34.80	40.85
			KW	1.68	1.77	1.86	1.96	2.06	2.16	2.27	2.39
		70	MBH	11.75	13.93	16.51	19.58	23.21	27.52	32.63	38.68
			KW	2.16	2.25	2.34	2.44	2.54	2.64	2.75	2.87
		80	MBH	7.25	9.43	12.02	15.08	18.72	23.02	28.13	34.19
			KW	2.08	2.17	2.27	2.36	2.46	2.57	2.68	2.79
048 (4.0)	1200	55	MBH	13.84	15.99	18.53	21.51	25.01	29.13	33.96	39.65
			KW	1.39	1.56	1.74	1.91	2.08	2.26	2.43	2.60
		70	MBH	12.34	14.50	17.04	20.02	23.52	27.63	32.47	38.15
			KW	1.88	2.06	2.23	2.40	2.58	2.75	2.92	3.09
		80	MBH	11.41	13.57	16.11	19.09	22.59	26.71	31.54	37.22
			KW	2.36	2.53	2.71	2.88	3.05	3.23	3.40	3.57
	1600	55	MBH	15.52	18.56	22.22	26.61	31.88	38.22	45.83	54.96
			KW	1.84	2.05	2.27	2.51	2.77	3.06	3.37	3.70
		70	MBH	15.13	18.17	21.83	26.22	31.49	37.83	45.44	54.57
			KW	2.43	2.63	2.86	3.10	3.36	3.64	3.95	4.28
		80	MBH	14.45	17.49	21.15	25.54	30.81	37.15	44.76	53.89
			KW	3.09	3.30	3.52	3.76	4.02	4.30	4.61	4.95
060 (5.0)	1200	55	MBH	13.78	16.37	19.51	23.30	27.90	33.46	40.20	48.36
			KW	1.59	1.77	1.97	2.18	2.41	2.65	2.91	3.20
		70	MBH	12.28	14.87	18.00	21.80	26.39	31.96	38.69	46.85
			KW	2.32	2.50	2.70	2.91	3.14	3.38	3.64	3.93
		80	MBH	11.43	14.02	17.16	20.95	25.55	31.11	37.85	46.01
			KW	2.98	3.16	3.35	3.56	3.79	4.03	4.30	4.58
	1700	55	MBH	22.93	26.78	31.33	36.69	43.03	50.51	59.34	69.77
			KW	1.37	1.70	2.07	2.49	2.97	3.51	4.12	4.81
		70	MBH	21.30	25.15	29.70	35.06	41.40	48.88	57.71	68.14
			KW	2.49	2.82	3.19	3.61	4.09	4.63	5.24	5.93
		80	MBH	19.88	23.73	28.27	33.64	39.98	47.46	56.29	66.72
			KW	3.43	3.76	4.13	4.55	5.03	5.57	6.18	6.87

1. These Capacities are net capacities - the indoor motor heat has been added.
2. These power inputs are total power inputs - the indoor motor watts have been added.

Airflow Performance

Side Duct Application

DNX/DNY/BHX024-060

Size (Tons)	Model	Mode	Thermostat Input	Speed Tap	CFM	External Static Pressure (Inch Water Gauge)										
						0.2	0.3	0.4	0.5	0.6	0.7	0.8	0.9	1.0		
						Watts	Watts	Watts	Watts	Watts	Watts	Watts	Watts	Watts	Watts	
024 (2.0)	DNX DNY	Cool	Low	Y1	COOL-A	600	100	122	145	169	194	221	249	279	310	
				Y1	COOL-B	450	65	81	100	122	147	176	208	243	281	
				Y1	COOL-C	530	81	100	121	145	170	197	226	258	291	
				Y1	COOL-D	680	127	151	176	202	228	256	284	313	342	
			High	Y1+Y2	COOL-A	800	177	204	232	261	290	320	350	382	414	
				Y1+Y2	COOL-B	600	100	122	145	169	194	221	249	279	310	
				Y1+Y2	COOL-C	700	134	159	184	211	238	265	293	323	352	
				Y1+Y2	COOL-D	900	229	258	288	319	351	385	420	457	494	
		Heat	N036	W1	HEAT-A	670	123	147	172	197	224	251	-	-	-	
				W1	HEAT-B	730	146	172	198	225	252	280	-	-	-	
				W1	HEAT-C	790	173	199	227	255	284	314	-	-	-	
				W1	HEAT-D	850	202	230	259	289	319	351	-	-	-	
			N056	W1	HEAT-A	940	253	281	312	344	378	-	-	-	-	
				W1	HEAT-B	975	274	303	334	368	403	-	-	-	-	
				W1	HEAT-C	1000	290	319	351	385	422	-	-	-	-	
				W1	HEAT-D	1050	324	353	386	422	461	-	-	-	-	
			D056	W1	HEAT-A	670	123	147	172	197	224	-	-	-	-	
				W1	HEAT-B	690	130	155	180	206	233	-	-	-	-	
				W1	HEAT-C	710	138	163	189	215	242	-	-	-	-	
				W1	HEAT-D	750	155	181	207	235	262	-	-	-	-	
				W1+W2	HEAT-A	940	253	281	312	344	378	-	-	-	-	
				W1+W2	HEAT-B	970	271	300	331	364	400	-	-	-	-	
				W1+W2	HEAT-C	1000	290	319	351	385	422	-	-	-	-	
				W1+W2	HEAT-D	1050	324	353	386	422	461	-	-	-	-	
	BHX	Cool	Low	Y1	COOL-A	600	58	74	91	108	126	143	161	179	197	
				Y1	COOL-B	450	39	53	68	84	100	117	134	152	170	
				Y1	COOL-C	525	47	63	79	95	112	129	146	164	182	
				Y1	COOL-D	675	71	89	106	124	143	161	179	198	217	
			High	Y1+Y2	COOL-A	800	99	118	137	157	177	197	217	238	259	
				Y1+Y2	COOL-B	600	58	74	91	108	126	143	161	179	197	
				Y1+Y2	COOL-C	700	76	94	112	130	149	167	186	205	224	
				Y1+Y2	COOL-D	900	127	146	167	188	209	231	254	277	301	
			Heat	Heat Pump	Y1	COOL-A	800	99	118	137	157	177	197	217	238	259
					Y1	COOL-B	600	58	74	91	108	126	143	161	179	197
					Y1	COOL-C	700	76	94	112	130	149	167	186	205	224
					Y1	COOL-D	900	127	146	167	188	209	231	254	277	301
		Heat Pump + Aux. Heat		Y1+W1	COOL-A; HEAT-A	800	99	118	137	157	-	-	-	-	-	
				Y1+W1	COOL-A; HEAT-B	800	99	118	137	157	-	-	-	-	-	
				Y1+W1	COOL-A; HEAT-C	880	121	140	160	181	-	-	-	-	-	
				Y1+W1	COOL-A; HEAT-D	800	99	118	137	157	-	-	-	-	-	
				Y1+W1	COOL-B; HEAT-A	800	99	118	137	157	-	-	-	-	-	
				Y1+W1	COOL-B; HEAT-B	720	80	98	117	135	-	-	-	-	-	
				Y1+W1	COOL-B; HEAT-C	880	121	140	160	181	-	-	-	-	-	
				Y1+W1	COOL-B; HEAT-D	800	99	118	137	157	-	-	-	-	-	
			Y1+W1	COOL-C; HEAT-A	800	99	118	137	157	-	-	-	-	-		
			Y1+W1	COOL-C; HEAT-B	720	80	98	117	135	-	-	-	-	-		
			Y1+W1	COOL-C; HEAT-C	880	121	140	160	181	-	-	-	-	-		
			Y1+W1	COOL-C; HEAT-D	800	99	118	137	157	-	-	-	-	-		
Y1+W1	COOL-D; HEAT-A		900	127	146	167	188	-	-	-	-	-				
Y1+W1	COOL-D; HEAT-B		900	127	146	167	188	-	-	-	-	-				
Y1+W1	COOL-D; HEAT-C		900	127	146	167	188	-	-	-	-	-				
Y1+W1	COOL-D; HEAT-D		900	127	146	167	188	-	-	-	-	-				

DNX/DNY/BHX024-060 (Continued)

Size (Tons)	Model	Mode	Thermostat Input	Speed Tap	CFM	External Static Pressure (Inch Water Gauge)										
						0.2	0.3	0.4	0.5	0.6	0.7	0.8	0.9	1.0		
						Watts	Watts	Watts	Watts	Watts	Watts	Watts	Watts	Watts		
036 (3.0)	DNY	Cool	Low	Y1	COOL-A	800	200	239	278	317	356	394	432	470	507	
				Y1	COOL-B	700	169	203	237	270	303	336	367	398	429	
				Y1	COOL-C	770	189	227	265	302	339	376	412	448	483	
				Y1	COOL-D	900	243	286	329	373	417	461	505	549	594	
			High	Y1+Y2	COOL-A	1200	439	489	541	595	652	710	771	835	900	
				Y1+Y2	COOL-B	1050	328	375	424	474	524	576	629	684	738	
				Y1+Y2	COOL-C	1150	399	448	499	552	607	664	722	783	844	
				Y1+Y2	COOL-D	1350	576	626	680	737	798	863	932	1005	-	
		Heat	N036	W1	HEAT-A	670	162	194	227	258	289	320	-	-	-	-
				W1	HEAT-B	730	177	213	248	283	318	352	-	-	-	
				W1	HEAT-C	790	196	235	274	312	350	388	-	-	-	
				W1	HEAT-D	850	220	261	303	344	385	426	-	-	-	
			N056	W1	HEAT-A	1050	328	375	424	474	524	-	-	-	-	
				W1	HEAT-B	1135	388	437	488	540	594	-	-	-	-	
				W1	HEAT-C	1220	456	506	558	613	670	-	-	-	-	
				W1	HEAT-D	1300	528	578	631	687	747	-	-	-	-	
			D056	W1	HEAT-A	680	164	197	230	262	294	-	-	-	-	
				W1	HEAT-B	735	178	215	250	286	321	-	-	-	-	
				W1	HEAT-C	790	196	235	274	312	350	-	-	-	-	
				W1	HEAT-D	840	216	257	297	338	379	-	-	-	-	
				W1+W2	HEAT-A	1050	328	375	424	474	524	-	-	-	-	
				W1+W2	HEAT-B	1140	392	441	491	544	598	-	-	-	-	
				W1+W2	HEAT-C	1220	456	506	558	613	670	-	-	-	-	
				W1+W2	HEAT-D	1300	528	578	631	687	747	-	-	-	-	
			N072	W1	HEAT-A	1200	439	489	541	595	-	-	-	-	-	
				W1	HEAT-B	1300	528	578	631	687	-	-	-	-	-	
				W1	HEAT-C	1400	628	677	731	789	-	-	-	-	-	
				W1	HEAT-D	1475	710	759	812	871	-	-	-	-	-	
			D072	W1	HEAT-A	790	196	235	274	312	-	-	-	-	-	
				W1	HEAT-B	855	222	264	305	347	-	-	-	-	-	
				W1	HEAT-C	920	252	296	341	385	-	-	-	-	-	
				W1	HEAT-D	975	282	328	374	421	-	-	-	-	-	
				W1+W2	HEAT-A	1200	439	489	541	595	-	-	-	-	-	
				W1+W2	HEAT-B	1300	528	578	631	687	-	-	-	-	-	
				W1+W2	HEAT-C	1400	628	677	731	789	-	-	-	-	-	
				W1+W2	HEAT-D	1480	716	764	818	877	-	-	-	-	-	
		DNX	Cool	Low	Y1	COOL-A	900	198	233	272	313	358	406	458	512	569
					Y1	COOL-B	760	166	190	222	262	310	366	431	503	584
					Y1	COOL-C	830	180	210	245	286	332	384	441	503	571
					Y1	COOL-D	970	221	260	302	344	388	434	481	530	579
				High	Y1+Y2	COOL-A	1250	361	408	454	501	548	594	640	687	733
					Y1+Y2	COOL-B	1050	253	296	340	384	428	472	516	561	605
					Y1+Y2	COOL-C	1150	302	348	394	439	484	528	571	615	657
					Y1+Y2	COOL-D	1350	429	475	522	570	620	671	723	777	831
			Heat	N065	W1	HEAT-A	1200	330	377	423	469	515	560	-	-	-
					W1	HEAT-B	1300	394	440	487	535	583	631	-	-	-
					W1	HEAT-C	1400	467	511	558	607	659	713	-	-	-
					W1	HEAT-D	1500	550	590	635	686	743	804	-	-	-
				N090	W1	HEAT-A	1150	302	348	394	439	484	528	-	-	-
					W1	HEAT-B	1225	345	392	439	485	531	577	-	-	-
					W1	HEAT-C	1275	377	424	471	518	565	612	-	-	-
					W1	HEAT-D	1350	429	475	522	570	620	671	-	-	-
D090	W1			HEAT-A	740	163	185	216	255	304	362	-	-	-		
	W1			HEAT-B	785	170	196	230	270	317	372	-	-	-		
	W1			HEAT-C	825	178	208	243	284	330	382	-	-	-		
	W1			HEAT-D	870	189	223	260	301	347	396	-	-	-		
	W1+W2			HEAT-A	1150	302	348	394	439	484	528	-	-	-		
	W1+W2			HEAT-B	1220	342	389	436	482	528	573	-	-	-		
	W1+W2			HEAT-C	1280	380	427	474	521	568	616	-	-	-		
	W1+W2			HEAT-D	1350	429	475	522	570	620	671	-	-	-		

DNX/DNY/BHX024-060 (Continued)

Size (Tons)	Model	Mode	Thermostat Input	Speed Tap	CFM	External Static Pressure (Inch Water Gauge)											
						0.2	0.3	0.4	0.5	0.6	0.7	0.8	0.9	1.0			
						Watts	Watts	Watts	Watts	Watts	Watts	Watts	Watts	Watts			
036 (3.0)	BHX	Cool	Low	Y1	COOL-A	900	140	165	191	217	245	273	303	333	364		
				Y1	COOL-B	750	98	122	146	171	196	222	248	275	302		
				Y1	COOL-C	825	118	142	167	192	219	246	273	302	331		
				Y1	COOL-D	975	163	190	217	246	275	305	336	368	400		
			High	Y1+Y2	COOL-A	1200	245	279	314	349	385	421	457	494	531		
				Y1+Y2	COOL-B	1000	171	199	227	256	285	316	347	380	413		
				Y1+Y2	COOL-C	1100	206	237	268	300	332	365	399	434	468		
				Y1+Y2	COOL-D	1300	286	326	366	405	444	483	522	562	600		
		Heat	Heat Pump	Y1	COOL-A	1200	245	279	314	349	385	421	457	494	531		
				Y1	COOL-B	1000	171	199	227	256	285	316	347	380	413		
				Y1	COOL-C	1100	206	237	268	300	332	365	399	434	468		
				Y1	COOL-D	1300	286	326	366	405	444	483	522	562	600		
			Heat Pump + Aux. Heat	Y1+W1	COOL-A; HEAT-A	1200	245	279	314	349	-	-	-	-	-		
				Y1+W1	COOL-A; HEAT-B	1200	245	279	314	349	-	-	-	-	-		
				Y1+W1	COOL-A; HEAT-C	1320	295	336	376	417	-	-	-	-	-		
				Y1+W1	COOL-A; HEAT-D	1200	245	279	314	349	-	-	-	-	-		
				Y1+W1	COOL-B; HEAT-A	1200	245	279	314	349	-	-	-	-	-		
				Y1+W1	COOL-B; HEAT-B	1080	199	229	259	290	-	-	-	-	-		
				Y1+W1	COOL-B; HEAT-C	1320	295	336	376	417	-	-	-	-	-		
				Y1+W1	COOL-B; HEAT-D	1200	245	279	314	349	-	-	-	-	-		
		Y1+W1		COOL-C; HEAT-A	1200	245	279	314	349	-	-	-	-	-			
		Y1+W1		COOL-C; HEAT-B	1100	206	237	268	300	-	-	-	-	-			
		Y1+W1		COOL-C; HEAT-C	1320	295	336	376	417	-	-	-	-	-			
		Y1+W1		COOL-C; HEAT-D	1200	245	279	314	349	-	-	-	-	-			
		048 (4.0)	DNX DNY	Cool	Low	Y1	COOL-A	1030	237	280	323	367	411	455	499	543	588
						Y1	COOL-B	930	192	237	282	326	369	413	455	497	539
						Y1	COOL-C	1070	257	300	343	386	430	475	520	565	611
						Y1	COOL-D	1130	289	332	375	419	463	509	555	602	649
High	Y1+Y2				COOL-A	1550	586	640	696	752	810	869	929	991	1053		
	Y1+Y2				COOL-B	1400	466	513	561	611	663	715	770	826	882		
	Y1+Y2				COOL-C	1600	630	687	745	804	864	926	988	1052	1116		
	Y1+Y2				COOL-D	1700	723	787	851	916	982	1049	1116	1185	-		
Heat	N065			W1	HEAT-A	1200	330	373	416	461	507	554	-	-	-		
				W1	HEAT-B	1300	394	439	484	531	579	629	-	-	-		
				W1	HEAT-C	1400	466	513	561	611	663	715	-	-	-		
				W1	HEAT-D	1500	544	596	648	702	758	815	-	-	-		
	N090			W1	HEAT-A	1325	412	456	503	550	599	649	-	-	-		
				W1	HEAT-B	1400	466	513	561	611	663	715	-	-	-		
				W1	HEAT-C	1500	544	596	648	702	758	815	-	-	-		
				W1	HEAT-D	1600	630	687	745	804	864	926	-	-	-		
	D090			W1	HEAT-A	870	168	215	261	306	350	393	-	-	-		
				W1	HEAT-B	920	188	233	278	322	366	409	-	-	-		
				W1	HEAT-C	985	216	260	303	347	391	434	-	-	-		
				W1	HEAT-D	1050	247	290	333	376	420	464	-	-	-		
				W1+W2	HEAT-A	1330	415	460	506	554	603	653	-	-	-		
				W1+W2	HEAT-B	1400	466	513	561	611	663	715	-	-	-		
				W1+W2	HEAT-C	1500	544	596	648	702	758	815	-	-	-		
				W1+W2	HEAT-D	1600	630	687	745	804	864	926	-	-	-		
	N110			W1	HEAT-A	1450	504	553	604	656	-	-	-	-	-		
				W1	HEAT-B	1500	544	596	648	702	-	-	-	-	-		
				W1	HEAT-C	1600	630	687	745	804	-	-	-	-	-		
				W1	HEAT-D	1700	723	787	851	916	-	-	-	-	-		
D110	W1	HEAT-A	940	196	241	285	329	-	-	-	-	-					
	W1	HEAT-B	970	209	253	297	341	-	-	-	-	-					
	W1	HEAT-C	1050	247	290	333	376	-	-	-	-	-					
	W1	HEAT-D	1100	273	315	358	402	-	-	-	-	-					
	W1+W2	HEAT-A	1450	504	553	604	656	-	-	-	-	-					
	W1+W2	HEAT-B	1500	544	596	648	702	-	-	-	-	-					

DNX/DNY/BHX024-060 (Continued)

Size (Tons)	Model	Mode	Thermostat Input	Speed Tap	CFM	External Static Pressure (Inch Water Gauge)									
						0.2	0.3	0.4	0.5	0.6	0.7	0.8	0.9	1.0	
						Watts	Watts	Watts	Watts	Watts	Watts	Watts	Watts	Watts	
048 (4.0)	BHX	Cool	Low	Y1	COOL-A	1050	184	216	248	280	313	346	380	414	448
				Y1	COOL-B	918	138	166	194	224	254	286	318	351	385
				Y1	COOL-C	984	160	190	220	251	282	315	348	381	416
				Y1	COOL-D	1115	210	243	277	311	345	379	414	449	484
			High	Y1+Y2	COOL-A	1600	448	500	551	600	647	693	736	779	819
				Y1+Y2	COOL-B	1400	338	383	426	468	509	549	589	627	664
				Y1+Y2	COOL-C	1500	391	439	486	532	576	618	660	700	739
				Y1+Y2	COOL-D	1700	508	565	620	672	723	772	818	863	905
		Heat	Heat Pump	Y1	COOL-A	1600	448	500	551	600	647	693	736	779	819
				Y1	COOL-B	1400	338	383	426	468	509	549	589	627	664
				Y1	COOL-C	1500	391	439	486	532	576	618	660	700	739
				Y1	COOL-D	1700	508	565	620	672	723	772	818	863	905
			Heat Pump + Aux. Heat	Y1+W1	COOL-A; HEAT-A	1600	448	500	551	600	647	-	-	-	-
				Y1+W1	COOL-A; HEAT-B	1600	448	500	551	600	647	-	-	-	-
				Y1+W1	COOL-A; HEAT-C	1760	546	606	663	718	771	-	-	-	-
				Y1+W1	COOL-A; HEAT-D	1600	448	500	551	600	647	-	-	-	-
				Y1+W1	COOL-B; HEAT-A	1600	448	500	551	600	647	-	-	-	-
				Y1+W1	COOL-B; HEAT-B	1440	359	405	449	493	535	-	-	-	-
				Y1+W1	COOL-B; HEAT-C	1760	546	606	663	718	771	-	-	-	-
				Y1+W1	COOL-B; HEAT-D	1600	448	500	551	600	647	-	-	-	-
				Y1+W1	COOL-C; HEAT-A	1600	448	500	551	600	647	-	-	-	-
				Y1+W1	COOL-C; HEAT-B	1500	391	439	486	532	576	-	-	-	-
				Y1+W1	COOL-C; HEAT-C	1760	546	606	663	718	771	-	-	-	-
				Y1+W1	COOL-C; HEAT-D	1600	448	500	551	600	647	-	-	-	-
				Y1+W1	COOL-D; HEAT-A	1700	508	565	620	672	723	-	-	-	-
				Y1+W1	COOL-D; HEAT-B	1700	508	565	620	672	723	-	-	-	-
				Y1+W1	COOL-D; HEAT-C	1760	546	606	663	718	771	-	-	-	-
				Y1+W1	COOL-D; HEAT-D	1700	508	565	620	672	723	-	-	-	-
060 (5.0)	DNY	Cool	Low	Y1	COOL-A	1200	330	373	416	461	507	554	602	651	700
				Y1	COOL-B	1060	252	295	338	381	425	470	514	559	605
				Y1	COOL-C	1130	289	332	375	419	463	509	555	602	649
				Y1	COOL-D	1270	374	418	463	509	556	605	655	706	758
			High	Y1+Y2	COOL-A	1700	723	787	851	916	982	1049	1116	1185	1253
				Y1+Y2	COOL-B	1500	544	596	648	702	758	815	873	932	993
				Y1+Y2	COOL-C	1600	630	687	745	804	864	926	988	1052	1116
				Y1+Y2	COOL-D	1800	823	895	967	1039	1112	1185	1257	-	-
		Heat	N065	W1	HEAT-A	1200	330	373	416	461	507	554	-	-	-
				W1	HEAT-B	1300	394	439	484	531	579	629	-	-	-
				W1	HEAT-C	1400	466	513	561	611	663	715	-	-	-
				W1	HEAT-D	1500	544	596	648	702	758	815	-	-	-
			N090	W1	HEAT-A	1325	412	456	503	550	599	649	-	-	-
				W1	HEAT-B	1400	466	513	561	611	663	715	-	-	-
				W1	HEAT-C	1500	544	596	648	702	758	815	-	-	-
				W1	HEAT-D	1600	630	687	745	804	864	926	-	-	-
			D090	W1	HEAT-A	870	168	215	261	306	350	393	-	-	-
				W1	HEAT-B	920	188	233	278	322	366	409	-	-	-
				W1	HEAT-C	985	216	260	303	347	391	434	-	-	-
				W1	HEAT-D	1050	247	290	333	376	420	464	-	-	-
				W1+W2	HEAT-A	1330	415	460	506	554	603	653	-	-	-
				W1+W2	HEAT-B	1400	466	513	561	611	663	715	-	-	-
				W1+W2	HEAT-C	1500	544	596	648	702	758	815	-	-	-
				W1+W2	HEAT-D	1600	630	687	745	804	864	926	-	-	-
			N110	W1	HEAT-A	1450	504	553	604	656	709	763	-	-	-
				W1	HEAT-B	1500	544	596	648	702	758	815	-	-	-
				W1	HEAT-C	1600	630	687	745	804	864	926	-	-	-
				W1	HEAT-D	1700	723	787	851	916	982	1049	-	-	-
			D110	W1	HEAT-A	940	196	241	285	329	373	416	-	-	-
				W1	HEAT-B	985	216	260	303	347	391	434	-	-	-
				W1	HEAT-C	1035	239	282	326	369	413	457	-	-	-
				W1	HEAT-D	1100	273	315	358	402	446	491	-	-	-
				W1+W2	HEAT-A	1450	504	553	604	656	709	763	-	-	-
				W1+W2	HEAT-B	1500	544	596	648	702	758	815	-	-	-
				W1+W2	HEAT-C	1600	630	687	745	804	864	926	-	-	-
				W1+W2	HEAT-D	1700	723	787	851	916	982	1049	-	-	-

DNX/DNY/BHX024-060 (Continued)

Size (Tons)	Model	Mode	Thermostat Input	Speed Tap	CFM	External Static Pressure (Inch Water Gauge)									
						0.2	0.3	0.4	0.5	0.6	0.7	0.8	0.9	1.0	
						Watts	Watts	Watts	Watts	Watts	Watts	Watts	Watts	Watts	
060 (5.0)	BHX	Cool	Low	Y1	COOL-A	1200	138	176	211	244	275	303	329	352	374
				Y1	COOL-B	1130	61	98	133	163	190	213	232	247	260
				Y1	COOL-C	1270	208	246	283	318	353	386	418	448	478
			Y1	COOL-D	1340	272	310	348	386	423	460	497	533	570	
			High	Y1+Y2	COOL-A	1700	487	531	575	621	668	716	765	816	867
				Y1+Y2	COOL-B	1600	446	487	530	574	619	666	714	763	814
		Y1+Y2		COOL-C	1800	514	560	607	654	701	749	798	847	897	
		Heat	Heat Pump	Y1	COOL-A	1700	487	531	575	621	668	716	765	816	867
				Y1	COOL-B	1600	446	487	530	574	619	666	714	763	814
				Y1	COOL-C	1800	514	560	607	654	701	749	798	847	897
				Y1	COOL-D	1900	526	576	624	672	720	766	813	859	-
			Heat Pump + Aux. Heat	Y1+W1	COOL-A; HEAT-A	1900	526	576	624	672	720	-	-	-	-
				Y1+W1	COOL-A; HEAT-B	1975	526	578	628	677	723	-	-	-	-
				Y1+W1	COOL-A; HEAT-C	2150	495	554	607	656	699	-	-	-	-
				Y1+W1	COOL-A; HEAT-D	2070	515	570	622	671	716	-	-	-	-
				Y1+W1	COOL-B; HEAT-A	1900	526	576	624	672	720	-	-	-	-
				Y1+W1	COOL-B; HEAT-B	1975	526	578	628	677	723	-	-	-	-
				Y1+W1	COOL-B; HEAT-C	2150	495	554	607	656	699	-	-	-	-
				Y1+W1	COOL-B; HEAT-D	2070	515	570	622	671	716	-	-	-	-
				Y1+W1	COOL-C; HEAT-A	1900	526	576	624	672	720	-	-	-	-
				Y1+W1	COOL-C; HEAT-B	1975	526	578	628	677	723	-	-	-	-
				Y1+W1	COOL-C; HEAT-C	2150	495	554	607	656	699	-	-	-	-
				Y1+W1	COOL-C; HEAT-D	2070	515	570	622	671	716	-	-	-	-
				Y1+W1	COOL-D; HEAT-A	1900	526	576	624	672	720	-	-	-	-
Y1+W1	COOL-D; HEAT-B			1975	526	578	628	677	723	-	-	-	-		
Y1+W1	COOL-D; HEAT-C	2150	495	554	607	656	699	-	-	-	-				
Y1+W1	COOL-D; HEAT-D	2070	515	570	622	671	716	-	-	-	-				

DNZ/BHZ/DEZ024-060

Size (Tons)	Model	Unit Speed	External Static Pressure (Inch Water Gauge)														
			0.2			0.4			0.6			0.8			1.0		
			SCFM	W	RPM	SCFM	W	RPM	SCFM	W	RPM	SCFM	W	RPM	SCFM	W	RPM
024 (2.0)	DNZ	Low (1)	719	115	752	617	130	858	-	-	-	-	-	-	-	-	-
		Low/Medium (2)	781	137	789	691	155	891	-	-	-	-	-	-	-	-	-
		Medium (3)	902	187	858	824	207	949	734	223	1037	622	230	1116	-	-	-
		Medium/High (4)	-	-	-	937	258	998	845	270	1075	722	271	1146	-	-	-
		High (5)	-	-	-	-	-	-	933	316	1104	796	307	1162	-	-	-
	BHZ	Low (1)	721	82	600	611	97	705	-	-	-	-	-	-	-	-	-
		Low/Medium (2)	769	93	628	694	112	730	610	126	832	-	-	-	-	-	-
		Medium (3)	882	131	704	812	147	797	736	162	889	651	177	979	-	-	-
		Medium/High (4)	971	171	773	916	188	857	851	205	939	775	219	1019	681	230	1097
		High (5)	-	-	-	-	-	-	957	249	982	887	261	1052	788	266	1120
	DEZ	Low (1)	726	87	632	629	99	739	-	-	-	-	-	-	-	-	-
		Low/Medium (2)	768	97	651	679	110	754	-	-	-	-	-	-	-	-	-
		Medium (3)	883	131	704	812	147	797	736	162	889	651	177	979	-	-	-
		Medium/High (4)	990	170	755	934	187	839	868	202	920	791	216	1000	696	227	1078
		High (5)	-	-	-	-	-	-	985	245	952	913	257	1022	813	261	1090
030 (2.5)	DNZ	Low (1)	827	163	825	759	187	919	-	-	-	-	-	-	-	-	-
		Low/Medium (2)	988	251	914	916	269	992	831	282	1067	-	-	-	-	-	-
		Medium (3)	1113	322	984	1035	333	1047	941	337	1108	818	329	1162	-	-	-
		Medium/High (4)	1233	394	1050	1145	394	1099	1040	388	1145	901	367	1184	-	-	-
		High (5)	-	-	-	-	-	-	1078	425	1164	867	353	1173	-	-	-
	BHZ	Low (1)	828	110	673	759	125	771	-	-	-	-	-	-	-	-	-
		Low/Medium (2)	991	168	754	934	187	839	868	205	922	783	221	1003	-	-	-
		Medium (3)	1091	214	807	1041	234	883	983	253	958	910	269	1033	785	273	1106
		Medium/High (4)	1189	269	861	1144	288	927	1091	305	994	1027	318	1061	912	316	1132
		High (5)	-	-	-	1235	347	970	1186	360	1028	1125	368	1086	1007	352	1147
	DEZ	Low (1)	828	110	673	759	125	771	-	-	-	-	-	-	-	-	-
		Low/Medium (2)	953	153	735	894	172	823	824	189	909	-	-	-	-	-	-
		Medium (3)	1091	214	807	1041	234	883	983	253	958	910	269	1033	785	273	1106
		Medium/High (4)	1189	269	861	1144	288	927	1091	305	994	1027	318	1061	912	316	1132
		High (5)	-	-	-	1235	347	970	1186	360	1028	1125	368	1086	1007	352	1147

Bottom Duct Application

DNX/DNY/BHX024-060

Size (Tons)	Model	Mode	Thermostat Input	Speed Tap	CFM	External Static Pressure (Inch Water Gauge)									
						0.2	0.3	0.4	0.5	0.6	0.7	0.8	0.9	1.0	
						Watts	Watts	Watts	Watts	Watts	Watts	Watts	Watts	Watts	
024 (2.0)	DNX DNY	Cool	Low	Y1	COOL-A	600	100	122	145	169	194	221	249	279	310
				Y1	COOL-B	450	65	81	100	122	147	176	208	243	281
				Y1	COOL-C	530	81	100	121	145	170	197	226	258	291
				Y1	COOL-D	680	127	151	176	202	228	256	284	313	342
			High	Y1+Y2	COOL-A	800	177	204	232	261	290	320	350	382	414
				Y1+Y2	COOL-B	600	100	122	145	169	194	221	249	279	310
				Y1+Y2	COOL-C	700	134	159	184	211	238	265	293	323	352
				Y1+Y2	COOL-D	900	229	258	288	319	351	385	420	457	494
		Heat	N036	W1	HEAT-A	670	123	147	172	197	224	251	-	-	-
				W1	HEAT-B	730	146	172	198	225	252	280	-	-	-
				W1	HEAT-C	790	173	199	227	255	284	314	-	-	-
				W1	HEAT-D	850	202	230	259	289	319	351	-	-	-
			N056	W1	HEAT-A	940	253	281	312	344	378	-	-	-	-
				W1	HEAT-B	975	274	303	334	368	403	-	-	-	-
				W1	HEAT-C	1000	290	319	351	385	422	-	-	-	-
				W1	HEAT-D	1050	324	353	386	422	461	-	-	-	-
		D056	W1	HEAT-A	670	123	147	172	197	224	-	-	-	-	
			W1	HEAT-B	690	130	155	180	206	233	-	-	-	-	
			W1	HEAT-C	710	138	163	189	215	242	-	-	-	-	
			W1	HEAT-D	750	155	181	207	235	262	-	-	-	-	
	W1+W2		HEAT-A	940	253	281	312	344	378	-	-	-	-		
	W1+W2		HEAT-B	970	271	300	331	364	400	-	-	-	-		
	W1+W2		HEAT-C	1000	290	319	351	385	422	-	-	-	-		
	W1+W2		HEAT-D	1050	324	353	386	422	461	-	-	-	-		
	BHX	Cool	Low	Y1	COOL-A	600	58	74	91	108	126	143	161	179	197
				Y1	COOL-B	450	39	53	68	84	100	117	134	152	170
				Y1	COOL-C	525	47	63	79	95	112	129	146	164	182
				Y1	COOL-D	675	71	89	106	124	143	161	179	198	217
			High	Y1+Y2	COOL-A	800	99	118	137	157	177	197	217	238	259
				Y1+Y2	COOL-B	600	58	74	91	108	126	143	161	179	197
				Y1+Y2	COOL-C	700	76	94	112	130	149	167	186	205	224
				Y1+Y2	COOL-D	900	127	146	167	188	209	231	254	277	301
		Heat Pump	Y1	COOL-A	800	99	118	137	157	177	197	217	238	259	
			Y1	COOL-B	600	58	74	91	108	126	143	161	179	197	
			Y1	COOL-C	700	76	94	112	130	149	167	186	205	224	
			Y1	COOL-D	900	127	146	167	188	209	231	254	277	301	
		Heat	Heat Pump + Aux. Heat	Y1+W1	COOL-A; HEAT-A	800	99	118	137	157	-	-	-	-	-
				Y1+W1	COOL-A; HEAT-B	800	99	118	137	157	-	-	-	-	-
				Y1+W1	COOL-A; HEAT-C	880	121	140	160	181	-	-	-	-	-
				Y1+W1	COOL-A; HEAT-D	800	99	118	137	157	-	-	-	-	-
Y1+W1				COOL-B; HEAT-A	800	99	118	137	157	-	-	-	-	-	
Y1+W1				COOL-B; HEAT-B	720	80	98	117	135	-	-	-	-	-	
Y1+W1				COOL-B; HEAT-C	880	121	140	160	181	-	-	-	-	-	
Y1+W1				COOL-B; HEAT-D	800	99	118	137	157	-	-	-	-	-	
Y1+W1	COOL-C; HEAT-A			800	99	118	137	157	-	-	-	-	-		
Y1+W1	COOL-C; HEAT-B			720	80	98	117	135	-	-	-	-	-		
Y1+W1	COOL-C; HEAT-C			880	121	140	160	181	-	-	-	-	-		
Y1+W1	COOL-C; HEAT-D			800	99	118	137	157	-	-	-	-	-		
Y1+W1	COOL-D; HEAT-A	900	127	146	167	188	-	-	-	-	-				
Y1+W1	COOL-D; HEAT-B	900	127	146	167	188	-	-	-	-	-				
Y1+W1	COOL-D; HEAT-C	900	127	146	167	188	-	-	-	-	-				
Y1+W1	COOL-D; HEAT-D	900	127	146	167	188	-	-	-	-	-				

DNX/DNY/BHX024-060 (Continued)

Size (Tons)	Model	Mode	Thermostat Input	Speed Tap	CFM	External Static Pressure (Inch Water Gauge)										
						0.2	0.3	0.4	0.5	0.6	0.7	0.8	0.9	1.0		
						Watts	Watts	Watts	Watts	Watts	Watts	Watts	Watts	Watts		
036 (3.0)	DNY	Cool	Low	Y1	COOL-A	800	200	239	278	317	356	394	432	470	507	
				Y1	COOL-B	700	169	203	237	270	303	336	367	398	429	
				Y1	COOL-C	770	189	227	265	302	339	376	412	448	483	
				Y1	COOL-D	900	243	286	329	373	417	461	505	549	594	
			High	Y1+Y2	COOL-A	1200	439	489	541	595	652	710	771	835	900	
				Y1+Y2	COOL-B	1050	328	375	424	474	524	576	629	684	738	
				Y1+Y2	COOL-C	1150	399	448	499	552	607	664	722	783	844	
				Y1+Y2	COOL-D	1350	576	626	680	737	798	863	932	1005	-	
		Heat	N036	W1	HEAT-A	670	162	194	227	258	289	320	-	-	-	-
				W1	HEAT-B	730	177	213	248	283	318	352	-	-	-	
				W1	HEAT-C	790	196	235	274	312	350	388	-	-	-	
				W1	HEAT-D	850	220	261	303	344	385	426	-	-	-	
			N056	W1	HEAT-A	1050	328	375	424	474	524	-	-	-	-	
				W1	HEAT-B	1135	388	437	488	540	594	-	-	-	-	
				W1	HEAT-C	1220	456	506	558	613	670	-	-	-	-	
				W1	HEAT-D	1300	528	578	631	687	747	-	-	-	-	
			D056	W1	HEAT-A	680	164	197	230	262	294	-	-	-	-	
				W1	HEAT-B	735	178	215	250	286	321	-	-	-	-	
				W1	HEAT-C	790	196	235	274	312	350	-	-	-	-	
				W1	HEAT-D	840	216	257	297	338	379	-	-	-	-	
				W1+W2	HEAT-A	1050	328	375	424	474	524	-	-	-	-	
				W1+W2	HEAT-B	1140	392	441	491	544	598	-	-	-	-	
				W1+W2	HEAT-C	1220	456	506	558	613	670	-	-	-	-	
				W1+W2	HEAT-D	1300	528	578	631	687	747	-	-	-	-	
			N072	W1	HEAT-A	1200	439	489	541	595	-	-	-	-	-	
				W1	HEAT-B	1300	528	578	631	687	-	-	-	-	-	
				W1	HEAT-C	1400	628	677	731	789	-	-	-	-	-	
				W1	HEAT-D	1475	710	759	812	871	-	-	-	-	-	
			D072	W1	HEAT-A	790	196	235	274	312	-	-	-	-	-	
				W1	HEAT-B	855	222	264	305	347	-	-	-	-	-	
				W1	HEAT-C	920	252	296	341	385	-	-	-	-	-	
				W1	HEAT-D	975	282	328	374	421	-	-	-	-	-	
				W1+W2	HEAT-A	1200	439	489	541	595	-	-	-	-	-	
				W1+W2	HEAT-B	1300	528	578	631	687	-	-	-	-	-	
				W1+W2	HEAT-C	1400	628	677	731	789	-	-	-	-	-	
				W1+W2	HEAT-D	1480	716	764	818	877	-	-	-	-	-	
		DNX	Cool	Low	Y1	COOL-A	900	198	233	272	313	358	406	458	512	569
					Y1	COOL-B	760	166	190	222	262	310	366	431	503	584
					Y1	COOL-C	830	180	210	245	286	332	384	441	503	571
					Y1	COOL-D	970	221	260	302	344	388	434	481	530	579
				High	Y1+Y2	COOL-A	1250	361	408	454	501	548	594	640	687	733
					Y1+Y2	COOL-B	1050	253	296	340	384	428	472	516	561	605
					Y1+Y2	COOL-C	1150	302	348	394	439	484	528	571	615	657
					Y1+Y2	COOL-D	1350	429	475	522	570	620	671	723	777	831
			Heat	N065	W1	HEAT-A	1200	330	377	423	469	515	560	-	-	-
					W1	HEAT-B	1300	394	440	487	535	583	631	-	-	-
					W1	HEAT-C	1400	467	511	558	607	659	713	-	-	-
					W1	HEAT-D	1500	550	590	635	686	743	804	-	-	-
				N090	W1	HEAT-A	1150	302	348	394	439	484	528	-	-	-
					W1	HEAT-B	1225	345	392	439	485	531	577	-	-	-
					W1	HEAT-C	1275	377	424	471	518	565	612	-	-	-
					W1	HEAT-D	1350	429	475	522	570	620	671	-	-	-
				D090	W1	HEAT-A	740	163	185	216	255	304	362	-	-	-
					W1	HEAT-B	785	170	196	230	270	317	372	-	-	-
					W1	HEAT-C	825	178	208	243	284	330	382	-	-	-
					W1	HEAT-D	870	189	223	260	301	347	396	-	-	-
W1+W2	HEAT-A				1150	302	348	394	439	484	528	-	-	-		
W1+W2	HEAT-B				1220	342	389	436	482	528	573	-	-	-		
W1+W2	HEAT-C				1280	380	427	474	521	568	616	-	-	-		
W1+W2	HEAT-D				1350	429	475	522	570	620	671	-	-	-		

DNX/DNY/BHX024-060 (Continued)

Size (Tons)	Model	Mode	Thermostat Input	Speed Tap	CFM	External Static Pressure (Inch Water Gauge)									
						0.2	0.3	0.4	0.5	0.6	0.7	0.8	0.9	1.0	
						Watts	Watts	Watts	Watts	Watts	Watts	Watts	Watts	Watts	
036 (3.0)	BHX	Cool	Low	Y1	COOL-A	900	140	165	191	217	245	273	303	333	364
				Y1	COOL-B	750	98	122	146	171	196	222	248	275	302
				Y1	COOL-C	825	118	142	167	192	219	246	273	302	331
				Y1	COOL-D	975	163	190	217	246	275	305	336	368	400
			High	Y1+Y2	COOL-A	1200	245	279	314	349	385	421	457	494	531
				Y1+Y2	COOL-B	1000	171	199	227	256	285	316	347	380	413
				Y1+Y2	COOL-C	1100	206	237	268	300	332	365	399	434	468
				Y1+Y2	COOL-D	1300	286	326	366	405	444	483	522	562	600
		Heat	Heat Pump	Y1	COOL-A	1200	245	279	314	349	385	421	457	494	531
				Y1	COOL-B	1000	171	199	227	256	285	316	347	380	413
				Y1	COOL-C	1100	206	237	268	300	332	365	399	434	468
				Y1	COOL-D	1300	286	326	366	405	444	483	522	562	600
			Heat Pump + Aux. Heat	Y1+W1	COOL-A; HEAT-A	1200	245	279	314	349	-	-	-	-	-
				Y1+W1	COOL-A; HEAT-B	1200	245	279	314	349	-	-	-	-	-
				Y1+W1	COOL-A; HEAT-C	1320	295	336	376	417	-	-	-	-	-
				Y1+W1	COOL-A; HEAT-D	1200	245	279	314	349	-	-	-	-	-
				Y1+W1	COOL-B; HEAT-A	1200	245	279	314	349	-	-	-	-	-
				Y1+W1	COOL-B; HEAT-B	1080	199	229	259	290	-	-	-	-	-
				Y1+W1	COOL-B; HEAT-C	1320	295	336	376	417	-	-	-	-	-
				Y1+W1	COOL-B; HEAT-D	1200	245	279	314	349	-	-	-	-	-
				Y1+W1	COOL-C; HEAT-A	1200	245	279	314	349	-	-	-	-	-
				Y1+W1	COOL-C; HEAT-B	1100	206	237	268	300	-	-	-	-	-
				Y1+W1	COOL-C; HEAT-C	1320	295	336	376	417	-	-	-	-	-
				Y1+W1	COOL-C; HEAT-D	1200	245	279	314	349	-	-	-	-	-
				Y1+W1	COOL-D; HEAT-A	1300	286	326	366	405	-	-	-	-	-
				Y1+W1	COOL-D; HEAT-B	1300	286	326	366	405	-	-	-	-	-
				Y1+W1	COOL-D; HEAT-C	1320	295	336	376	417	-	-	-	-	-
				Y1+W1	COOL-D; HEAT-D	1300	286	326	366	405	-	-	-	-	-
048 (4.0)	DNX DNY	Cool	Low	Y1	COOL-A	1030	237	280	323	367	411	455	499	543	588
				Y1	COOL-B	930	192	237	282	326	369	413	455	497	539
				Y1	COOL-C	1070	257	300	343	386	430	475	520	565	611
				Y1	COOL-D	1130	289	332	375	419	463	509	555	602	649
			High	Y1+Y2	COOL-A	1550	586	640	696	752	810	869	929	991	1053
				Y1+Y2	COOL-B	1400	466	513	561	611	663	715	770	826	882
				Y1+Y2	COOL-C	1600	630	687	745	804	864	926	988	1052	1116
				Y1+Y2	COOL-D	1700	723	787	851	916	982	1049	1116	1185	-
		Heat	N065	W1	HEAT-A	1200	330	373	416	461	507	554	-	-	-
				W1	HEAT-B	1300	394	439	484	531	579	629	-	-	-
				W1	HEAT-C	1400	466	513	561	611	663	715	-	-	-
				W1	HEAT-D	1500	544	596	648	702	758	815	-	-	-
			N090	W1	HEAT-A	1325	412	456	503	550	599	649	-	-	-
				W1	HEAT-B	1400	466	513	561	611	663	715	-	-	-
				W1	HEAT-C	1500	544	596	648	702	758	815	-	-	-
				W1	HEAT-D	1600	630	687	745	804	864	926	-	-	-
			D090	W1	HEAT-A	870	168	215	261	306	350	393	-	-	-
				W1	HEAT-B	920	188	233	278	322	366	409	-	-	-
				W1	HEAT-C	985	216	260	303	347	391	434	-	-	-
				W1	HEAT-D	1050	247	290	333	376	420	464	-	-	-
				W1+W2	HEAT-A	1330	415	460	506	554	603	653	-	-	-
				W1+W2	HEAT-B	1400	466	513	561	611	663	715	-	-	-
				W1+W2	HEAT-C	1500	544	596	648	702	758	815	-	-	-
				W1+W2	HEAT-D	1600	630	687	745	804	864	926	-	-	-
			N110	W1	HEAT-A	1450	504	553	604	656	-	-	-	-	-
				W1	HEAT-B	1500	544	596	648	702	-	-	-	-	-
				W1	HEAT-C	1600	630	687	745	804	-	-	-	-	-
				W1	HEAT-D	1700	723	787	851	916	-	-	-	-	-
			D110	W1	HEAT-A	940	196	241	285	329	-	-	-	-	-
				W1	HEAT-B	970	209	253	297	341	-	-	-	-	-
				W1	HEAT-C	1050	247	290	333	376	-	-	-	-	-
				W1	HEAT-D	1100	273	315	358	402	-	-	-	-	-
				W1+W2	HEAT-A	1450	504	553	604	656	-	-	-	-	-
				W1+W2	HEAT-B	1500	544	596	648	702	-	-	-	-	-
				W1+W2	HEAT-C	1600	630	687	745	804	-	-	-	-	-
				W1+W2	HEAT-D	1700	723	787	851	916	-	-	-	-	-

DNX/DNY/BHX024-060 (Continued)

Size (Tons)	Model	Mode	Thermostat Input	Speed Tap	CFM	External Static Pressure (Inch Water Gauge)									
						0.2	0.3	0.4	0.5	0.6	0.7	0.8	0.9	1.0	
						Watts	Watts	Watts	Watts	Watts	Watts	Watts	Watts	Watts	
048 (4.0)	BHX	Cool	Low	Y1	COOL-A	1050	184	216	248	280	313	346	380	414	448
				Y1	COOL-B	918	138	166	194	224	254	286	318	351	385
				Y1	COOL-C	984	160	190	220	251	282	315	348	381	416
				Y1	COOL-D	1115	210	243	277	311	345	379	414	449	484
			High	Y1+Y2	COOL-A	1600	448	500	551	600	647	693	736	779	819
				Y1+Y2	COOL-B	1400	338	383	426	468	509	549	589	627	664
				Y1+Y2	COOL-C	1500	391	439	486	532	576	618	660	700	739
				Y1+Y2	COOL-D	1700	508	565	620	672	723	772	818	863	905
		Heat	Heat Pump	Y1	COOL-A	1600	448	500	551	600	647	693	736	779	819
				Y1	COOL-B	1400	338	383	426	468	509	549	589	627	664
				Y1	COOL-C	1500	391	439	486	532	576	618	660	700	739
				Y1	COOL-D	1700	508	565	620	672	723	772	818	863	905
			Heat Pump + Aux. Heat	Y1+W1	COOL-A; HEAT-A	1600	448	500	551	600	647	693	736	779	819
				Y1+W1	COOL-A; HEAT-B	1600	448	500	551	600	647	693	736	779	819
				Y1+W1	COOL-A; HEAT-C	1760	546	606	663	718	771	821	870	916	959
				Y1+W1	COOL-A; HEAT-D	1600	448	500	551	600	647	693	736	779	819
				Y1+W1	COOL-B; HEAT-A	1600	448	500	551	600	647	-	-	-	-
				Y1+W1	COOL-B; HEAT-B	1440	359	405	449	493	535	-	-	-	-
				Y1+W1	COOL-B; HEAT-C	1760	546	606	663	718	771	-	-	-	-
				Y1+W1	COOL-B; HEAT-D	1600	448	500	551	600	647	-	-	-	-
				Y1+W1	COOL-C; HEAT-A	1600	448	500	551	600	647	-	-	-	-
				Y1+W1	COOL-C; HEAT-B	1500	391	439	486	532	576	-	-	-	-
				Y1+W1	COOL-C; HEAT-C	1760	546	606	663	718	771	-	-	-	-
				Y1+W1	COOL-C; HEAT-D	1600	448	500	551	600	647	-	-	-	-
Y1+W1	COOL-D; HEAT-A	1700	508	565	620	672	723	-	-	-	-				
Y1+W1	COOL-D; HEAT-B	1700	508	565	620	672	723	-	-	-	-				
Y1+W1	COOL-D; HEAT-C	1760	546	606	663	718	771	-	-	-	-				
Y1+W1	COOL-D; HEAT-D	1700	508	565	620	672	723	-	-	-	-				
060 (5.0)	DNX DNY	Cool	Low	Y1	COOL-A	1200	330	373	416	461	507	554	602	651	700
				Y1	COOL-B	1060	252	295	338	381	425	470	514	559	605
				Y1	COOL-C	1130	289	332	375	419	463	509	555	602	649
				Y1	COOL-D	1270	374	418	463	509	556	605	655	706	758
			High	Y1+Y2	COOL-A	1700	723	787	851	916	982	1049	1116	1185	1253
				Y1+Y2	COOL-B	1500	544	596	648	702	758	815	873	932	993
				Y1+Y2	COOL-C	1600	630	687	745	804	864	926	988	1052	1116
				Y1+Y2	COOL-D	1800	823	895	967	1039	1112	1185	1257	-	-
		Heat	N065	W1	HEAT-A	1200	330	373	416	461	507	554	-	-	-
				W1	HEAT-B	1300	394	439	484	531	579	629	-	-	-
				W1	HEAT-C	1400	466	513	561	611	663	715	-	-	-
				W1	HEAT-D	1500	544	596	648	702	758	815	-	-	-
			N090	W1	HEAT-A	1325	412	456	503	550	599	649	-	-	-
				W1	HEAT-B	1400	466	513	561	611	663	715	-	-	-
				W1	HEAT-C	1500	544	596	648	702	758	815	-	-	-
				W1	HEAT-D	1600	630	687	745	804	864	926	-	-	-
			D090	W1	HEAT-A	870	168	215	261	306	350	393	-	-	-
				W1	HEAT-B	920	188	233	278	322	366	409	-	-	-
				W1	HEAT-C	985	216	260	303	347	391	434	-	-	-
				W1	HEAT-D	1050	247	290	333	376	420	464	-	-	-
				W1+W2	HEAT-A	1330	415	460	506	554	603	653	-	-	-
				W1+W2	HEAT-B	1400	466	513	561	611	663	715	-	-	-
				W1+W2	HEAT-C	1500	544	596	648	702	758	815	-	-	-
				W1+W2	HEAT-D	1600	630	687	745	804	864	926	-	-	-
			N110	W1	HEAT-A	1450	504	553	604	656	709	763	-	-	-
				W1	HEAT-B	1500	544	596	648	702	758	815	-	-	-
				W1	HEAT-C	1600	630	687	745	804	864	926	-	-	-
				W1	HEAT-D	1700	723	787	851	916	982	1049	-	-	-
			D110	W1	HEAT-A	940	196	241	285	329	373	416	-	-	-
				W1	HEAT-B	985	216	260	303	347	391	434	-	-	-
				W1	HEAT-C	1035	239	282	326	369	413	457	-	-	-
				W1	HEAT-D	1100	273	315	358	402	446	491	-	-	-
				W1+W2	HEAT-A	1450	504	553	604	656	709	763	-	-	-
				W1+W2	HEAT-B	1500	544	596	648	702	758	815	-	-	-
				W1+W2	HEAT-C	1600	630	687	745	804	864	926	-	-	-
				W1+W2	HEAT-D	1700	723	787	851	916	982	1049	-	-	-

DNX/DNY/BHX024-060 (Continued)

Size (Tons)	Model	Mode	Thermostat Input	Speed Tap	CFM	External Static Pressure (Inch Water Gauge)									
						0.2	0.3	0.4	0.5	0.6	0.7	0.8	0.9	1.0	
						Watts	Watts	Watts	Watts	Watts	Watts	Watts	Watts	Watts	
060 (5.0)	BHX	Cool	Low	Y1	COOL-A	1200	138	176	211	244	275	303	329	352	374
				Y1	COOL-B	1130	61	98	133	163	190	213	232	247	260
				Y1	COOL-C	1270	208	246	283	318	353	386	418	448	478
			Y1	COOL-D	1340	272	310	348	386	423	460	497	533	570	
			High	Y1+Y2	COOL-A	1700	487	531	575	621	668	716	765	816	867
				Y1+Y2	COOL-B	1600	446	487	530	574	619	666	714	763	814
		Y1+Y2		COOL-C	1800	514	560	607	654	701	749	798	847	897	
		Heat	Heat Pump	Y1	COOL-A	1700	487	531	575	621	668	716	765	816	867
				Y1	COOL-B	1600	446	487	530	574	619	666	714	763	814
				Y1	COOL-C	1800	514	560	607	654	701	749	798	847	897
				Y1	COOL-D	1900	526	576	624	672	720	766	813	859	-
			Heat Pump + Aux. Heat	Y1+W1	COOL-A; HEAT-A	1900	526	576	624	672	720	-	-	-	-
				Y1+W1	COOL-A; HEAT-B	1975	526	578	628	677	723	-	-	-	-
				Y1+W1	COOL-A; HEAT-C	2150	495	554	607	656	699	-	-	-	-
				Y1+W1	COOL-A; HEAT-D	2070	515	570	622	671	716	-	-	-	-
				Y1+W1	COOL-B; HEAT-A	1900	526	576	624	672	720	-	-	-	-
				Y1+W1	COOL-B; HEAT-B	1975	526	578	628	677	723	-	-	-	-
				Y1+W1	COOL-B; HEAT-C	2150	495	554	607	656	699	-	-	-	-
				Y1+W1	COOL-B; HEAT-D	2070	515	570	622	671	716	-	-	-	-
				Y1+W1	COOL-C; HEAT-A	1900	526	576	624	672	720	-	-	-	-
				Y1+W1	COOL-C; HEAT-B	1975	526	578	628	677	723	-	-	-	-
				Y1+W1	COOL-C; HEAT-C	2150	495	554	607	656	699	-	-	-	-
				Y1+W1	COOL-C; HEAT-D	2070	515	570	622	671	716	-	-	-	-
				Y1+W1	COOL-D; HEAT-A	1900	526	576	624	672	720	-	-	-	-
Y1+W1	COOL-D; HEAT-B			1975	526	578	628	677	723	-	-	-	-		
Y1+W1	COOL-D; HEAT-C	2150	495	554	607	656	699	-	-	-	-				
Y1+W1	COOL-D; HEAT-D	2070	515	570	622	671	716	-	-	-	-				

DNZ/BHZ/DEZ024-060

Size (Tons)	Model	Unit Speed	External Static Pressure (Inch Water Gauge)														
			0.2			0.4			0.6			0.8			1.0		
			SCFM	W	RPM	SCFM	W	RPM	SCFM	W	RPM	SCFM	W	RPM	SCFM	W	RPM
024 (2.0)	DNZ	Low (1)	719	115	752	617	130	858	-	-	-	-	-	-	-	-	-
		Low/Medium (2)	781	137	789	691	155	891	-	-	-	-	-	-	-	-	-
		Medium (3)	902	187	858	824	207	949	734	223	1037	622	230	1116	-	-	-
		Medium/High (4)	-	-	-	937	258	998	845	270	1075	722	271	1146	-	-	-
		High (5)	-	-	-	-	-	-	933	316	1104	796	307	1162	-	-	-
	BHZ	Low (1)	721	82	600	611	97	705	-	-	-	-	-	-	-	-	-
		Low/Medium (2)	769	93	628	694	112	730	610	126	832	-	-	-	-	-	-
		Medium (3)	882	131	704	812	147	797	736	162	889	651	177	979	-	-	-
		Medium/High (4)	971	171	773	916	188	857	851	205	939	775	219	1019	681	230	1097
		High (5)	-	-	-	-	-	-	957	249	982	887	261	1052	788	266	1120
	DEZ	Low (1)	726	87	632	629	99	739	-	-	-	-	-	-	-	-	-
		Low/Medium (2)	768	97	651	679	110	754	-	-	-	-	-	-	-	-	-
		Medium (3)	883	131	704	812	147	797	736	162	889	651	177	979	-	-	-
		Medium/High (4)	990	170	755	934	187	839	868	202	920	791	216	1000	696	227	1078
		High (5)	-	-	-	-	-	-	985	245	952	913	257	1022	813	261	1090
030 (2.5)	DNZ	Low (1)	827	163	825	759	187	919	-	-	-	-	-	-	-	-	-
		Low/Medium (2)	988	251	914	916	269	992	831	282	1067	-	-	-	-	-	-
		Medium (3)	1113	322	984	1035	333	1047	941	337	1108	818	329	1162	-	-	-
		Medium/High (4)	1233	394	1050	1145	394	1099	1040	388	1145	901	367	1184	-	-	-
		High (5)	-	-	-	-	-	-	1078	425	1164	867	353	1173	-	-	-
	BHZ	Low (1)	828	110	673	759	125	771	-	-	-	-	-	-	-	-	-
		Low/Medium (2)	991	168	754	934	187	839	868	205	922	783	221	1003	-	-	-
		Medium (3)	1091	214	807	1041	234	883	983	253	958	910	269	1033	785	273	1106
		Medium/High (4)	1189	269	861	1144	288	927	1091	305	994	1027	318	1061	912	316	1132
		High (5)	-	-	-	1235	347	970	1186	360	1028	1125	368	1086	1007	352	1147
	DEZ	Low (1)	828	110	673	759	125	771	-	-	-	-	-	-	-	-	-
		Low/Medium (2)	953	153	735	894	172	823	824	189	909	-	-	-	-	-	-
		Medium (3)	1091	214	807	1041	234	883	983	253	958	910	269	1033	785	273	1106
		Medium/High (4)	1189	269	861	1144	288	927	1091	305	994	1027	318	1061	912	316	1132
		High (5)	-	-	-	1235	347	970	1186	360	1028	1125	368	1086	1007	352	1147

Additional Static Resistance

Size (Tons)	Model	CFM	Wet Indoor Coil	Economizer ¹	Filter/Frame Kit	Electric Heat		
024 (2.0)	DNZ DNY DNX	500	0.01	0.00	0.01	-		
		600	0.01	0.00	0.02	-		
		700	0.01	0.00	0.04	-		
		800	0.02	0.01	0.06	-		
		900	0.03	0.01	0.08	-		
		1000	0.04	0.01	0.10	-		
		1100	0.05	0.01	0.13	-		
	BHZ BHX DEZ	1200	0.06	0.02	0.16	-		
		500	0.01	0.00	0.01	0.02		
		600	0.01	0.00	0.02	0.03		
		700	0.01	0.00	0.02	0.03		
		800	0.01	0.01	0.02	0.03		
		900	0.01	0.01	0.02	0.04		
		1000	0.02	0.01	0.02	0.04		
030 (2.5)	DNZ	1100	0.03	0.01	0.03	0.05		
		1200	0.04	0.02	0.03	0.06		
		1300	0.04	0.03	0.03	0.06		
		700	0.01	0.00	0.04	-		
		800	0.02	0.01	0.06	-		
		900	0.03	0.01	0.08	-		
		1000	0.04	0.01	0.10	-		
	BHZ DEZ	1100	0.05	0.01	0.13	-		
		1200	0.06	0.02	0.16	-		
		1300	0.07	0.03	0.17	-		
		700	0.01	0.00	0.02	0.03		
		800	0.01	0.01	0.02	0.03		
		900	0.01	0.01	0.02	0.04		
		1000	0.02	0.01	0.02	0.04		
036 (3.0)	DNZ DNY DNX	1100	0.03	0.01	0.03	0.05		
		1200	0.04	0.02	0.03	0.06		
		1300	0.04	0.03	0.03	0.07		
		1400	0.05	0.04	0.03	0.08		
		700	0.01	0.00	0.02	0.03		
		800	0.01	0.01	0.02	0.03		
		900	0.01	0.01	0.02	0.04		
	BHZ BHX DEZ	1000	0.02	0.01	0.02	0.04		
		1100	0.03	0.01	0.03	0.05		
		1200	0.04	0.02	0.03	0.06		
		1300	0.04	0.03	0.03	0.07		
		1400	0.04	0.04	0.03	0.08		
		042 (3.5)	DNZ	1100	0.02	0.02	0.04	-
				1200	0.03	0.02	0.04	-
1300	0.04			0.02	0.05	-		
1400	0.05			0.03	0.05	-		
1500	0.06			0.04	0.06	-		
1600	0.07			0.04	0.07	-		
1700	0.07			0.04	0.08	-		
1800	0.08			0.04	0.09	-		
BHZ DEZ	1900		0.09	0.05	0.10	-		
	2000		0.09	0.05	0.11	-		
	1100		0.03	0.01	0.03	0.05		
	1200		0.04	0.02	0.03	0.06		
	1300		0.04	0.03	0.03	0.07		
	1400		0.04	0.04	0.03	0.08		
	1500	0.04	0.05	0.04	0.09			
	1600	0.04	0.06	0.05	0.10			
1700	0.05	0.07	0.05	0.11				
1800	0.05	0.07	0.06	0.11				
1900	0.06	0.08	0.06	0.11				
2000	0.07	0.08	0.07	0.12				

Additional Static Resistance (Continued)

Size (Tons)	Model	CFM	Wet Indoor Coil	Economizer ¹	Filter/Frame Kit	Electric Heat
048 (4.0)	DNZ DNY DNX	1100	0.02	0.02	0.04	-
		1200	0.03	0.02	0.04	-
		1300	0.04	0.02	0.05	-
		1400	0.05	0.03	0.05	-
		1500	0.06	0.04	0.06	-
		1600	0.07	0.04	0.07	-
		1700	0.07	0.04	0.08	-
		1800	0.08	0.04	0.09	-
		1900	0.09	0.05	0.10	-
		2000	0.09	0.05	0.11	-
	BHZ BHX DEZ	1100	0.03	0.01	0.03	0.05
		1200	0.04	0.02	0.03	0.06
		1300	0.04	0.03	0.03	0.07
		1400	0.04	0.04	0.03	0.08
		1500	0.04	0.05	0.04	0.09
		1600	0.04	0.06	0.05	0.10
		1700	0.05	0.07	0.05	0.11
		1800	0.05	0.07	0.06	0.11
		1900	0.06	0.08	0.06	0.11
		2000	0.07	0.08	0.07	0.12
060 (5.0)	DNZ DNY	1100	0.02	0.02	0.04	-
		1200	0.03	0.02	0.04	-
		1300	0.04	0.02	0.05	-
		1400	0.05	0.03	0.05	-
		1500	0.06	0.04	0.06	-
		1600	0.07	0.04	0.07	-
		1700	0.07	0.04	0.08	-
		1800	0.08	0.04	0.09	-
		1900	0.09	0.05	0.10	-
		2000	0.09	0.05	0.11	-
	BHZ BHX DEZ	1100	0.03	0.01	0.03	0.05
		1200	0.04	0.02	0.03	0.06
		1300	0.04	0.03	0.03	0.07
		1400	0.04	0.04	0.03	0.08
		1500	0.04	0.05	0.04	0.09
		1600	0.04	0.06	0.05	0.10
		1700	0.05	0.07	0.05	0.11
		1800	0.05	0.07	0.06	0.11
		1900	0.06	0.08	0.06	0.11
		2000	0.07	0.08	0.07	0.12

1. The pressure drop through the economizer is greater for 100% outdoor air than for 100% return air. If the resistance of the return air duct is less than 0.25 IWG, the unit will deliver less CFM during full economizer operation.

Gas Heat Minimum Supply Air

Size (Tons)	Model	Heat Size	Supply Air (CFM)			
			Cooling		Heating	
			Min	Max	Min	Max
024 (2.0)	DNZ	N036	600	1000	610	1330
		D056	600	1000	860	1730
	DNY	N036	450	900	610	1330
		N056	450	900	860	1730
	DNX	D056	450	900	860	1730
		N036	450	900	610	1330
030 (2.5)	DNZ	N056	750	1250	860	1730
		D056	750	1250	860	1730
		N036	1200	1500	610	1330
036 (3.0)	DNZ	N056	1200	1500	940	2070
		D056	1200	1500	940	2070
		N072	1200	1500	1110	2220
		D072	1200	1500	1110	2220
		N036	700	1350	610	1330
	DNY	N056	700	1350	940	2070
		D056	700	1350	940	2070
		N072	700	1350	1110	2220
		D072	700	1350	1110	2220
	DNX	N065	685	1350	1080	2370
		D090	685	1350	1070	1780
	042 (3.5)	DNZ	N065	1050	1750	1080
N090			1050	1750	1070	1780
D090			1050	1750	1070	1780
N065			1200	2000	1080	2370
048 (4.0)	DNZ	N090	1200	2000	1230	2290
		D090	1200	2000	1230	2290
		N110	1200	2000	1330	2220
		D110	1200	2000	1330	2220
		N065	930	1700	1080	2370
	DNY	N090	930	1700	1230	2290
		D090	930	1700	1230	2290
		N110	930	1700	1330	2220
		D110	930	1700	1330	2220
	DNX	N065	930	1700	1080	2370
		N090	930	1700	1230	2290
		D090	930	1700	1230	2290
N110		930	1700	1330	2220	
060 (5.0)	DNZ	D110	1500	2100	1330	2220
		N065	1500	2100	1080	2370
		N090	1500	2100	1230	2290
		D090	1500	2100	1230	2290
		N110	1500	2100	1330	2220
	DNY	N065	1060	1800	1080	2370
		N090	1060	1800	1230	2290
		D090	1060	1800	1230	2290
		N110	1060	1800	1330	2220
		D110	1060	1800	1330	2220

Electric Heat Minimum Supply Air

Size (Tons)	Model	Voltage	Minimum Supply Air (CFM)					
			Heater kW					
			5.0	7.5	10.0	15.0	20.0	25.0
024 (2.0)	BHZ BHX DEZ	208/230-1-60	800	800	800	-	-	-
		208/230-1-60	1000	1000	1000	1000	-	-
		208/230-3-60	1000	1000	1000	1000	-	-
030 (2.5)	BHZ DEZ	460-3-60	1000	1000	1000	1000	-	-
		208/230-1-60	800	800	800	1000	-	-
		208/230-3-60	1200	1200	1200	1200	-	-
036 (3.0)	BHZ BHX	208/230-1-60	1200	1200	1200	1200	-	-
		208/230-3-60	1200	1200	1200	1200	-	-
		460-3-60	1200	1200	1200	1200	-	-
	DEZ	208/230-1-60	1200	1200	1200	1200	-	-
		208/230-3-60	1200	1200	1200	1200	-	-
		460-3-60	1200	1200	1200	1200	-	-
042 (3.5)	BHZ	575-3-60	1200	1200	1200	1200	-	-
		208/230-1-60	-	-	1225	1225	-	-
		208/230-3-60	-	-	1225	1225	-	-
	DEZ	460-3-60	-	-	1225	1225	-	-
		208/230-1-60	-	-	1200	1200	-	-
		208/230-3-60	-	-	1200	1200	-	-
048 (4.0)	BHZ BHX	460-3-60	-	-	1600	1600	1600	1600
		208/230-1-60	-	-	1600	1600	1600	1600
		208/230-3-60	-	-	1600	1600	1600	1600
	DEZ	460-3-60	-	-	1600	1600	1600	1600
		208/230-1-60	-	-	1600	1600	1600	1600
		208/230-3-60	-	-	1600	1600	1600	1600
060 (5.0)	BHZ BHX	575-3-60	-	-	1750	1750	1750	1750
		208/230-1-60	-	-	1750	1750	1750	1750
		208/230-3-60	-	-	1750	1750	1750	1750
	DEZ	460-3-60	-	-	1900	1900	1900	1900
		208/230-1-60	-	-	1900	1900	1900	1900
		208/230-3-60	-	-	1900	1900	1900	1900

Indoor Blower Specifications

Size (Tons)	Model	Motor				
		HP	RPM	Eff.	SF	Frame
024 (2.0)	DNZ	1/2	Variable	0.8	1.0	48
	DNY					
	DNX					
	BHZ					
	BHX					
030 (2.5)	DNZ	1/2	Variable	0.8	1.0	48
	BHZ					
	DEZ					
036 (3.0)	DNZ	3/4	Variable	0.8	1.0	48
	DNY					
	BHZ					
	BHX					
042 (3.5)	DEZ	1/2	Variable	0.8	1.0	48
	DNX	1	Variable	0.8	1.0	48
	DNZ	1	Variable	0.8	1.0	48
048 (4.0)	BHZ	3/4	Variable	0.8	1.0	48
	BHX					
	DEZ					
060 (5.0)	DNZ	1	Variable	0.8	1.0	48
	DNY					
	BHZ					
	BHX					
	DEZ					

Electric Heat Multipliers

Nominal	Voltage		kW Capacity Multipliers ¹
	Applied		
240	208		0.75
	230		0.92
480	460		0.92
600	575		0.92

1. Electric heaters are rated at nominal voltage. Use this table to determine the electric heat capacity for heaters applied at lower voltages.

Sound Performance

Outdoor Sound Power Levels

Size (Tons)	Model	Sound Rating ¹ dB (A)	Octave Band Centerline Frequency (Hz)						
			125	250	500	1000	2000	4000	8000
024 (2.0)	DNZ	77	64	65.5	68	72.5	64.5	60.5	48.5
	DNY	80	66	70.5	74	74.5	72.5	67.5	64.5
	DNX	80	66	70.5	74	74.5	72.5	67.5	64.5
	BHZ	77	64	74	71	69	65.5	58	46
	BHX	75	65.5	66.5	69	69.5	64	62	57
	DEZ	80	72	70	65	76	66	72	58
030 (2.5)	DNZ	74	63.5	64.5	66.5	67	63	57.5	51.5
	BHZ	77	65	66.5	72	71.5	68.5	65.5	64.5
	DEZ	79	66	67	67	76	75	66	57
036 (3.0)	DNZ	74	66.5	66.5	69.5	68	63	59	49.5
	DNY	79.5	69	71.5	74	74	70.5	67	61
	DNX	80	70.5	71	74.5	74	71	67.5	64
	BHZ	78	67.5	67	73	73	69	64.5	61.5
	BHX	79	73	71.4	72	71	67	64.5	60
	DEZ	74	65	64	67	68	67	65	59
042 (3.5)	DNZ	79	70	70.5	73.5	73	69.5	67	66
	BHZ	77	64.5	67	71.5	72.5	69.5	64.5	59
	DEZ	74	64	65	68	69	63	59	57
048 (4.0)	DNZ	79	70.5	71	73.5	73	70	66	66
	DNY	80	71.5	71.5	73.5	74	69.5	65	63.5
	DNX	81	72.5	73	76	75.5	71	67.5	65
	BHZ	78	65	67	72	72	69	67.5	63
	BHX	80	70	71	75	74	70	66	67
	DEZ	80	71	72	74	73	69	67	62
060 (5.0)	DNZ	80	73	71.5	74.5	75	70.5	67	62.5
	DNY	81	73.5	73	76	75.5	71	66.5	61.5
	BHZ	85	70	72.5	79	79.5	76	73.5	73
	BHX	80	67	69	73.5	77	69	66.5	60
	DEZ	80	68	71	74	73	72	72	60

1. Rated in accordance with ARI 270 standard.

Electrical Data

DNZ024-060 Gas Heat

Size (Tons)	Volt	Compressors (each)			OD Fan Motors (each)	Supply Blower Motor	MCA ¹ (Amps)	Max Fuse ² / Breaker ³ Size (Amps)
		RLA	LRA	MCC	FLA	FLA		
024 (2.0)	208/230-1-60	12.8	60	20	1.2	4.1	21.3	30
	208/230-3-60	14.7	73	23	1.2	6.0	25.6	35
030 (2.5)	208/230-3-60	10.4	60	16	1.2	6.0	20.2	25
	460-3-60	4.5	31	7	0.6	3.0	9.2	15
036 (3.0)	208/230-1-60	15.4	83	24	1.2	6.0	26.5	35
	208/230-3-60	11.5	77	18	1.2	6.0	21.6	30
	460-3-60	5.1	35	8	0.8	3.0	10.1	15
042 (3.5)	208/230-1-60	18.6	105	29	1.2	7.6	32.1	40
	208/230-3-60	13.4	88	21	1.2	7.6	25.6	35
	460-3-60	6.4	39	10	0.8	3.8	12.6	15
048 (4.0)	208/230-1-60	20.5	109	32	1.7	7.6	34.9	45
	208/230-3-60	14.5	91	23	1.7	7.6	27.4	35
	460-3-60	7.0	46	11	1.0	3.8	13.6	20
060 (5.0)	208/230-1-60	26.4	134	41	1.8	7.6	42.4	60
	208/230-3-60	15.9	110	25	1.8	7.6	29.3	40
	460-3-60	7.7	52	12	0.9	3.8	14.3	20

1. Minimum Circuit Ampacity.
2. Maximum Over Current Protection per standard UL 1995.
3. Fuse or HACR circuit breaker size installed at factory or field installed.

DNY024-060 Gas Heat

Size (Tons)	Volt	Compressors (each)			OD Fan Motors (each)	Supply Blower Motor	MCA ¹ (Amps)	Max Fuse ² / Breaker ³ Size (Amps)
		RLA	LRA	MCC	FLA	FLA		
024 (2.0)	208/230-1-60	10.2	52	16	1.4	4.3	18.5	25
036 (3.0)	208/230-1-60	16.6	82	26	1.4	6.8	29	35
	208/230-3-60	11.1	58	17	1.4	6.8	22.1	30
	460-3-60	4.5	29	7	0.8	3.4	9.8	15
048 (4.0)	208/230-1-60	21.1	96	33	1.7	9.1	37.2	45
	208/230-3-60	13.4	88	21	1.7	9.1	27.6	35
	460-3-60	6.4	41	10	0.9	4.6	13.5	15
060 (5.0)	208/230-1-60	25.6	118	40	1.8	9.1	42.9	60
	208/230-3-60	17.6	135	28	1.8	9.1	32.9	40
	460-3-60	9.0	62	14	0.9	4.6	16.8	25

1. Minimum Circuit Ampacity.
2. Maximum Over Current Protection per standard UL 1995.
3. Fuse or HACR circuit breaker size installed at factory or field installed.

DNX024-048 Gas Heat

Size (Tons)	Volt	Compressors (each)			OD Fan Motors (each)	Supply Blower Motor	MCA ¹ (Amps)	Max Fuse ² / Breaker ³ Size (Amps)
		RLA	LRA	MCC	FLA	FLA		
024 (2.0)	208/230-1-60	10.2	52	16	1.4	4.3	18.1	25
036 (3.0)	208/230-1-60	16.6	82	26	0.9	9.1	30.7	40
	208/230-3-60	11.1	58	17	0.9	9.1	23.8	30
	460-3-60	4.5	29	7	0.5	4.6	10.7	15
048 (4.0)	208/230-1-60	21.1	96	33	1.8	9.1	36.3	45
	208/230-3-60	13.4	88	21	1.8	9.1	26.7	35
	460-3-60	6.4	41	10	0.9	4.6	13.0	15

1. Minimum Circuit Ampacity.
2. Maximum Over Current Protection per standard UL 1995.
3. Fuse or HACR circuit breaker size installed at factory or field installed.

BHX024-060 Heat Pump With/Without Electric Heat

Size (Tons)	Volt	Compressors (each)			OD Fan Motors (each)	Supply Blower Motor	Electric Heat Option				MCA ¹ (Amps)	Max Fuse ² / Breaker ³ Size (Amps)	
		RLA	LRA	MCC	FLA	FLA	Model	kW	Stages	Amps			
024 (2.0)	208/230-1-60	10.2	52	16	0.9	4.3	None	-	-	-	18	25	
							2NH04500506	3.8/5	1	18.1/20.8	40.5/44	45/45	
							2NH04500706	5.6/7.5	2	27.1/31.3	51.8/57	60/60	
							2NH04501006	7.5/10	2	36.1/41.7	63.1/70	70/80	
036 (3.0)	208/230-1-60	16.6	82	26	1.1	6.8	None	-	-	-	28.7	35	
							2NH04500506	3.8/5	1	18.1/20.8	51.2/54.7	60/60	
							2NH04500706	5.6/7.5	2	27.1/31.3	62.5/67.7	70/70	
							2NH04501006	7.5/10	2	36.1/41.7	73.8/80.7	80/90	
	208/230-3-60	11.1	58	17	1.1	6.8	2NH04501506	11.3/15	2	54.2/62.5	96.4/106.8	100/110	
							None	-	-	-	21.8	30	
							2NH04501025	7.5/10	1	20.8/24.1	47.8/51.8	50/60	
							2NH04501525	11.3/15	1	31.3/36.1	60.9/66.9	70/70	
	460-3-60	4.5	29	7	0.6	3.4	None	-	-	-	9.6	15	
							2NH04501046	10	1	12	24.7	25	
							2NH04501546	15	1	18	32.2	35	
							None	-	-	-	35.8	45	
048 (4.0)	208/230-1-60	21.1	96	33	2.6	6.8	2NP04501006	7.5/10	2	36.1/41.7	80.9/87.9	90/90	
							2NP04501506	11.3/15	2	54.2/62.5	103.5/113.9	110/125	
							2NP04502006	15/20	2	72.2/83.3	126.1/139.9	150/150	
							2NP04502506	18.8/25	2	90.3/104.2	148.6/166	150/175	
	208/230-3-60	13.4	88	21	2.6	6.8	None	-	-	-	26.2	35	
							2NP04501025	7.5/10	1	20.8/24.1	52.2/56.2	60/60	
							2NP04501525	11.3/15	1	31.3/36.1	65.2/71.3	70/80	
							2NP04502025	15/20	2	41.7/48.1	78.3/86.3	80/90	
	460-3-60	6.4	41	10	1.3	3.4	2NP04502525	18.8/25	2	52.1/60.1	91.3/101.3	100/110	
							None	-	-	-	12.7	15	
							2NP04501046	10	1	12	27.7	30	
							2NP04501546	15	1	18	35.3	40	
	060 (5.0)	208/230-1-60	25.6	118	40	2.5	9.1	2NH04502046	20	2	24.1	42.8	45
								2NH04502546	25	2	30.1	50.3	60
								None	-	-	-	43.6	60
								2NP04501006	7.5/10	2	36.1/41.7	88.7/95.7	100/110
208/230-3-60		17.6	135	28	2.5	9.1	2NP04501506	11.3/15	2	54.2/62.5	111.3/121.7	125/125	
							2NP04502006	15/20	2	72.2/83.3	133.9/147.8	150/150	
							2NP04502506	18.8/25	2	90.3/104.2	156.4/173.8	175/175	
							None	-	-	-	33.6	45	
460-3-60		9.0	62	14	1.3	4.6	2NH04501025	7.5/10	1	20.8/24.1	59.7/63.7	70/70	
							2NH04501525	11.3/15	1	31.3/36.1	72.7/78.7	80/80	
							2NP04502025	15/20	2	41.7/48.1	85.7/93.7	90/100	
							2NH04502525	18.8/25	2	52.1/60.1	98.8/108.8	100/110	
460-3-60	9.0	62	14	1.3	4.6	None	-	-	-	17.2	25		
						2NP04501046	10	1	12	32.2	35		
						2NH04501546	15	1	18	39.7	40		
						2NH04502046	20	2	24.1	47.2	50		
460-3-60	9.0	62	14	1.3	4.6	2NP04502546	25	2	30.1	54.7	60		

1. Minimum Circuit Ampacity.
2. Maximum Over Current Protection per standard UL 1995.
3. Fuse or HACR circuit breaker size installed at factory or field installed.

Weights and Dimensions

DNX, DNY, DNZ, BHX, BHZ AND DEZ Unit Weights

Unit 4 Point Load Weight

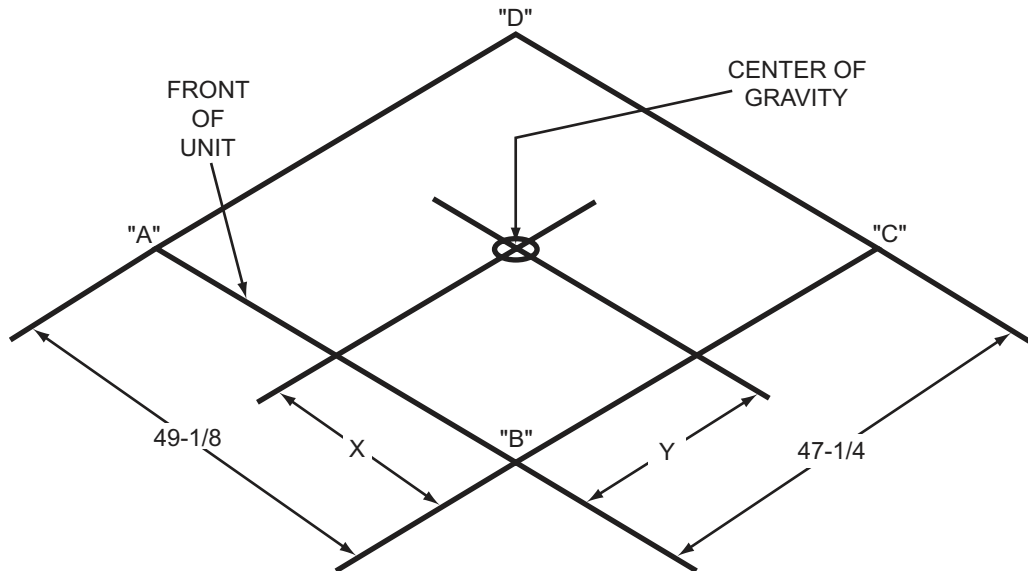

Size (Tons)	Model	Weight (lbs.)		Center of Gravity		4 Point Load Location (lbs.)			
		Shipping	Operating	X	Y	A	B	C	D
024 (2.0)	DNZ	365	360	24	25	91	92	89	88
	DNY	405	400	20	24.5	116	84	84	117
	DNX	445	440	20	24.5	127	93	93	127
	BHZ	360	355	22.25	25	96	84	81	93
	BHX	385	380	22.25	25	103	90	87	100
	DEZ	358	353	23	26	97	90	80	86
030 (2.5)	DNZ	395	390	24	24.75	98	99	97	96
	BHZ	355	350	22.25	25	96	84	81	93
	DEZ	373	368	23	25	97	90	87	94
036 (3.0)	DNZ	400	395	24	25	100	101	98	96
	DNY	445	440	20	24.25	126	91	93	129
	DNX	485	480	20	24	136	98	103	143
	BHZ	395	390	22.25	25	106	92	89	102
	BHX	405	400	21.75	24.25	108	90	92	110
	DEZ	373	368	23	25	97	90	87	94
042 (3.5)	DNZ	470	465	21	24.8	131	103	101	129
	BHZ	445	440	22.25	25	120	104	101	115
	DEZ	388	383	22.5	24	99	88	92	104
048 (4.0)	DNZ	475	470	21	24.8	133	104	102	130
	DNY	505	500	20	24	142	102	107	149
	DNX	505	500	20	24	142	102	107	149
	BHZ	490	485	22.25	25	132	115	111	127
	BHX	445	440	22	26	126	107	95	112
	DEZ	417	412	22	24.5	111	95	95	111
060 (5.0)	DNZ	545	540	20	24	153	110	116	161
	DNY	545	540	20	24	153	110	116	161
	BHZ	500	495	22.25	25	135	117	113	130
	BHX	465	460	22	26.25	133	113	99	116
	DEZ	467	462	24	25.5	119	121	112	111

Unit Accessory Weights

Unit Accessory	Model	Weight (lbs.)	
		Shipping	Operating
Add Economizer	All	45	40
Add Electric Heat ¹	BHX, BHZ, DEZ	13	12

1. Weight given is for the maximum heater size available (25 kW).

Gas Unit Dimensions

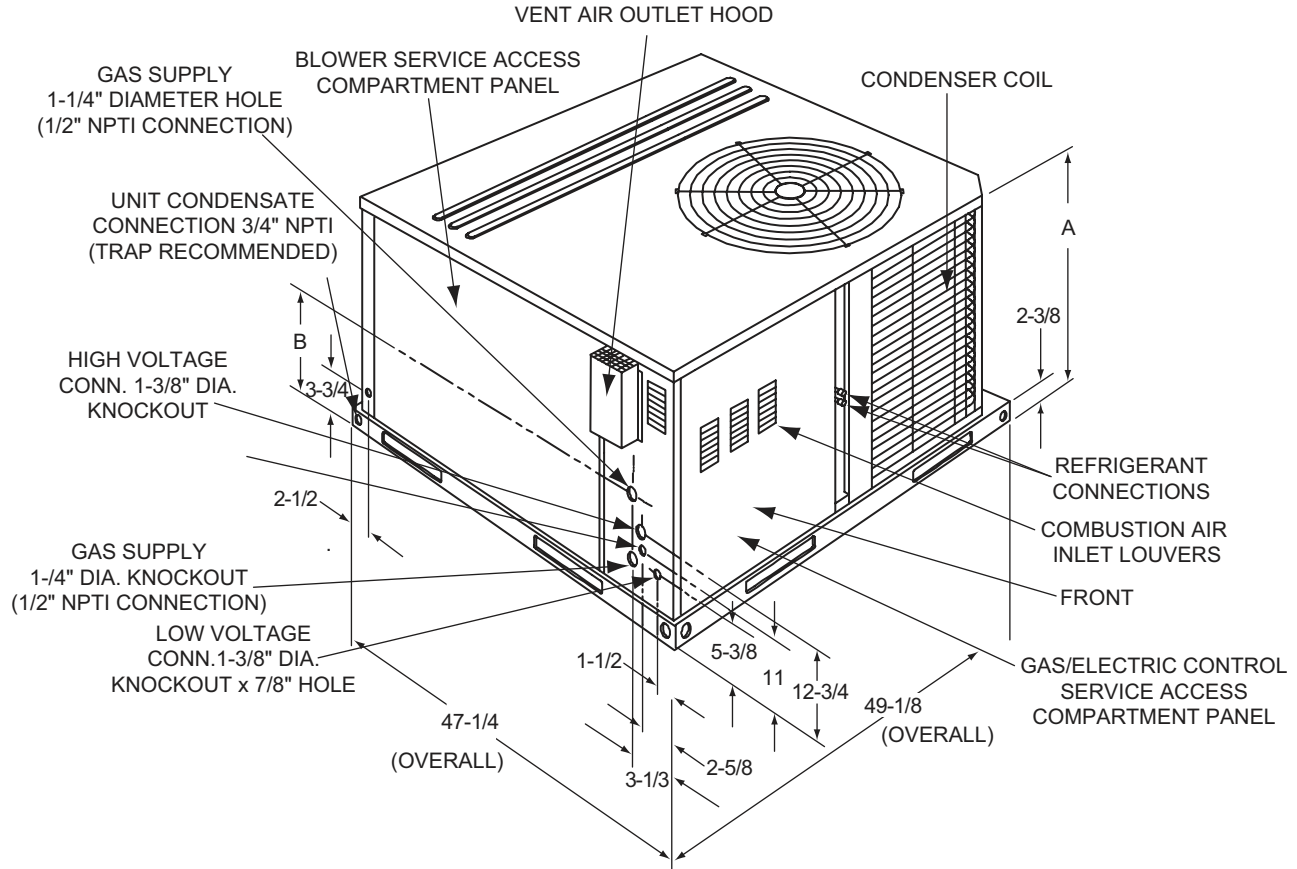

Gas Unit Dimensions

Unit Size	Dimensions	
	"A"	"B"
024, 030, 036 ¹	33-1/2	18-1/4
036 ² , 042, 048, 060	41-1/2	23-1/8

- 1. DNY, DNZ Models
- 2. DNX Models

Gas Unit Clearances^{1 2}

Direction	Distance (in.)	Direction	Distance (in.)
Top ³	36	Right	12
Front	36	Left	24
Rear	0	Bottom ⁴	0

- 1. A 1" clearance must be provided between any combustible material and the supply air duct work.
- 2. The products of combustion must not be allowed to accumulate within a confined space and recirculate.
- 3. Units must be installed outdoors. Over hanging structure or shrubs should not obscure condenser air discharge outlet.
- 4. Units may be installed on combustible floors made from wood or class A, B or C roof covering materials.

Heat Pump Unit Dimensions

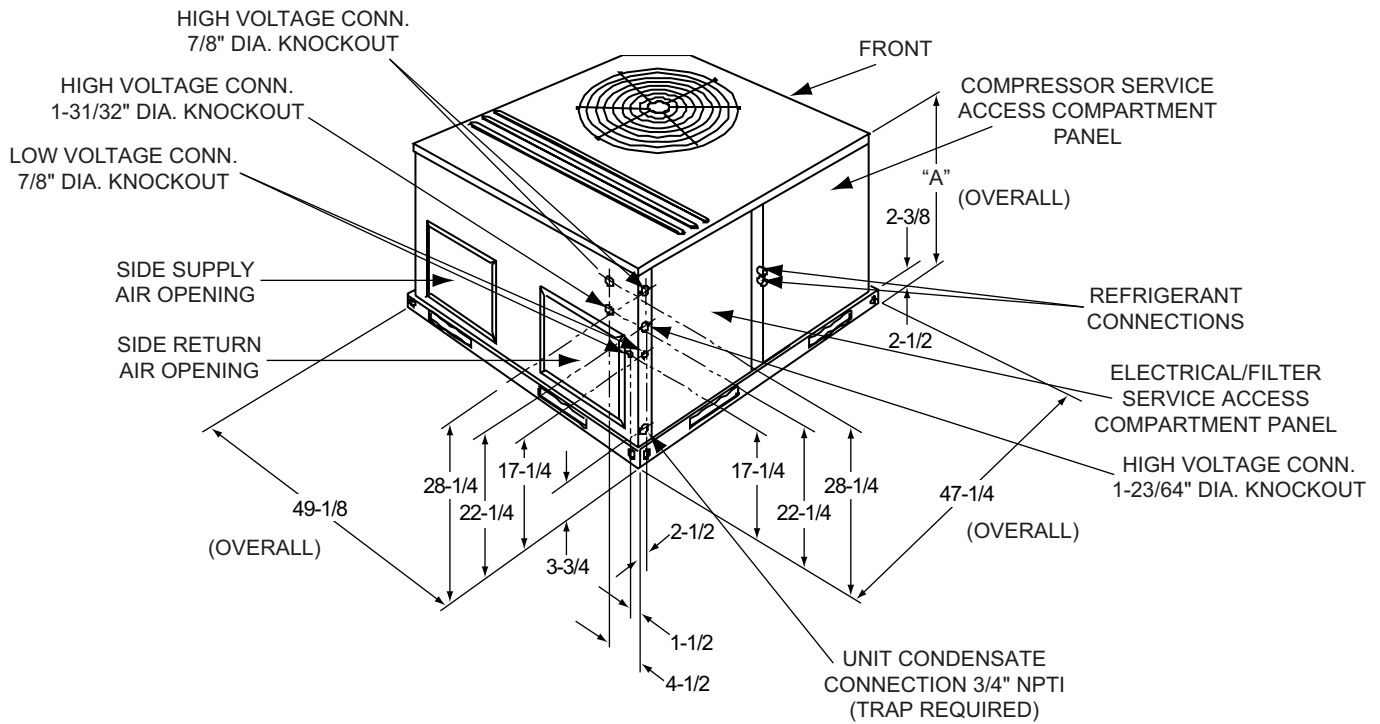

Heat Pump Unit Dimensions

Unit Size	Dimensions
	"A"
024, 036	33-1/2
042 ¹ , 048, 060	41-1/2

1. BHZ Models.

Cooling Only Unit Dimensions

Unit Size	Dimensions
	"A"
024, 030, 036, 042	33-1/2
048, 060	41-1/2

Cooling Only and Heat Pump Unit Clearances

Direction	Distance (in.)	Direction	Distance (in.)
Top ¹	36	Right	24
Front	12	Left	24
Rear	0	Bottom ^{2 3}	0

- Units must be installed outdoors. Over hanging structure or shrubs should not obscure condenser air discharge outlet.
- Units may be installed on combustible floors made from wood or class A, B or C roof covering materials.
- Minimum Clearance of 1 inch all sides of supply air duct for the first 3 foot of duct for 20 & 25 kW., zero inches there after. For all other heaters, zero inch clearance all sides for entire length of duct.

Note: For units applied with a roof curb, the minimum clearance may be reduced from 1 inch to 1/2 inch between combustible roof curb material and this supply air duct.

Unit Dimensions Front and Bottom

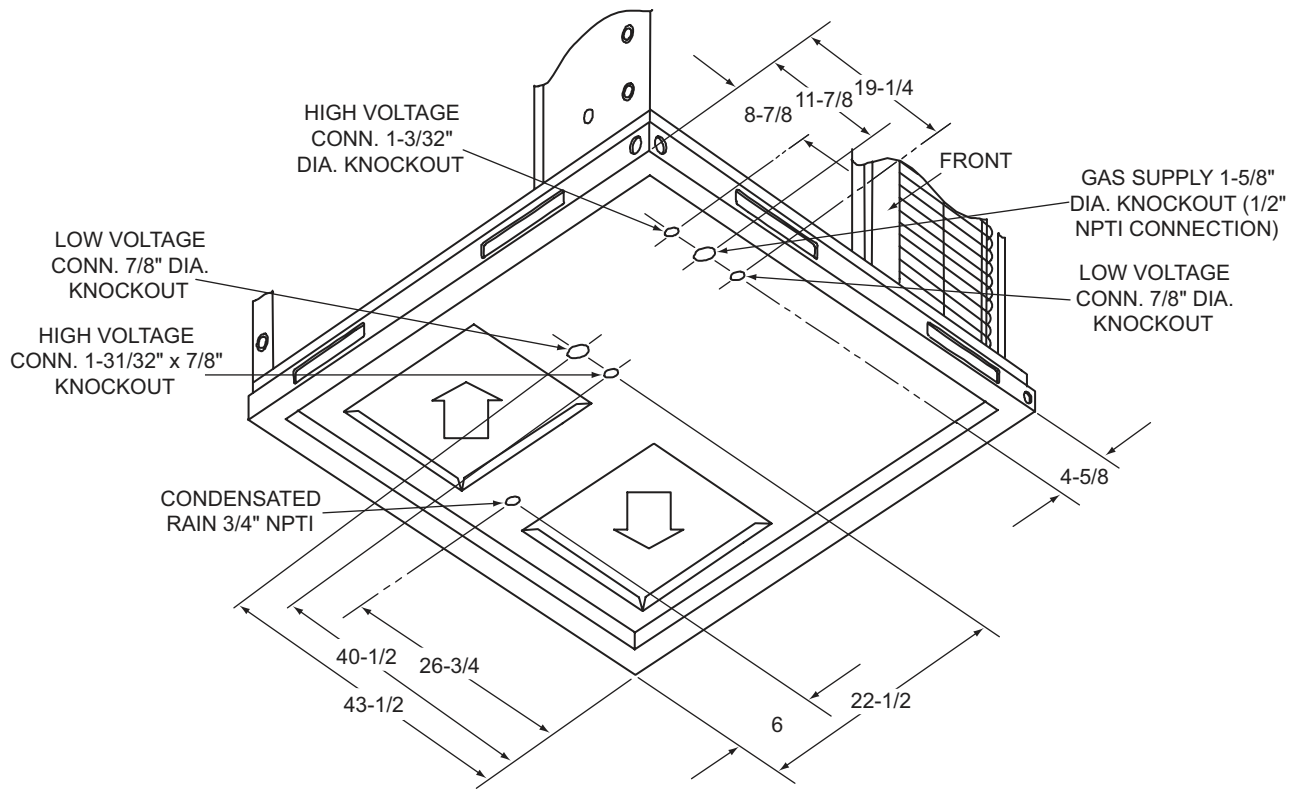

Unit Dimensions Back and Bottom

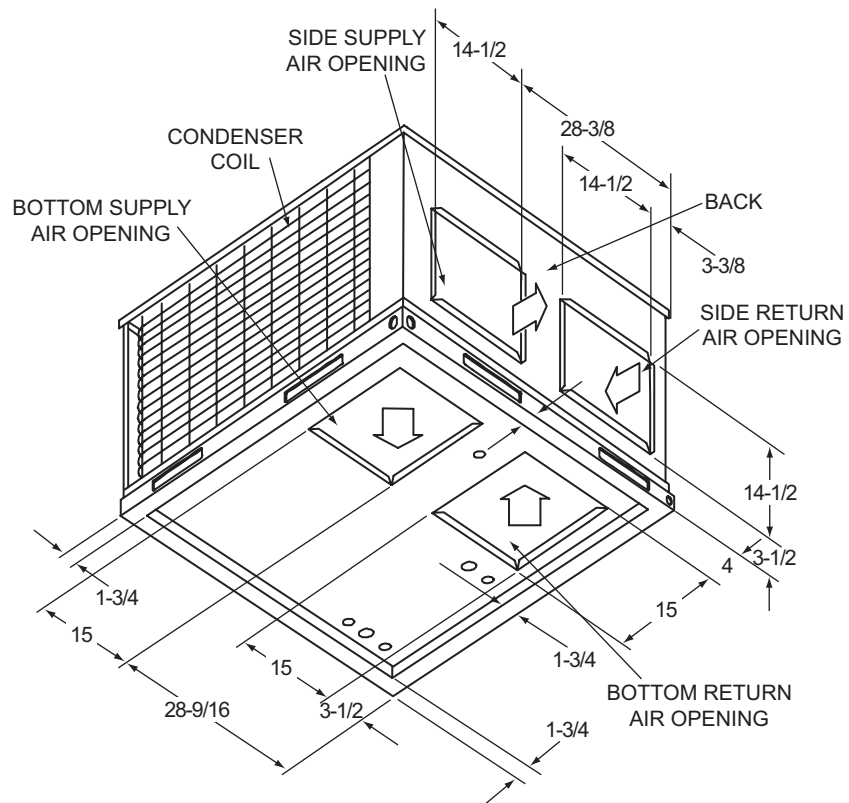

Unit Typical Duct Applications

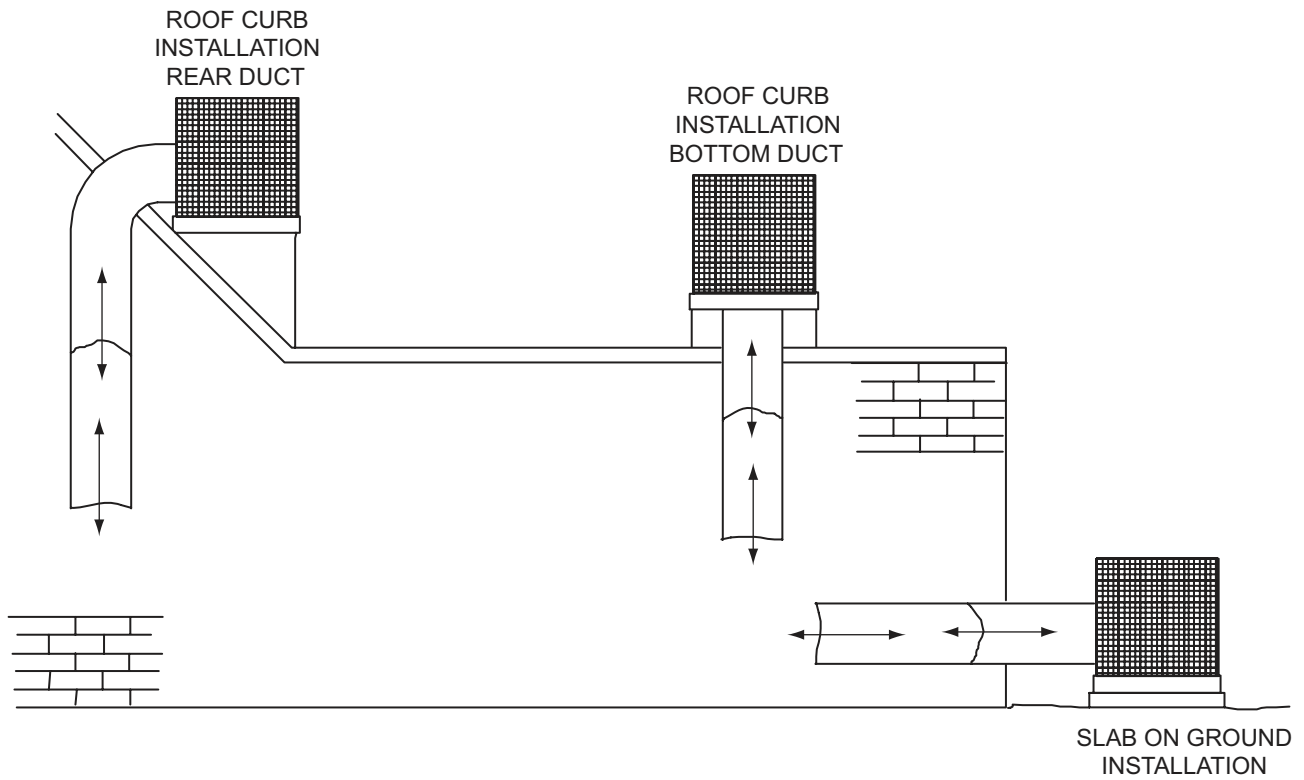

Unit Typical Slab on Ground Installation (Gas Model Shown)

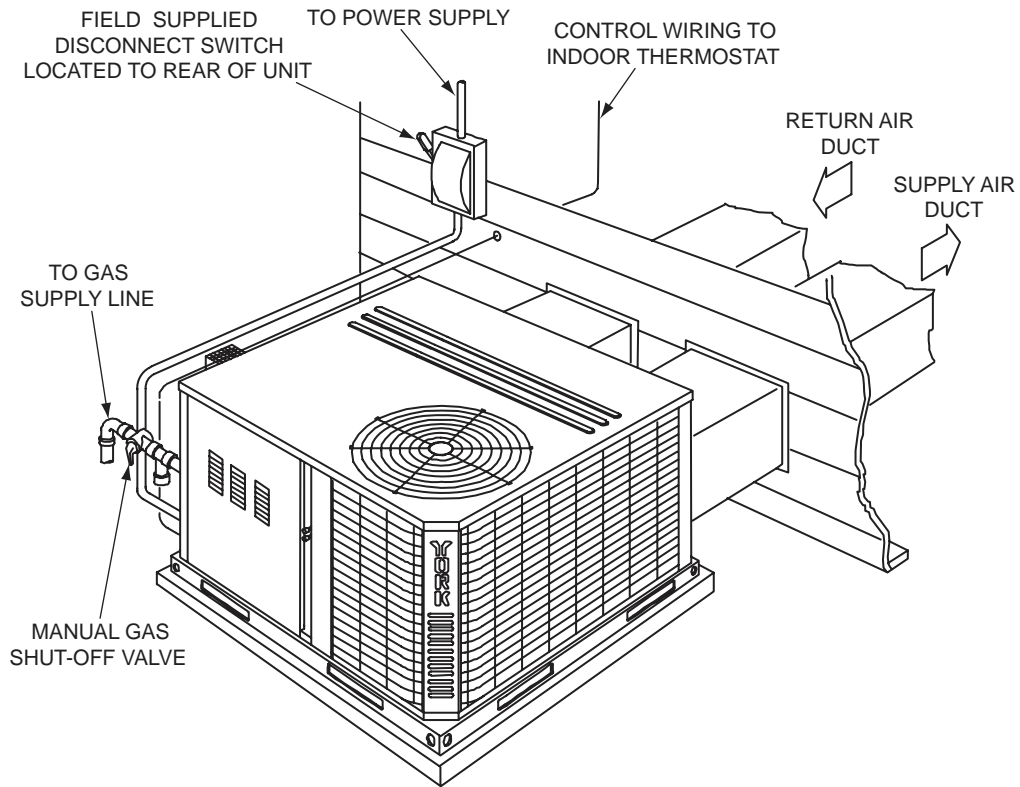

Unit Typical Roof Curb Installation (Gas Model Shown)

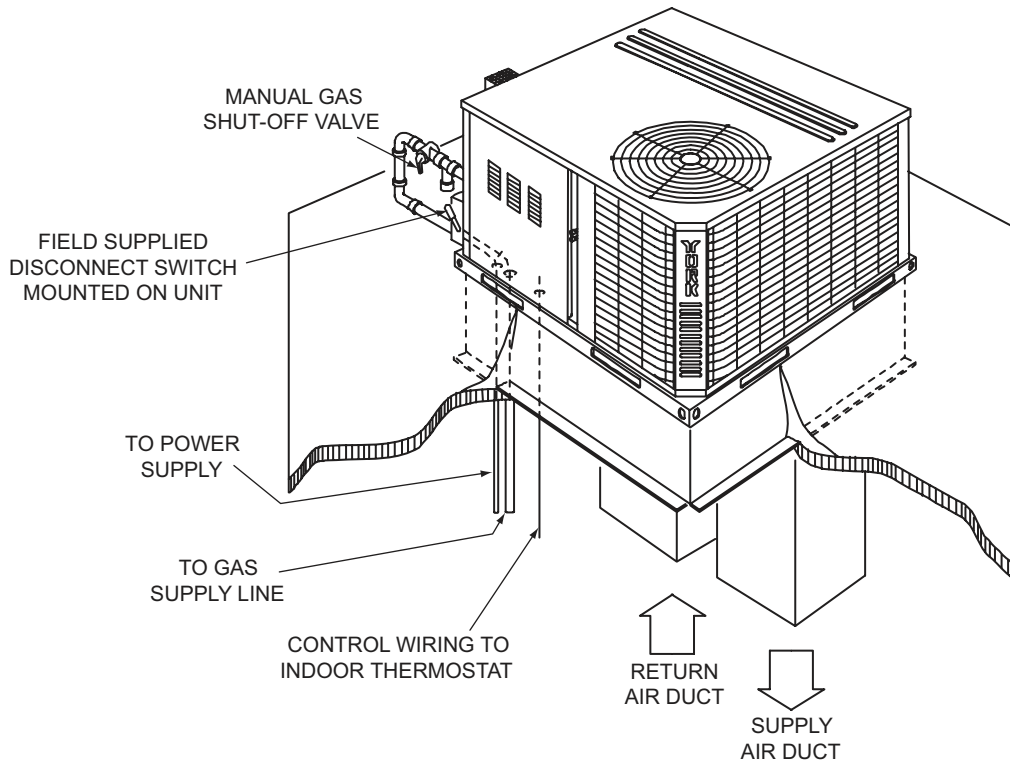

Unit Accessory Dimensions

Roof Curb¹

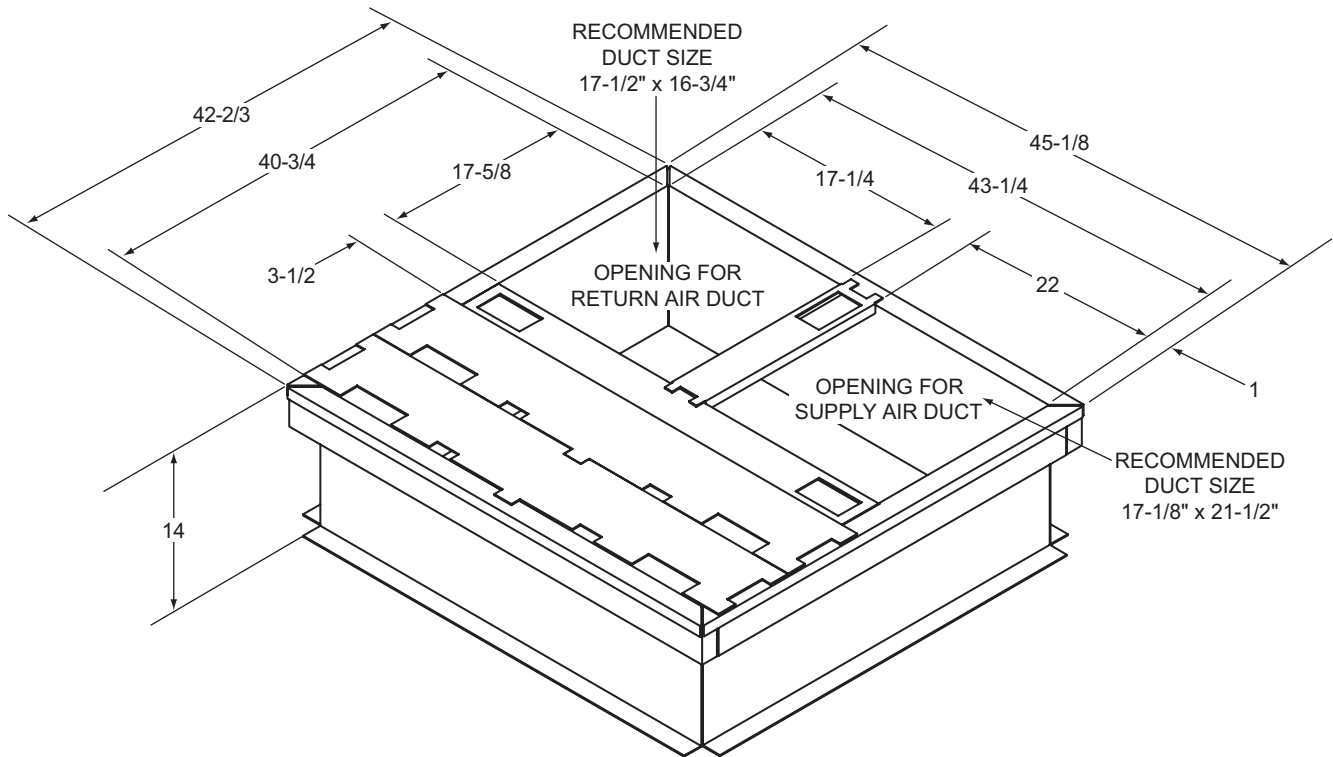

1. 8" Roof Curb also available.

Roof Curb Cross Section

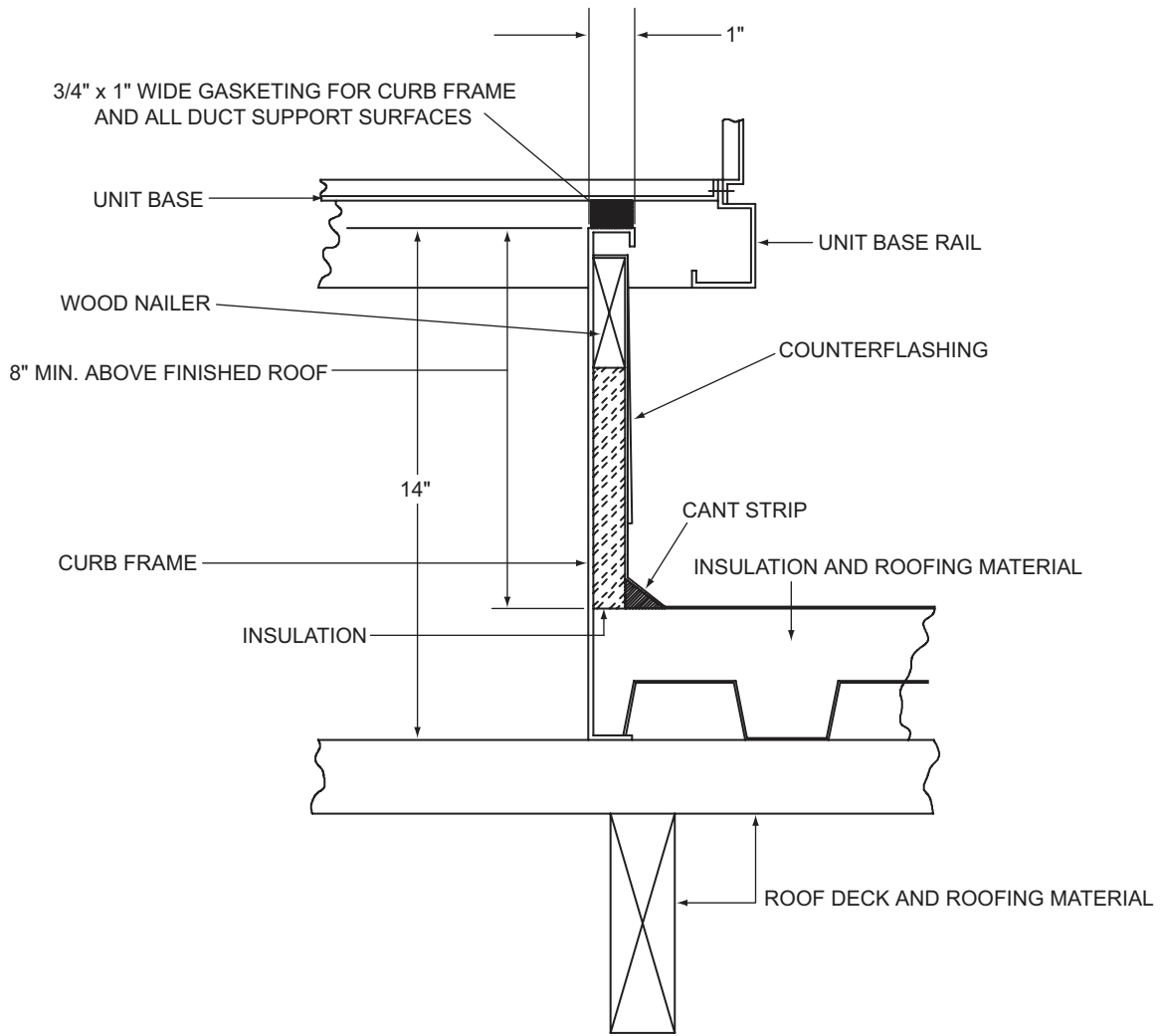

VENSTAR®

COMMERCIAL THERMOSTAT

MODEL NO. T2950

365-DAY PROGRAMMABLE

UP TO 3-HEAT
& 2-COOL

HEAT
COOL & HEAT
PUMP

TITLE-24 COMPLIANT

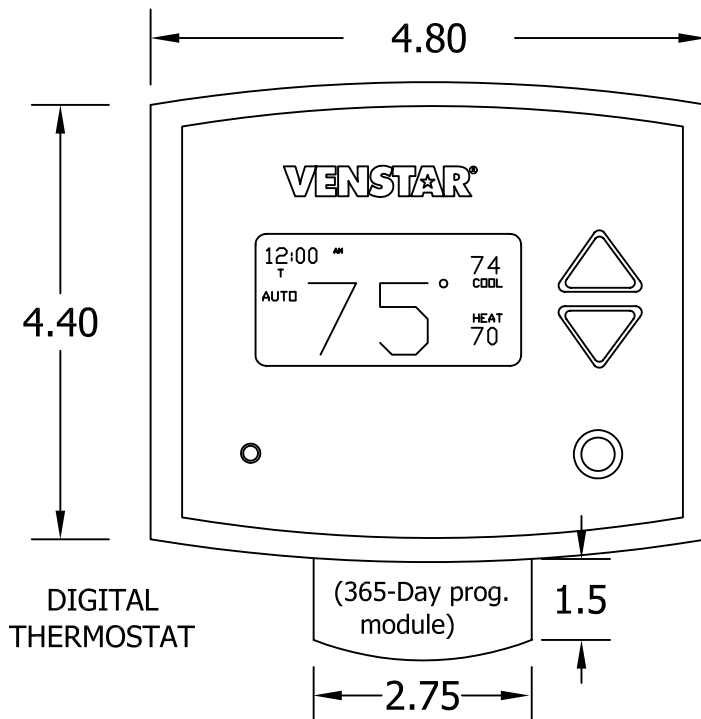

STANDARD FEATURES:

- **365-day programmable (up to 10 years, includes full calendar with preprogrammed holidays)**
- Up to 3-Occupied, 1-Unoccupied periods per day, with copy command for easy programming
- **Light Activated occupied period (defeatable)**
- **Auto changeover, 3-stage heat, 2-stage cool for use with gas/electric, heat pump, split systems, electric & hydronic heat**
- Configurable for manual changeover, also configurable programmable or non-programmable
- Adjustable deadbands and timers
- 2 configurable outputs for maximum flexibility. Can be used for humidification, dehumidification, 3rd stage heating or programmable output for lighting, exhaust fans, remote sensor etc.
- Energy Watch keeps track of energy use by tracking heating and cooling hours
- Smart Fan (keeps the fan from running during unoccupied periods)
- Smart recovery (reaches selected comfort temperature at exact time is scheduled for energy savings)
- **Pre-occupancy fan purge**
- Display shows both heating and cooling setpoints and room temperature simultaneously
- All programming and setpoints stored in non-volatile memory, and are never lost in power failure
- Service filter and service UV lamp indicators
- Red/Green LED shows whether thermostat is calling for heating or cooling
- **5-minute compressor time guard and adjustable cycle limit, both defeatable for servicing equipment**
- Thermoglow backlit electro-luminous display and backlit color coded keys and legends

ACCESORY FEATURES:

- **Accepts humidification/dehumidification control module (Venstar part number ACC0430)**
- **Control to, or monitor a second remote sensor. Can average up to 8 (wired or wireless) remote sensors (Venstar part number ACC0401)**
- Outdoor sensor ready with high and low temperature of the day (Venstar part number ACC0400)
- Accepts accessory IR remote control system (Venstar part number ACC0431)
- Accepts accessory EZ Programmer- programmed via USB through computer (Venstar part number ACC0)
- **For accessory locking cover use (Venstar part number ACC0620)**

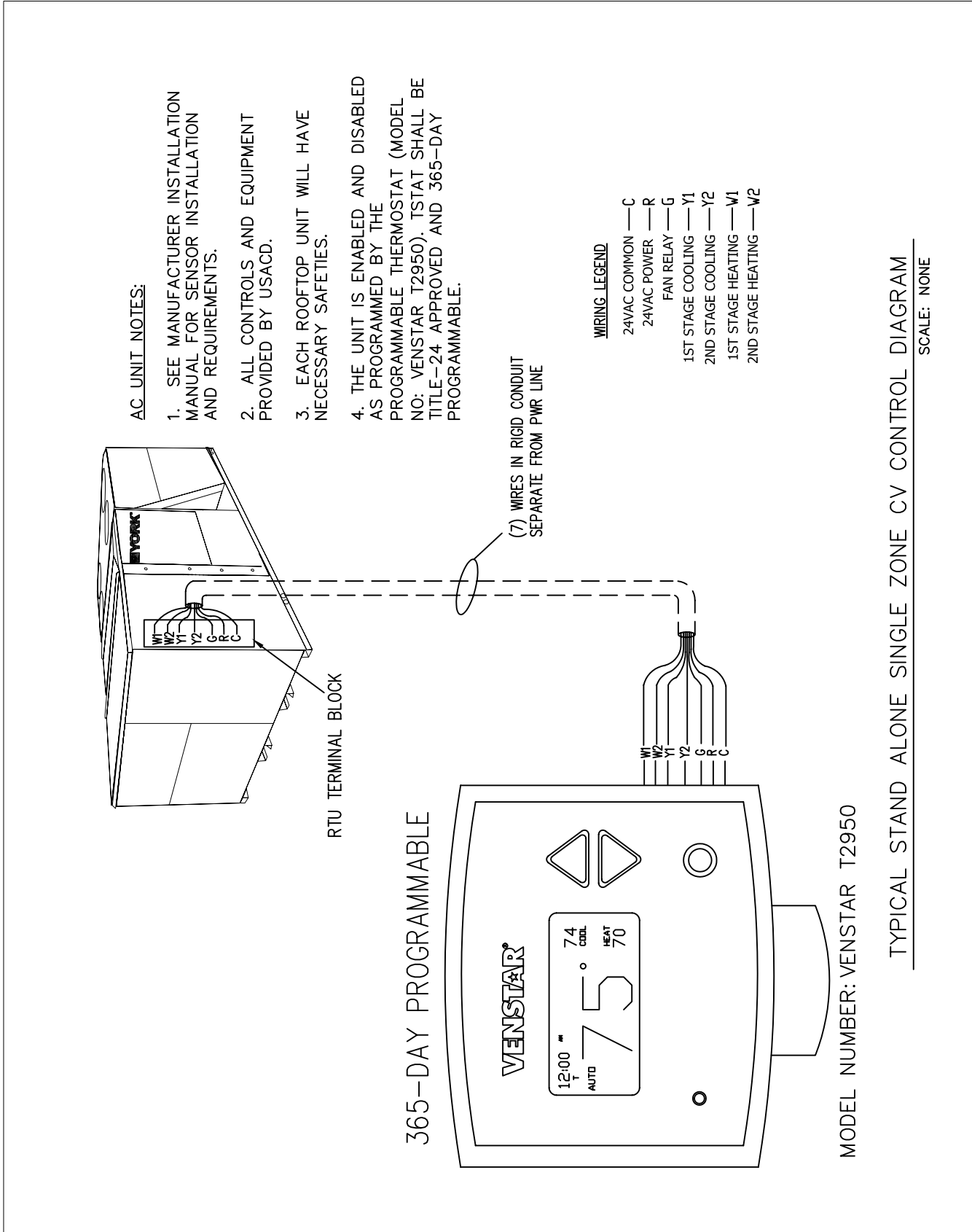

AC UNIT NOTES:

1. SEE MANUFACTURER INSTALLATION MANUAL FOR SENSOR INSTALLATION AND REQUIREMENTS.
2. ALL CONTROLS AND EQUIPMENT PROVIDED BY USACD.
3. EACH ROOFTOP UNIT WILL HAVE NECESSARY SAFETIES.
4. THE UNIT IS ENABLED AND DISABLED AS PROGRAMMED BY THE PROGRAMMABLE THERMOSTAT (MODEL NO: VENSTAR T2950). TSTAT SHALL BE TITLE-24 APPROVED AND 365-DAY PROGRAMMABLE.

WIRING LEGEND

- 24VAC COMMON — C
- 24VAC POWER — R
- FAN RELAY — G
- 1ST STAGE COOLING — Y1
- 2ND STAGE COOLING — Y2
- 1ST STAGE HEATING — W1
- 2ND STAGE HEATING — W2

365-DAY PROGRAMMABLE

MODEL NUMBER: VENSTAR T2950

TYPICAL STAND ALONE SINGLE ZONE CV CONTROL DIAGRAM

SCALE: NONE

COMMERCIAL ZONING PACKAGE

FACILITY EXPLORER

BY JOHNSON CONTROLS

The Facility Explorer Commercial Zoning Package is a complete, turnkey control system used to improve occupant comfort in a building (or section of a building) that is conditioned with a packaged rooftop HVAC unit. It accomplishes this by varying the amount of conditioned air delivered to individual zones and by intelligently cycling the rooftop unit's heating and cooling stages to best satisfy all the zone demands.

Manufacturer Independent

The Facility Explorer Commercial Zoning Package is designed to work with any standard, packaged HVAC equipment, regardless of manufacturer. This allows you to apply this control package to equipment provided by a variety of suppliers or to equipment that has already been installed. This flexibility makes the Facility Explorer Commercial Zoning Package perfectly suited for both new and retrofit installations.

Affordable Intelligence

The Facility Explorer Commercial Zoning Package utilizes the distributed application architecture of the FX16 Master Controller. This feature allows direct communications to occur between the FX16 and all the zone controllers. This means that there is no need for a traditional supervisory class controller to manage the data sharing. This direct communication flow allows the FX16 to monitor each zone's status to intelligently determine the proper mode of operation for the rooftop unit.



COMMERCIAL ZONING PACKAGE

Easy Installation

Several pieces of the Facility Explorer Commercial Zoning Package can be ordered pre-assembled from the factory to simplify installation:

- Zone Controller and Actuator Assembly (FXZAN)
 - The FX05 Field Controller is combined with an M9104AGA non-spring return actuator and an electrical termination wiring block, all in one packaged assembly
 - Perfect for retrofit installations where the zone damper is already installed
- Zone Controller, Actuator, and Damper Assembly
 - FXZAN Zone Controller and Actuator Assembly is combined with a round or rectangular zone damper
 - Perfect for new installations or for retrofit installations where the zone damper has not yet been installed

- Bypass Damper and Actuator Assembly
 - A round or rectangular bypass damper is combined with an M910xHGA non-spring return actuator
- FX16 Master Controller with Pre-Downloaded Zoning Application
 - FX16 Master Controller can be ordered with the commercial zoning application pre-downloaded
 - Once installed, the FX16 takes care of downloading the corresponding parts of the zoning application to each of the zone controllers
 - Eliminates the downloading steps from the field installation and startup
 - This provides the possibility (with an onsite Medium User Interface) to download, configure and commission the entire system, including the rooftop, bypass, and all zone controllers without any software tool

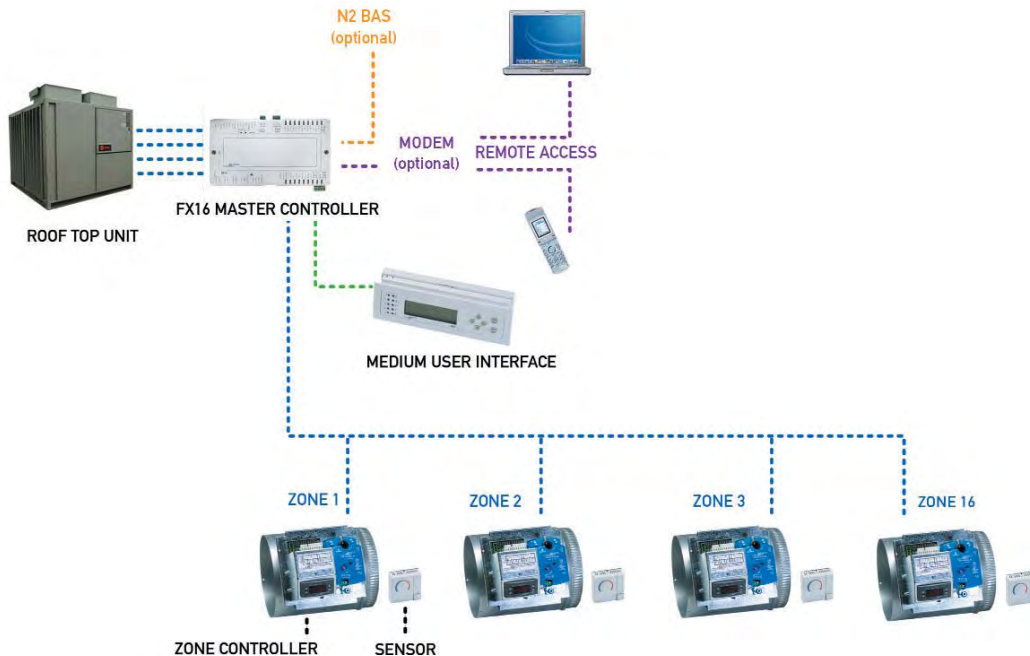

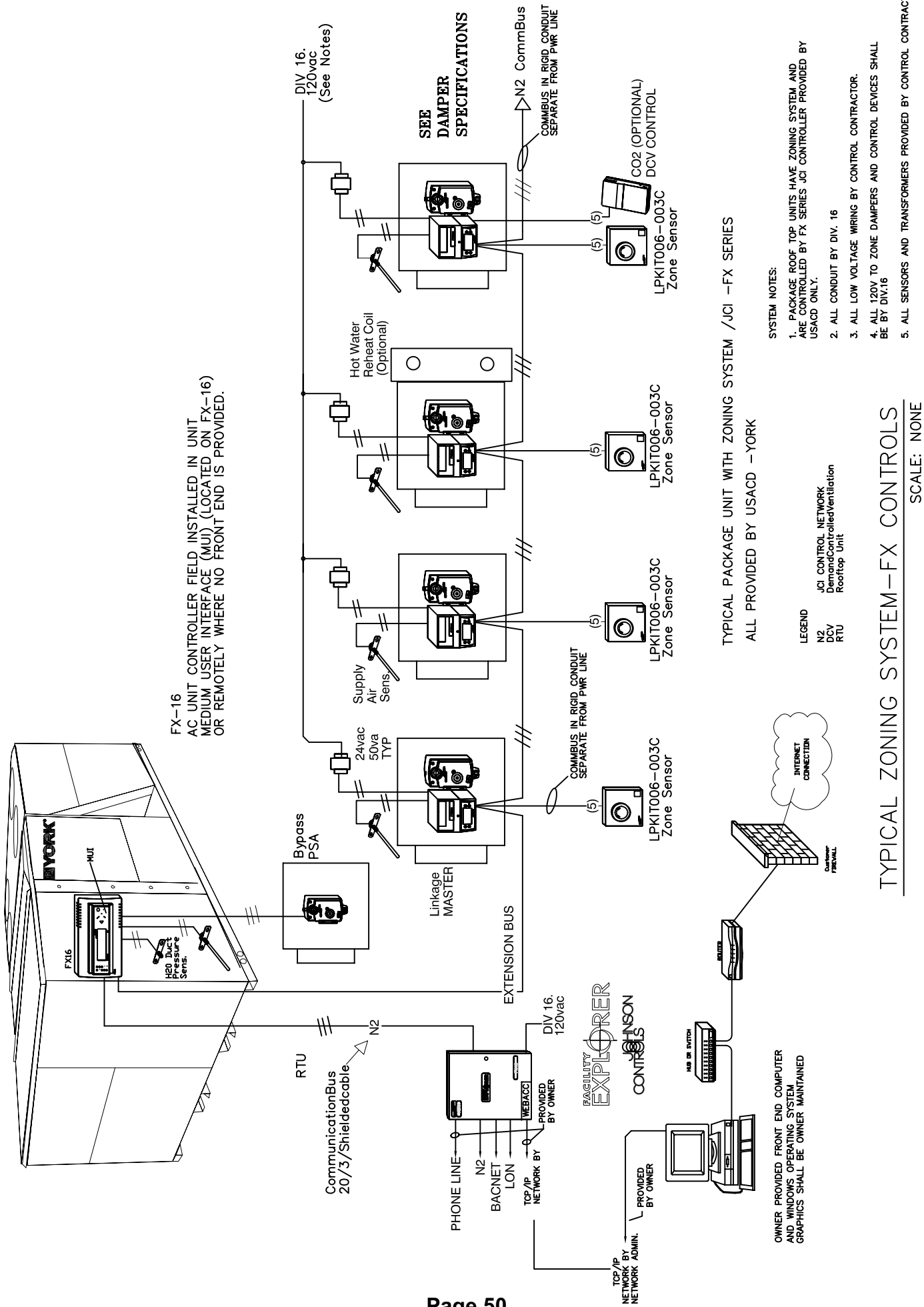

FX-16
AC UNIT CONTROLLER FIELD INSTALLED IN UNIT
MEDIUM USER INTERFACE (MUI) (LOCATED ON FX-16)
OR REMOTELY WHERE NO FRONT END IS PROVIDED.

- SYSTEM NOTES:**
1. PACKAGE ROOF TOP UNITS HAVE ZONING SYSTEM AND ARE CONTROLLED BY FX SERIES JCI CONTROLLER PROVIDED BY USACD ONLY.
 2. ALL CONDUIT BY DIV. 16
 3. ALL LOW VOLTAGE WIRING BY CONTROL CONTRACTOR.
 4. ALL 120V TO ZONE DAMPERS AND CONTROL DEVICES SHALL BE BY DIV.16
 5. ALL SENSORS AND TRANSFORMERS PROVIDED BY CONTROL CONTRACTOR.

TYPICAL ZONING SYSTEM-FX CONTROLS
SCALE: NONE

TSS – Single Duct Variable Air Volume Terminal



- An integrated VAV box with direct digital controls eliminates the coordination and difficulties associated with factory mounting
- Downloading of software, setting of parameters, addressing and testing at the factory reduces startup time and lowers risk
- Superior flow measuring provides for lower minimum cubic feet per minute (CFM) values, which reduces energy costs and noise while maintaining comforts in the zone
- Installation time can be reduced with the low profile compact design and standard metal hanging straps
- Units wired in compliance with all applicable National Electrical Code (NEC) requirements and tested in accordance with Air Conditioning and Refrigeration Institute (ARI) standard 880
- Offers damper stall detection, starved box detection, actuator motor duty cycle, VAV box flow test, and other diagnostics on most models (VMA Series)

TSS Terminals provide Variable Air Volume (VAV) control beyond the typical single duct box. They are specifically designed for precise air delivery throughout the entire operating range, regardless of the installed inlet conditions. These units can be ordered with or without a Direct Digital Controller (DDC), which can operate as a stand-alone unit, on a Johnson Controls N2 trunk, or on a LON® trunk.

TSS Terminals take advantage of typical benefits provided by single duct units, while performing at extremely low sound levels. This is critical in today's buildings where occupants are placing more emphasis on indoor acoustics. The TSS Terminal is manufactured and assembled with a multi-point, center-averaging airflow sensor, which provides a signal to the controller enabling it to quietly and precisely measure airflow.

Bundled with the TSS Terminal is a digital controller from the VAV Modular Assembly (VMA) Series or the LN Series. Each model in the VMA1400 Series and the LN Series combines a controller, pressure sensor, and actuator housed in one pre-assembled unit.

Standard Features

Construction

- ARI 880 certified and labeled
- 22-gauge galvanized steel casing and valve
- G90 galvanized steel
- 1/2", 4lb/ft³ skin, dual density fiberglass insulation, glued and clinch-pinned in place

Hot Water Coils

- ARI 410 certified and labeled
- 1-, 2-, 3-, 4-row coils
- Tested at a minimum of 350 psig under water
- Mechanically expanded copper tubes leak tested to 350 psig air pressure
- Male sweat type water connections

Primary Air Valve

- Embossed rigidity rings
- Low-thermal conducting damper shaft with position indicator
- Mechanical stops for open and closed position
- Multi-point center-averaging airflow sensor
- Brass balancing tees
- Plenum-rated sensor tubing

Electrical Components

- cETL listed for safety compliance
- National Electrical Manufacturers Association (NEMA) Type 1 wiring enclosure

Electric Heat

- ETL listed as an assembly for safety compliance
- Integral electric heat assembly
- Automatic reset primary and back-up secondary thermal limits
- Single-point power connection
- Hinged electrical enclosure
- Fusing per NEC
- Airflow switch
- Ni-chrome elements
- Primary/Secondary power terminations
- Wiring diagram

Optional Features

Construction

- 20-gauge galvanized steel construction
- 3/4" or 1" fiberglass insulation
- Scrim-reinforced, foil-faced insulation meeting American Society for Testing and Materials (ASTM) C1136 for mold, mildew, and humidity resistance
- 1/2" Elastomeric closed-cell foam insulation
- Double wall construction with 22-gauge liner
- Mounting brackets to accept all-thread hanging rods or wire hangers
- Low temperature construction for use in thermal storage applications, including a thermally isolated primary air inlet and a composite damper shaft

Hot Water Coils

- Low pressure steam coils
- Multi-circuit coils for reduced water pressure drop
- Opposite hand water connections
- Bottom and top access plates for cleaning

Electrical Components

- Full unit toggle disconnect and inline motor fusing
- Primary and secondary transformer fusing

Electric Heat

- Proportional solid state relay (SSR) heater control
- Mercury contactors
- Door interlocking disconnect switches
- Disconnect (toggle or door interlocking)
- Pneumatic Electric (PE) switches
- Mercury and magnetic contactors
- Manual reset secondary limit
- 24 volt control transformer
- Special watt densities
- Finned tubular elements

Controls

- Factory-provided controls
- Direct digital controls (DDC) for N2 or LON® networks
- Pneumatic controls

TSL – Single Duct Low Height Variable Air Volume Terminal



- An integrated VAV box with direct digital controls eliminates the coordination and difficulties associated with factory mounting
- Downloading of software, setting of parameters, addressing and testing at the factory reduces startup time and lowers risk
- Superior flow measuring provides for lower minimum cubic feet per minute (CFM) values, which reduces energy costs and noise while maintaining comforts in the zone
- Installation time can be reduced with the low profile compact design and standard metal hanging straps
- Units wired in compliance with all applicable National Electrical Code (NEC) requirements and tested in accordance with Air Conditioning and Refrigeration Institute (ARI) standard 880

TSL Terminals provide variable air volume (VAV) control beyond the typical single duct box. They are specifically designed for precise air delivery throughout the entire operating range and are only 10" in height, making them ideal for shallow or congested ceiling plenum applications. These units can be ordered with or without a Direct Digital Controller (DDC), which can operate as a stand-alone unit, on a Johnson Controls N2 trunk, or on a LON® trunk.

TSL Terminals take advantage of typical benefits provided by single duct units, while performing at extremely low sound levels. This is critical in today's buildings where occupants are placing more emphasis on indoor acoustics. The TSS Terminal is manufactured and assembled with a multi-point, center-averaging airflow sensor, which provides a signal to the controller enabling it to quietly and precisely measure airflow.

Bundled with the TSL Terminal is a digital controller from the VAV Modular Assembly (VMA) Series or the LN Series. Each model in the VMA1400 Series and the LN Series combines a controller, pressure sensor, and actuator housed in one pre-assembled unit.

Standard Features

Construction

- ARI 880 certified and labeled
- 20-gauge, galvanized steel casing and valve
- G90 galvanized steel construction
- 1/2", 4 lb/ft³ skin, dual density fiberglass insulation glued and clinch pinned
- Invertible unit facilitates control installation on the left- or right-hand side

Hot Water Coils

- ARI 410 certified and labeled
- 1-, 2-, 3-, 4-row coils
- Left- or right-hand connections
- Tested at a minimum of 450 psig under water and rated at 300 psig working pressure at 200°F
- Aluminum fin construction with die-formed spacer collars for uniform spacing
- Mechanically expanded copper tubes leak tested to 450 psig air pressure and rated at 300 psig working pressure at 200°F
- Male sweat type water connections

Primary Air Valve

- 18-gauge, G90 galvanized steel construction
- Low thermal conductance damper shaft
- Position indicator on external end of damper shaft
- Mechanical stops for open and closed position
- Multi-point center-averaging airflow sensor
- Brass balancing tees
- Plenum-rated sensor tubing

Electrical Components

- cETL listed for safety compliance with Underwriters Laboratories Inc.® (UL) 1995
- National Electrical Manufacturers Association (NEMA) Type 1 wiring enclosure

Electric Heat

- Invertible unit facilitates control installation on the left- or right-hand side (not applicable if equipped with a mercury contactor)
- cETL listed as an assembly for safety compliance
- Automatic reset primary and back-up secondary thermal limits
- Primary auto-reset high limit

- Secondary high limit
- Airflow switch
- Single-point power connection
- Hinged electrical enclosure door
- Fusing per NEC

Optional Features

Construction

- Scrim-reinforced, foil-faced insulation meeting American Society for Testing and Materials (ASTM) C1136 for mold, mildew, and humidity resistance
- 1/2" Elastomeric closed-cell foam insulation
- Double wall construction with a 22-gauge liner
- Mounting brackets to accept all thread hanging rods or wire hangers
- Discharge sound attenuator (Model TSL-SA)

Hot Water Coil

- Coil access plate for cleaning coil
- Coil circuiting options for reduced water pressure drop
- Right- or left-hand water connections
- Bottom and top access plates for cleaning
- Steam coils

Electrical Components

- Toggle disconnect switch
- Primary and secondary transformer fusing

Electric Heat

- Proportional solid state relay (SSR) heater control
- Mercury contactors (if equipped with a mercury contactor, the unit cannot be inverted)
- Door interlocking disconnect switches
- Disconnect (toggle or door interlocking)
- Pneumatic Electric (PE) switches
- Mercury and magnetic contactors
- Manual reset secondary limit

Controls

- Factory-provided controls
- Direct Digital Controls (DDC), for N2 or LON® networks
- Pneumatic controls

Single Duct Variable Air Volume Terminal (Model TSS)

Unit Size	CFM	Bypass CFM	Weight	Dimensions				
				W x H x L	A	I	X	Y
6	200	300	18	10" x 10" x 11"	6 1/2"	5 7/8"	8 3/4"	8 3/4"
8	400	600	20	12" x 10" x 11"	6 1/2"	7 7/8"	10 3/4"	8 3/4"
10	600	900	25	14" x 12.5" x 13"	6 1/2"	9 7/8"	12 3/4"	11 1/4"
12	800	1200	30	16" x 15" x 13"	6 1/2"	11 7/8"	14 3/4"	13 3/4"
14	1100	1800	38	20" x 17.5" x 17.5"	6 1/2"	13 7/8"	18 3/4"	16 1/4"
16	1500	2200	42	24" x 17.5" x 17.5"	6 1/2"	15 7/8"	22 3/4"	16 1/4"
22	3000	5400	72	34" x 17.5" x 11"	8"	32 1/4" x 15 7/8"	32 3/4"	16 1/4"

Note: All dimensions are in inches with a tolerance of +1/8". Size 22 has a rectangular inlet collar. CFM based on 1000 FPM (Bypass 1500 FPM) for low to medium pressure applications.

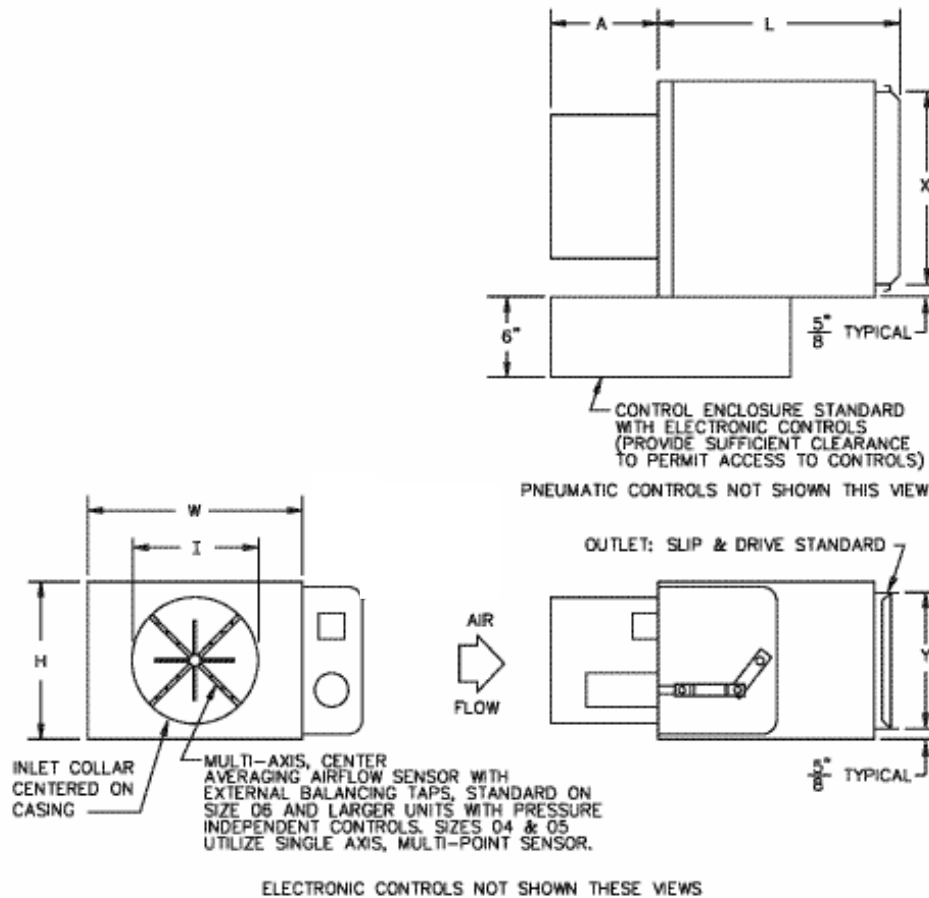

Clearance 24"

Dimensions – Model TSS

Single Duct Variable Air Volume Terminal - Rectangular (Model TSL)

Unit Size	CFM	Bypass CFM	Dimensions				Weight
			A	W	L	X	
10	600	1200	10"	15"	12 1/2"	13 3/4"	26
12	800	1600	14"	19"	12 1/2"	17 3/4"	28
14	1200	2200	20"	25"	16 1/2"	23 3/4"	39
16	1500	3000	26"	31"	16 1/2"	29 3/4"	45

Notes: 1. For dimensional data for unit sizes 6 and 8, refer to the Single Duct Variable Air Volume Terminal (Model TSS). All dimensions are in inches with a tolerance of +1/8". Weights are in pounds. Weights are for the basic unit with the indicated option and control enclosure. Actual weight varies based on project-specific requirements for unit options, appurtenances, and controls. 2. Control enclosure is standard with factory-mounted electronic controls. 3. Check all national and local codes for required clearances.

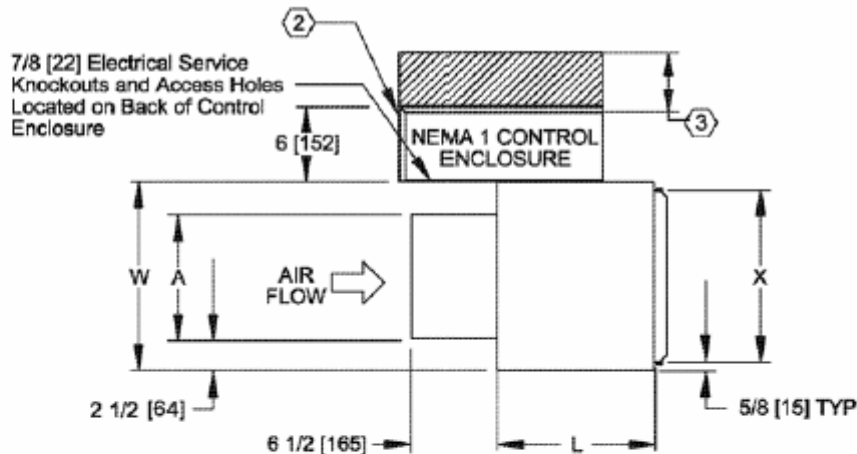

Top View

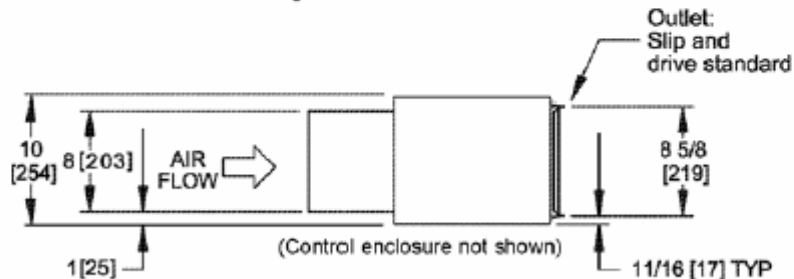

Side View

Dimensions – Model TSL

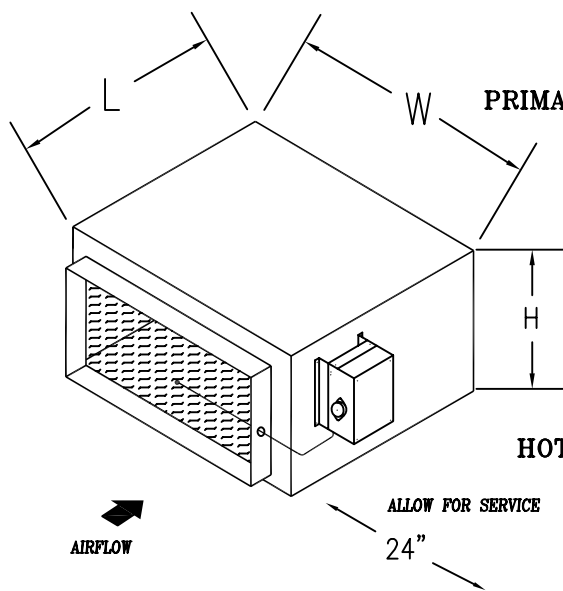

CASING: Minimum 22 gauge galvanized steel reinforced for maximum rigidity and minimum leakage. Units complete with a minimum of 1 inch to 1 1/2 inch density insulation in accordance with NFPR-90

PRIMARY AIR VALVE: Constructed of welded steel channel frame with 18 gauge galvanized steel blades, die formed stiffeners are full blade stop. Stainless steel side seals standard along with blade seals to minimize leakage. All hardware is zinc plated with brass pivot points and bronze oilite bearings.

ACTUATOR: Electronic, manufactured by JCI (FX SERIES),

HOT WATER COIL: Add 4 1/2 inches to airway length for 1 or 2 rows, 1/2 inch SW connection.

NOTES: 1. Dampers may be mounted in any position.
2. Bypass dampers are sized for 100% bypass relief. (see bypass damper selection chart)

35PSA ZONE/BYPASS DAMPER							
MODEL NUMBER	ZONE CFM	BYPASS CFM	INLET + 1/4"	H	W	L	(lbs)
PSA-06-006	600	1000	10 X 9	12	11	13	17
PSA-08-010	1000	2000	16 X 10	12	18	13	23
PSA-10-016	1000	2000	16 X 10	12	18	13	23
PSA-12-022	1500	2500	16 X 10	12	18	13	23
PSA-14-028	2000	4000	29 X 10	12	31	13	38
PSA-16-035	2000	4000	29 X 10	12	31	13	38
PSA-18-050	3000	6000	26 X 16	18	28	22	45
PSA-20-065	4000	8000	32 X 16	18	34	22	51
PSA-24-100	5000	10000	40 X 16	18	42	22	63

*ZONE CFM BASED ON 1000 FPM

*BYPASS CFM BASED ON 2000 FPM

SIZE TO 100% OF UNIT AIRFLOW (MANF. RECOMMENDED)

*PROVIDED BY USACD-YORK

ADDITIONAL DAMPER
SPECIFICATIONS – 35PSA (RECTANGULAR)

SCALE: NONE

STERIL-AIRE®

UVC for HVAC™

Model SEN Series UVC Emitters™

Single-Ended, NEMA 4X
Very High Output Germicidal
Light Source for Outdoor A/C Units

needed to maintain microbial control. The UVC Emitter, by contrast, has a 12-month service life – and even after a full year, it has 2-1/2 times greater output than competitive devices deliver on Day 1! As a result, only Steril-Aire can ensure the germicidal performance you need, with no return of microbial growth, for 3-4 times longer than the competition



Applications

Steril-Aire Single-Ended NEMA 4X (SEN Series) fixtures combine the externally mounted design of the SE Series with a weather resistant NEMA 4X fixture. Installed from the exterior of rooftop A/C units or ductwork, they are ideal for difficult to access outdoor sites. By creating two 1" holes in the equipment wall and mounting the fixture, the devices may be installed vertically or horizontally. Only the lamp or tube penetrates into the system, while the power supply remains external. Choose from six tube lengths (16", 20", 24", 30", 36" and 42") and four voltage options (115, 208, 230 or 277 Vac).

Benefits

- Kills or inactivates surface and airborne microorganisms that contribute to poor IAQ and/or the spread of infectious disease, including: mold and mold spores, bacteria (including *TB*, *Legionella*, *E. coli*, *Listeria*, *salmonella* and *whooping cough*); and viruses (including *colds*, *flu*, *measles*).
- Delivers an average of 5 times the output of competitive UVC products at HVAC operating temperatures, for 3-4 times longer life, while providing more reliable germicidal control.
- Uses patented state-of-the-art solid-state electronic power supply for enhanced reliability and performance.
- Continuously cleans coils, drain pans, plenums and ducts, eliminating costly cleaning programs and the use of harmful chemicals and disinfectants.
- Lowers HVAC energy costs by restoring heat transfer and net cooling capacity.
- Produces no ozone or other secondary contaminants – will not harm building occupants, equipment or furnishings.
- Offers lowest life-cycle cost of any UVC product. Return on investment is often less than one year.
- Installs quickly and easily, with no need to open equipment – ideal for packaged systems and/or ducts.

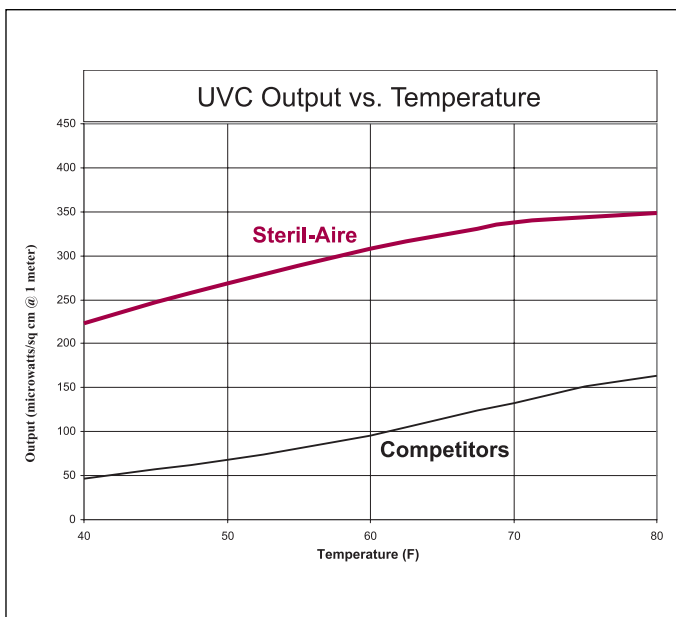

Steril-Aire's multi-patented UVC Emitter™ provides the best and longest-lasting UVC performance available. As shown in the comparison graph (*above*), it has been independently tested to deliver an average of 5 times the output of other ultraviolet devices under HVAC operating conditions (45° F @ 550 fpm air velocity).

Competitive UVC lights must be changed every 3-4 months because they quickly lose the output or "killing power"

Model SEN Specifications

The UVC Emitter™ and fixture shall be factory assembled and tested. They shall consist of a housing, power source, Emitter socket and Emitter.

The housing shall be constructed of 304 stainless steel and shall be powder coated to withstand the elements and HVAC environments. Housing shall be equipped with a bottom side electrical opening to facilitate wiring fixture to unit power. It shall incorporate all components into one integral assembly that maximizes integrity and serviceability. It shall be designed for mounting from outside the

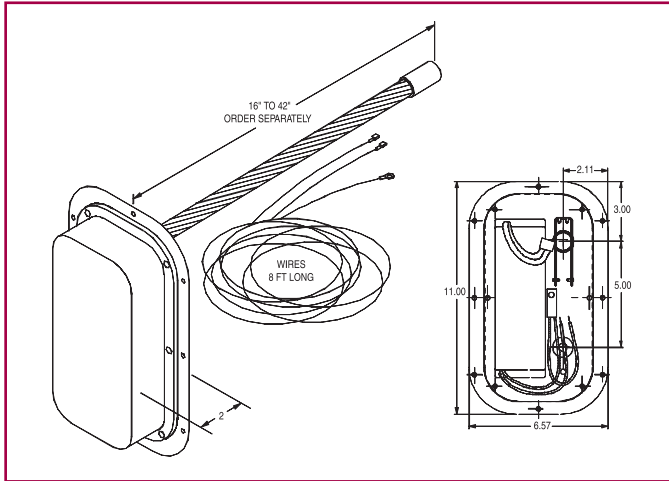

This product may be covered by one or more of the following patents, others pending: 5,334,347/ 5,866,076/ 5,817,276/ 6,372,186/ 6,313,470/ 6,245,293/ 6,267,924/ 6,280,686/ 6,423,882.

airstream with only the Emitter in the conditioned air. Emitter shall be held in place and supported in the airstream by a patented integral collar, o-ring and heavy-duty spring wire fastener. The patented tube mount section shall allow for quick and easy removal during lamp replacement. The housing shall include an on-off switch.

The power source shall be a Class P2, electronic rapid start type with a power factor of >0.95 and a power conversion of >75%. It shall be available in 115-208/230 and 277 Vac, 50/60 Hertz, and single phase. It shall be designed to maximize photon production, irradiance and reliability in cold or moving airstreams of 35-170° F, 100% RH and at up to 2000 fpm velocity. The design shall include RF and EMI suppression.

The socket shall be a Circline® 4 pin type with sufficient wire length to facilitate service.

The Emitter shall be a very high output, hot cathode, T5 diameter, Circline® cell-base type that produces a UVC band of 250-260 nm. Each tube shall be capable of producing the specified output at up to 2000 fpm velocity and temperatures of 35-170° F. It shall produce no ozone or other secondary contaminants.

Independent testing: The unit shall be tested by an independent test laboratory in accordance with the general provisions of IES Lighting Handbook, 1981 Applications Volume, and shall be verified through independent testing to provide output per 1" arc length of not less than 10 µW/cm² at 1 meter in a 400 fpm airstream of 45° F.

Unit shall comply with UL Standard 1995 for use in HVAC equipment and carry the "UL" and "ULC" labels.

Ordering Information

Model No.	Part No.	Description	Length	Electrical	Weight
SEN 1 VO	12001900	Single-Ended Fixture	N/A	115, 208, 230V: 70-85 watts	3.3 lb.
SEN 1 VO	12002100	Single-Ended Fixture	N/A	277V: 70-85 watts	3.3 lb.
GTS 16 VO	21000100	UVC Emitter	16"	N/A	0.15 lb.
GTS 20 VO	21000200	UVC Emitter	20"	N/A	0.15 lb.
GTS 24 VO	21000300	UVC Emitter	24"	N/A	0.20 lb.
GTS 30 VO	21000400	UVC Emitter	30"	N/A	0.20 lb.
GTS 36 VO	21000500	UVC Emitter	36"	N/A	0.25 lb.
GTS 42 VO	21000600	UVC Emitter	42"	N/A	0.25 lb.

STERIL-AIRE®

Steril-Aire, Inc.

Corporate Office:

2840 N. Lima Street
 Burbank, CA 91504
 Telephone: 818-565-1128
 Fax: 818-565-1129

Website: www.steril-aire.com
 Email: sales@steril-aire.com



Complies with current U.S. and Canadian UL Standards for use in HVAC equipment.

Represented By:

DATE: _____
SUBMITTED TO: _____
COMPANY: _____ US-AC
DRAWN BY: _____ MAC
JOB NAME: _____
WEIGHT: _____
NOTES: _____

MANUAL 0-25%, OUTSIDE AIR INTAKE

YORK BHZ, BHX, DNY, DNZ, DEM 024-060, DNX 024-048
BHA, BHP, DEB, BHY, DEH, DNA, DNH 018-060

PART NUMBER:
0743 SERIES
0744 SERIES

MICROMETL PRODUCT NUMBER	X"	Y"	WEIGHT (LB.)
0743DNZ24600A	14 15/16	14 15/16	9 LBS

FEATURES

- * INSULATED PANEL (FOIL FACED)
- * GASKET AND HARDWARE PACKAGE
- * PREPAINT GALVANIZED STEEL CONSTRUCTION
- * PREPUNCHED MATING HOLES

USE **0744DNZ24600AMTR**
FOR 2 POSITION MOTORIZED
OUTSIDE AIR HOOD

DOWNSHOT
APPLICATION

HORIZONTAL
APPLICATION

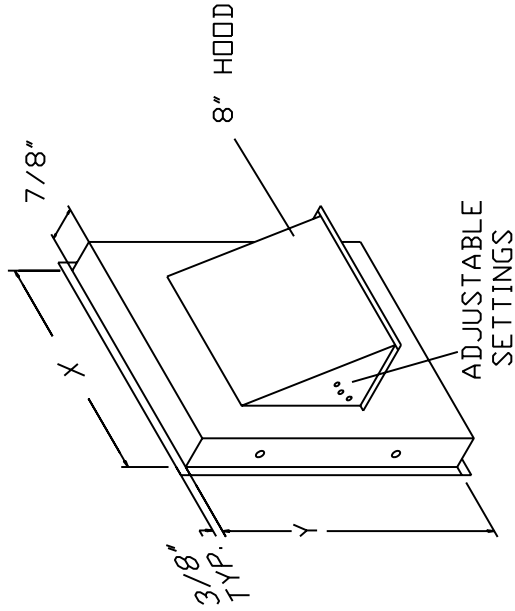

SUBMITTAL

W557 SERIES

<http://www.rezine.net>

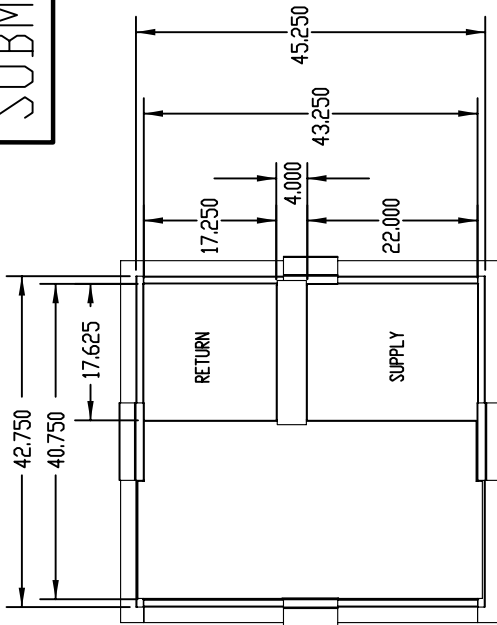
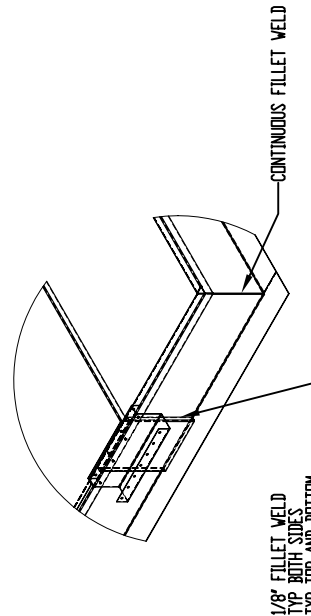
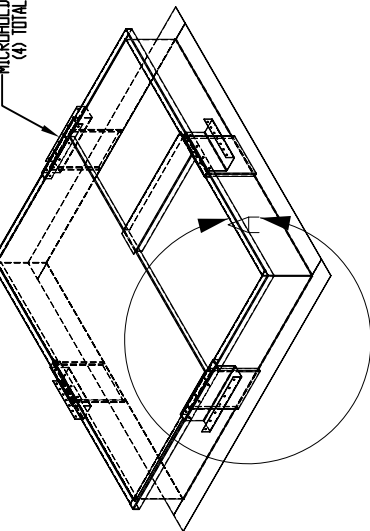

- * WELDED CONSTRUCTION
- * PERIMETER WOOD MAILER
- * GASKET PACKAGE
- * FACTORY INSTALLED HOLDDOWNS
- * INSULATED DECK PAN

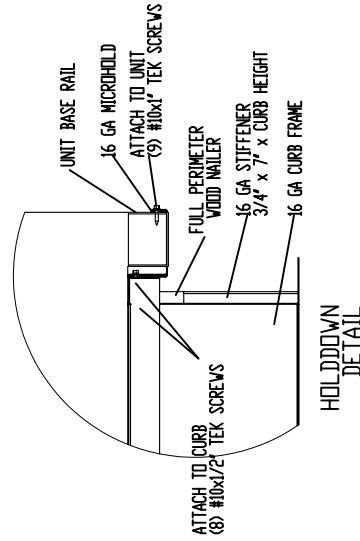
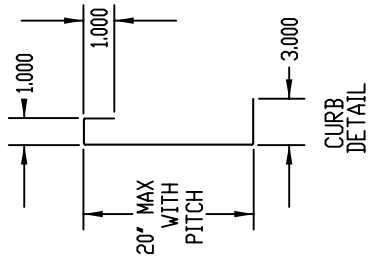

Micromet Corporation

PRODUCT NUMBER:
W557 SERIES
WELDED CURBS

W557-C014-01CBC 14' TALL

Sparks, NV. (800) 884-4662
Indianapolis, IN. (800) 662-4822
Longview, TX. (903) 248-4800

STRUCTURALLY CALCULATED WELDED
CURB FOR YORK DNX, BHX 024-060

DATE:	07/2007
DRAWN BY:	MAC
WEIGHT:	65/85/115
MEETS SEISMIC REQUIREMENTS FOR FOLLOWING CODES:	
2001 CBC	
2006 IBC	

THE INFORMATION CONTAINED IN THIS DRAWING IS THE SOLE PROPERTY OF MICROMET CORPORATION. ANY REPRODUCTION IN PART OR WHOLE WITHOUT THE WRITTEN PERMISSION OF MICROMET CORPORATION IS PROHIBITED.

SUBMITTAL

0403-572A SERIES

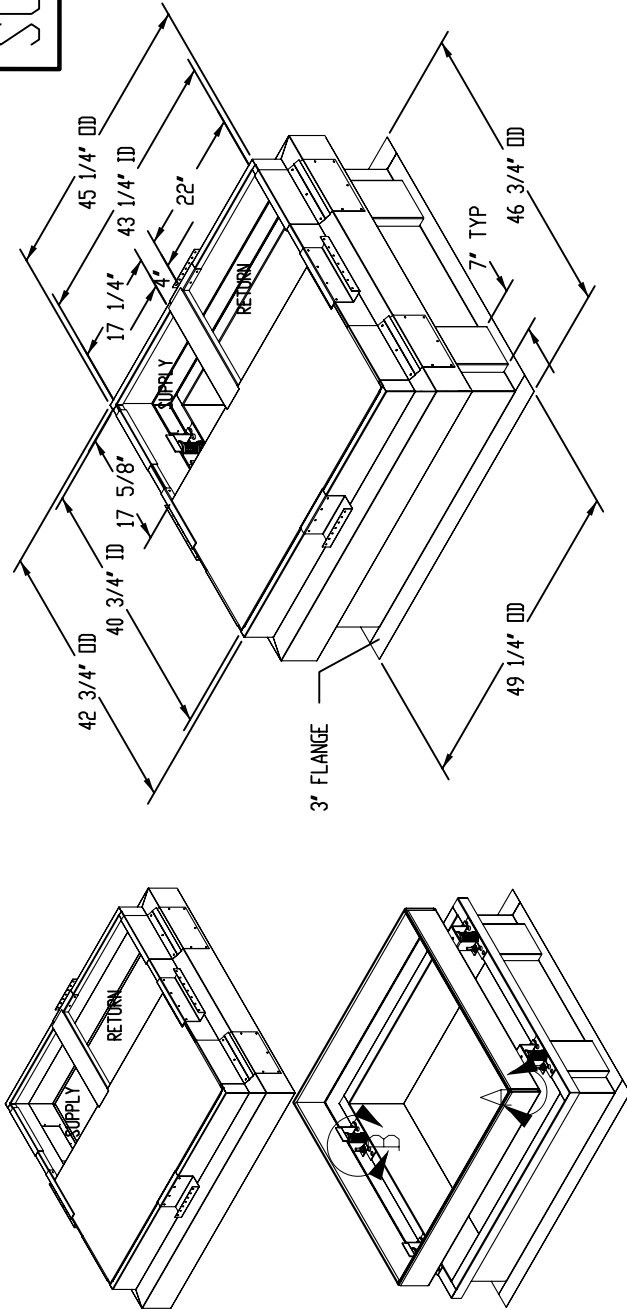

- * WELDED CONSTRUCTION
- * PERIMETER WOOD NAILER
- * GASKET PACKAGE
- * FACTORY INSTALLED HOLDDOWNS
- * OSHPD PRE-APPROVED 2" DEF
- * SEISMIC RESTRAINTS (DPA#0070)

<http://www.rezine.net>

DETAIL A
SCALE 1 : 12

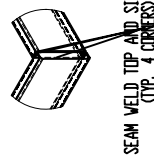

10 GA SUPPORT
ASSY DETAILS

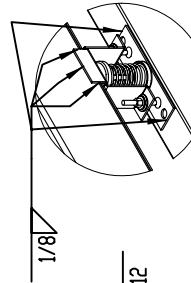

DETAIL B
SCALE 1 : 8

ISOLATOR WELDING
STANDARD OFFERING

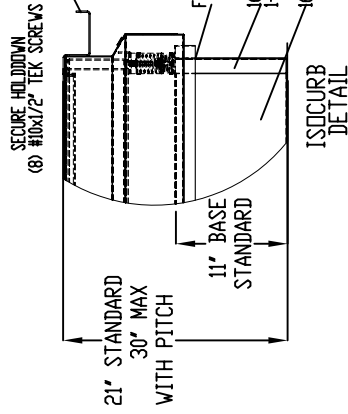

PRODUCT NUMBER:
0403-572A
ISOLATION CURBS

0403-572A-8B-01CBC 18' TALL
0403-572A-01CBC 21' TALL

Micrometl Corporation

STRUCTURALLY CALCULATED VIBRATION ISOLATION

CURB FOR YORK DNX, BHX 024-060

Sparks, NV. (800) 884-4662
Indianapolis, IN. (800) 662-4822
Longview, TX. (903) 248-4800

DATE:	07/2007
DRAWN BY:	MAC
WEIGHT:	260
MEETS SEISMIC REQUIREMENTS FOR FOLLOWING CODES:	
2001 CBC	
2006 IBC	

THE INFORMATION CONTAINED IN THIS DRAWING IS THE SOLE PROPERTY OF MICROMETL CORPORATION. ANY REPRODUCTION IN PART OR WHOLE WITHOUT THE WRITTEN PERMISSION OF MICROMETL CORPORATION IS PROHIBITED.