

SUBMITTAL

0403-652A SERIES

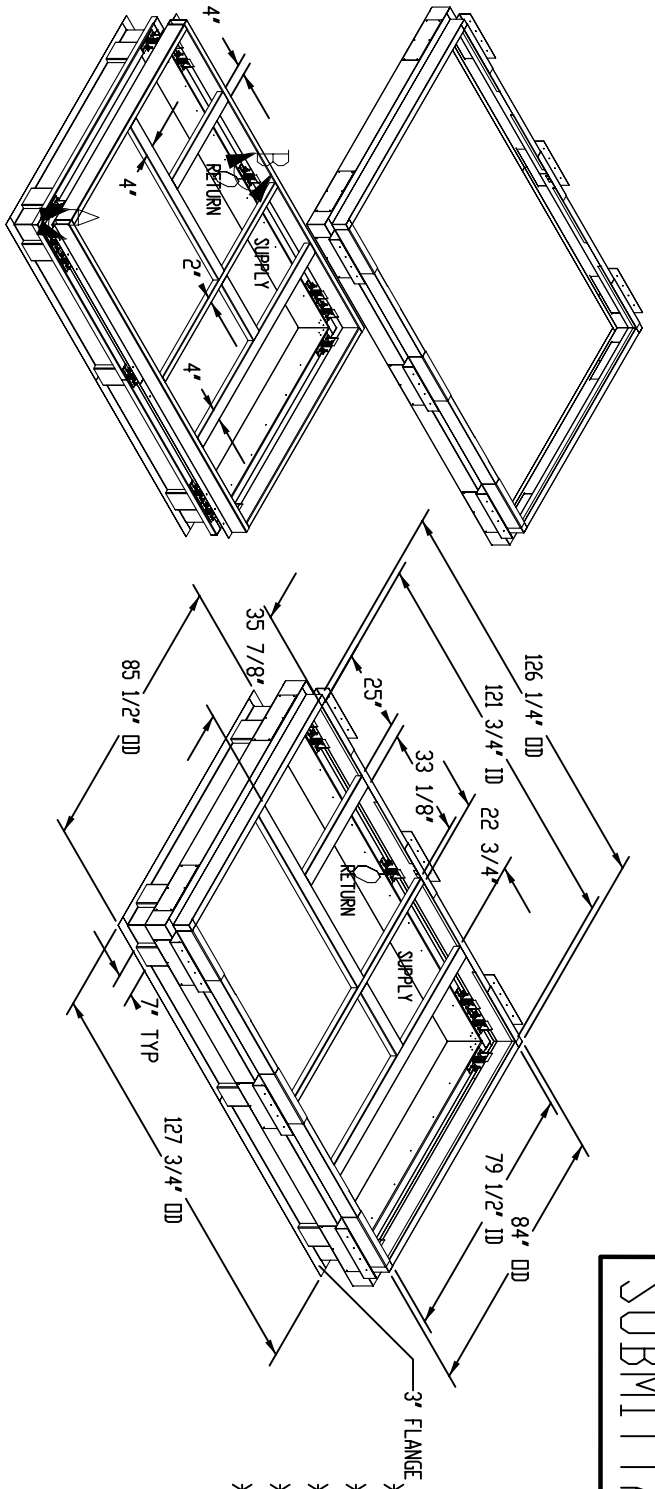

- * WELDED CONSTRUCTION
- * PERIMETER WOOD NAILER
- * GASKET PACKAGE
- * FACTORY INSTALLED HDL DDOWNS
- * DSHPD PRE-APPROVED 2" DEF
- * SEISMIC RESTRAINTS (DPA#0070)

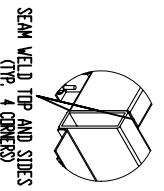

DETAIL A
SCALE 1 : 10
2X6 TUBE STEEL
SUPPORT ASSY DETAILS

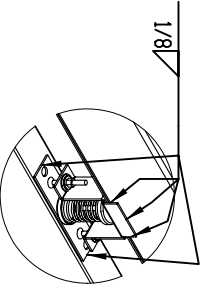

DETAIL B
SCALE 1 : 8

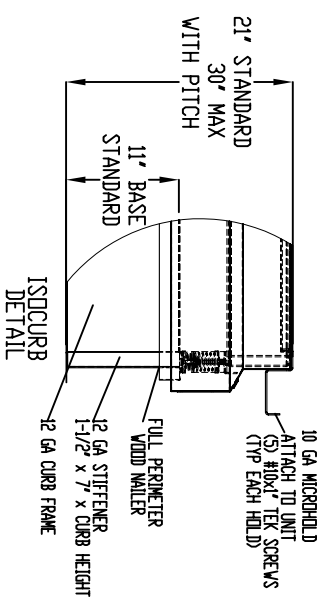

Micrometl Corporation

PRODUCT NUMBER:
0403-652A
ISOLATION CURBS

0403-652A-8B-01CBC
0403-652A-01CBC

18" TALL
21" TALL

Sparks, NV, (800) 884-4662
Indianapolis, IN, (800) 662-4822
Longview, TX, (903) 248-4800

STRUCTURALLY CALCULATED VIBRATION ISOLATION
CURB FOR YORK BP 240

DATE: 07/2007
DRAWN BY: MAC
WEIGHT: 1040/1100/1160
MEETS SEISMIC REQUIREMENTS FOR FOLLOWING CODES:
2001 CBC
2006 IBC

THE INFORMATION CONTAINED IN THIS DRAWING IS THE SOLE PROPERTY OF MICROMETL CORPORATION. ANY REPRODUCTION IN PART OR WHOLE WITHOUT THE WRITTEN PERMISSION OF MICROMETL CORPORATION IS PROHIBITED.