

SUBMITTAL

W565 SERIES

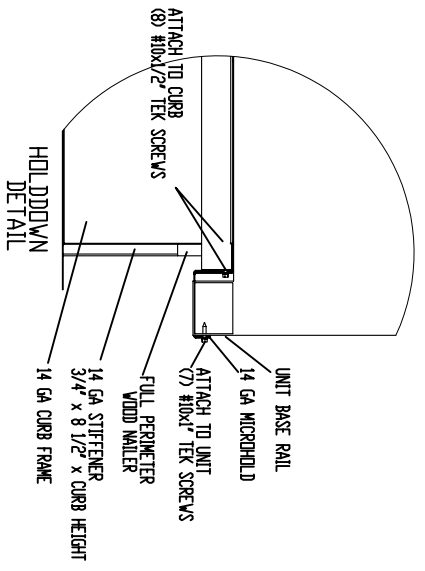
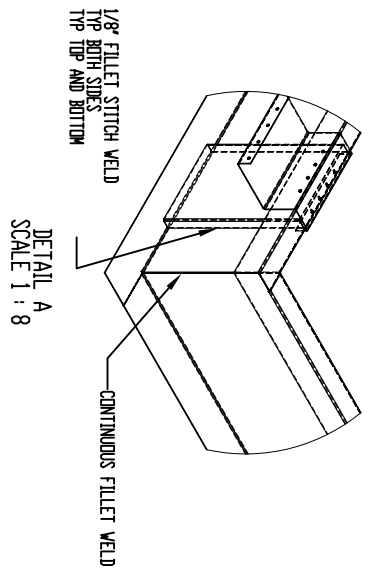
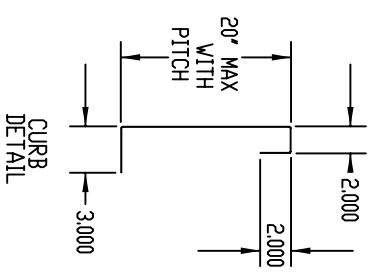
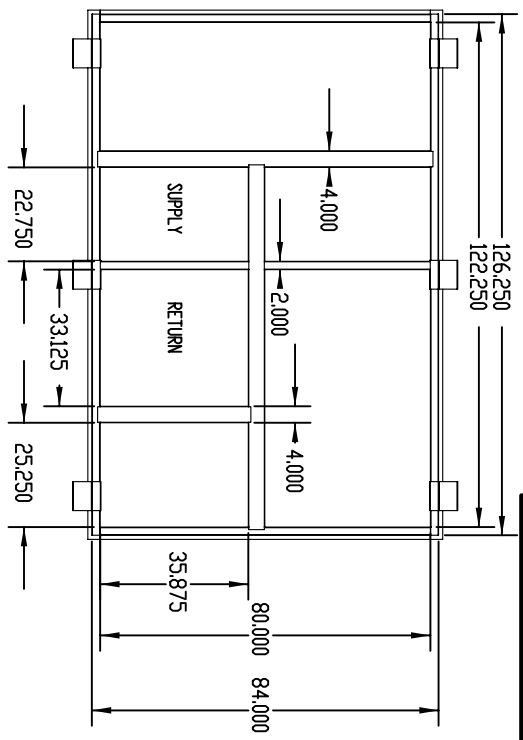
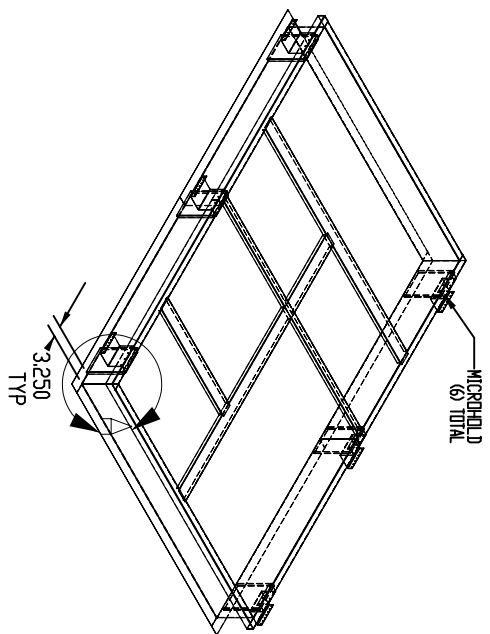

Micrometl Corporation

PRODUCT NUMBER:
**W565 SERIES
WELDED CURBS**

W565-C008-01CBC 8' TALL
W565-C011-01CBC 11' TALL
W565-C014-01CBC 14' TALL

STRUCTURALLY CALCULATED WELDED

BP 240

Sparks, NV. (800) 884-4662
Indianapolis, IN. (800) 662-4822
Longview, TX. (903) 248-4800

THE INFORMATION CONTAINED IN THIS DRAWING IS THE SOLE PROPERTY OF MICROMETL CORPORATION. ANY REPRODUCTION IN PART OR WHOLE WITHOUT THE WRITTEN PERMISSION OF MICROMETL CORPORATION IS PROHIBITED.

DATE:	07/2007
DRAWN BY:	MAC
WEIGHT:	250/286/310
MEETS SEISMIC REQUIREMENTS FOR FOLLOWING CODES:	
2001 CBC	
2006 IBC	